

SYNTHI-AKS

Circuit Diagrams
and Layouts

from

EMSA
11 North Main
P.O. Box 439
Williamsburg, MA
01096
(413) 268-3588

The pulses generated are used to compile various gating signals.

The signal is divided by 2 by E22 (8,9,11,12) and again by 2 by E22 (2,3,5,6), and then by 16 by E23. By gating these signals together, a set of waveforms shown below is produced.

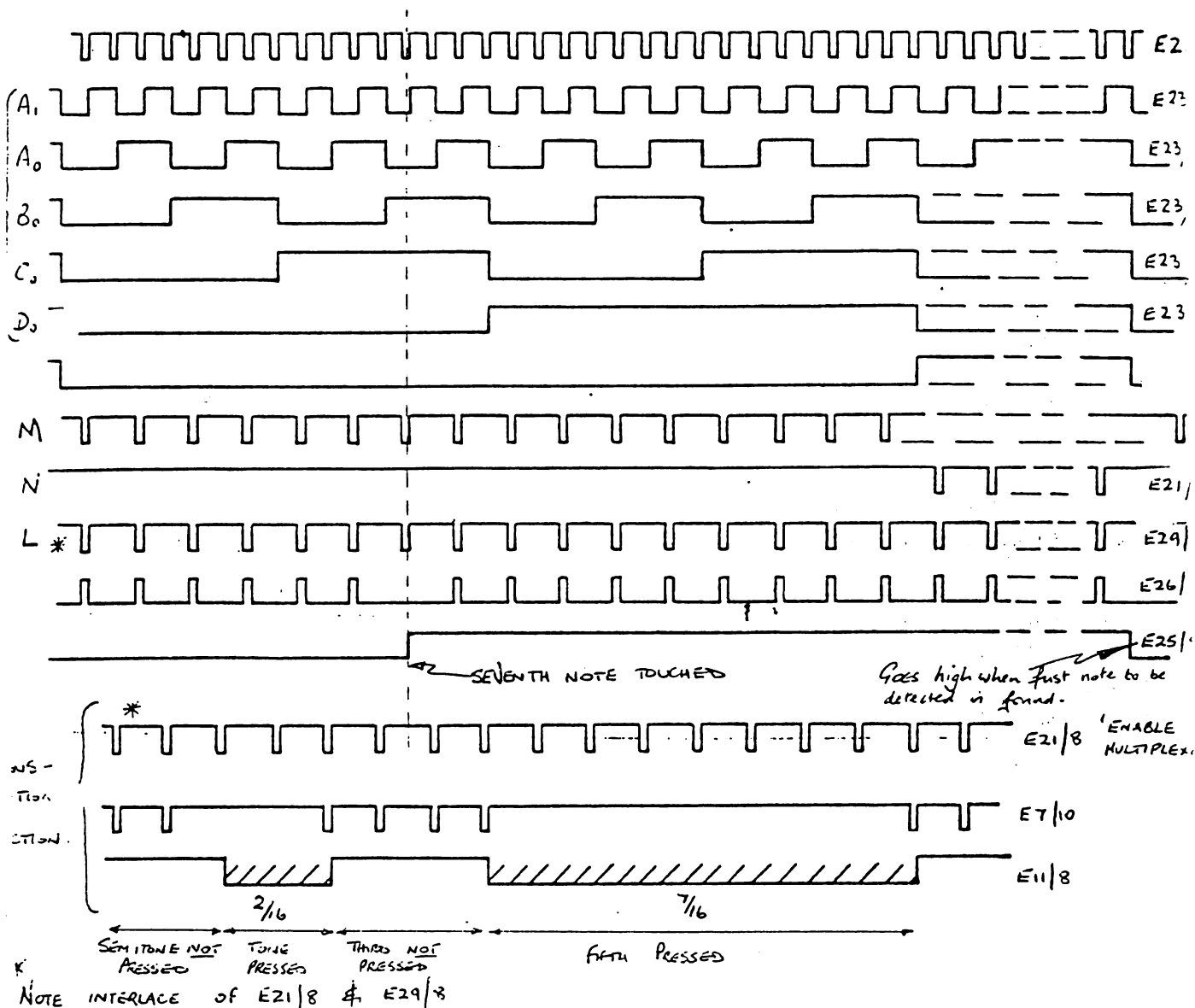

SIGNALS A1, A0, B0, C0 provide a four bit address code to the three data multiplexers. The top two multiplexers, E15, E27 are connected to the keyboard, and as only 30 notes are provided, then two inputs (E27 pins 7,8) are left permanently unconnected. The lower multiplexer is the "transposition pad" unit.

MULTIPLEXERS - an electronic 16 way switch; single pole.

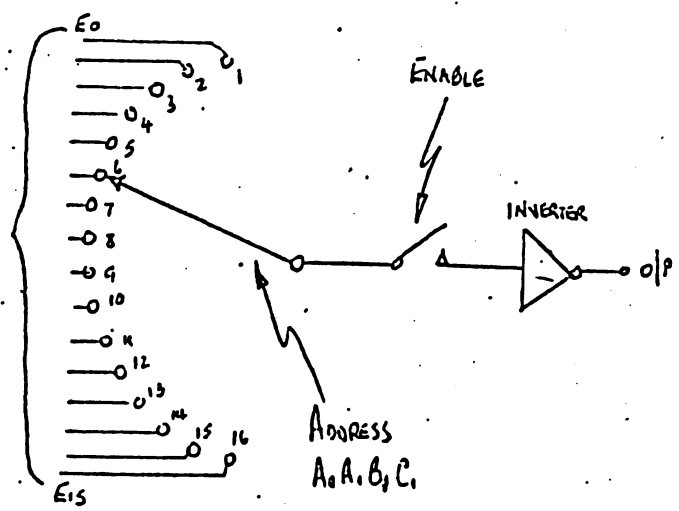
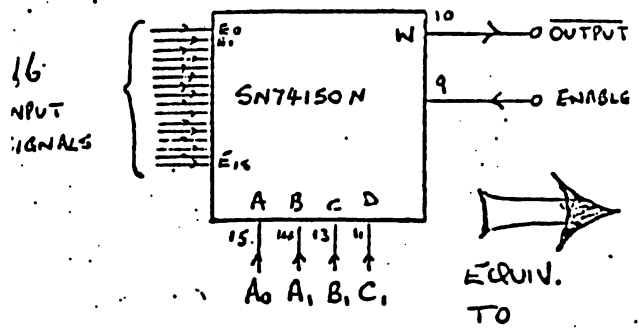

The 16 inputs; E0 to E15, can be considered as the 16 inputs to a rotary switch. The switch position (only one pole) is determined by the address code, ie A0, A1, B1, C1, labelled ABCD on the actual device.

Switch Position	(A) A0	(B) A1	(C) B1	(D) C1
E0	1	0	0	0
E1	2	1	0	0
E2	3	0	1	0
E3	4	1	1	0
E4	5	0	0	1
E5	6	1	0	1
E6	7	0	1	1
E7	8	1	1	1
E8	9	0	0	0
E9	10	1	0	0
E10	11	0	1	0
E11	12	1	1	0
E12	13	0	0	1
E13	14	1	0	1
E14	15	0	1	1
E15	16	1	1	1

Where 0 = low voltage)
 1 = high voltage) logic levels

← This is known as a truth table.

Thus, for an address

D C B A
 1 0 1 1 sorry about the reversed code

The switch is at position 12

A B C D
 1 1 0 1 ⇒ 12

'A' is known as the least significant bit - LSB

'D' is known as the most significant bit - MSB

The ENABLE SIGNAL acts as a switch; that is when this signal is high (1) the switch is open circuit, and the output (w) is permanently high.

When this signal is low (0) the switch is closed and so anyone of the 16 data inputs may be selected. The 'ENABLE' IS SOMETIMES called the STROBE.

Note that the output shows the inverted data. Thus to summarise.
 With a high (1) at data input 12, and address code of

A	B	C	D
1	1	0	1

 and an enable signal of logic 0, the output is (1) inverted, namely 0.

TOUCH SENSITIVITY.

The input to a TTL gate looks like:-

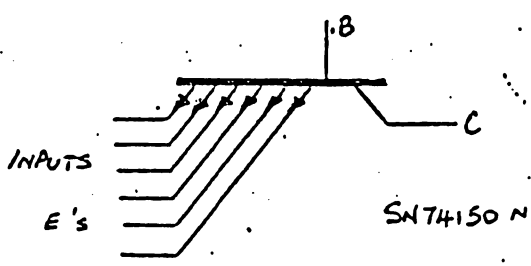

This is a multiple emitter, transistor, i.e. a transistor with, in this case, 6 emitters.

In the multiplexer, 4 of them are connected to the address code, one to the enable signal and the last to the touch plate.

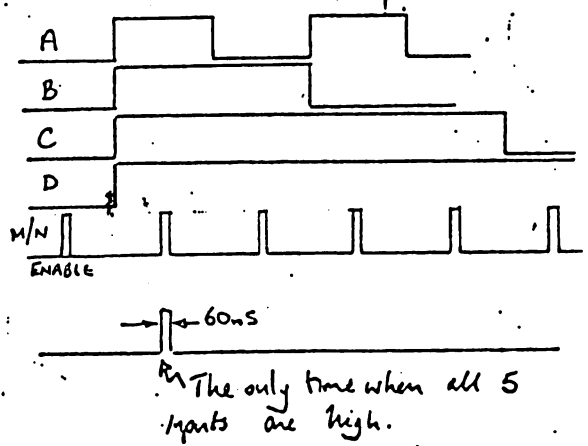
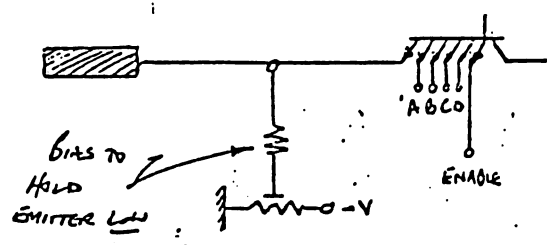

For each specific input there will only be one point in the Address cycle (32 bits) when all 5 emitters are high at the same time. When the bias is correctly aligned, the circuit will behave as follows:-

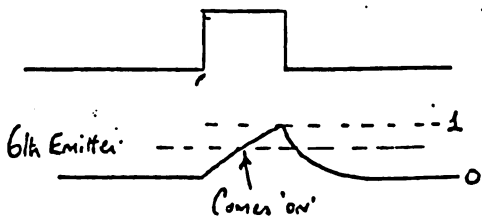

looking at the last trace we see that sixth emitter, which is connected to the touch plate, is dragged up, due to the associated capacitance of itself WRT its sister emitters. Infact, it is dragged

up so far that it changes state from a '0' to a '1'. BUT when a finger is placed on the associated touch plate, the capacitance of the finger increases the total capacitance as seen by the emitter, increasing it by as much as 10 to 100 pF, and this is sufficient

to prevent it from changing state. Thus, pressing the pad with a finger

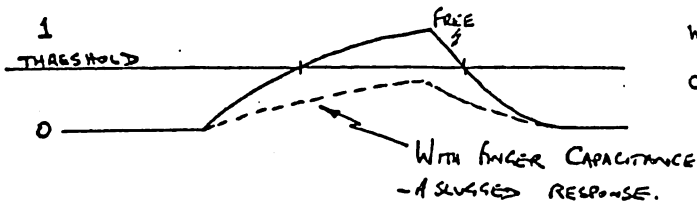

will prevent the data multiplexer output from changing state.

The enable signals 'M' and 'N' are



Thus one multiplexer is addressed, and then the other (i.e. E15 and 27) is then the other etc.

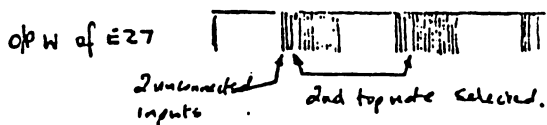

If more than one note is pressed, then several gaps in the outputs will be generated; however; the electronics that follow select the first note to appear, and as the keyboard is swept (addressed) from top to bottom, then the highest note of all the notes pressed is selected.

This piece of electronics is E26 (11,12,13) (4,5,6)
E25 (8,9,10,11,12,13), E16, E17, E18.

The two data outputs of MULTIPLEXERS E15, E17 are OR'ED together by E26 (11,12,13) (that is they are effectively just added together).

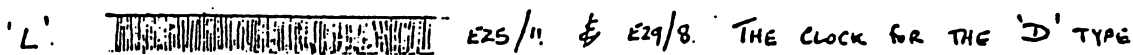

*WHEN looking for these waveforms, you much SYNC OFF of DO E23/11.

Now consider the 'D' type E 25 (8,9,10,11,12,13).

Assume that pin 8 is at logic 1. Therefore, Pin 5 E26 is at logic 1, and it is thus "enabled" in that it allows signals at its other pin (pin 4) to pass through it. The signal at pin 4 is the summed data output, which when it passes through the gate, is inverted. Notice that the clock pulses are coherent with the data signal.

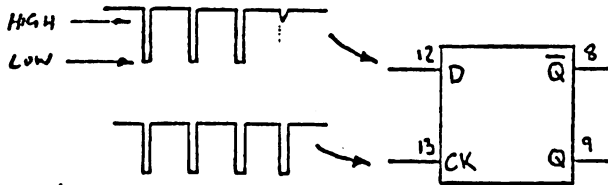

The D type operates as follows. It is an edge triggered device; that is data at its' D input is transferred to the Q output on the +ve transition of the clock. That is, put a 1 on

pin 12, clock the device and a 1 appears at pin 9, the Q output. SO, in the present example, when there are no notes pressed, the data is low when it is clocked, and so Q remains Low. But, when that data is high, then Q goes high, therefore Q (pin 8) goes low and in doing so inhibits E26 (4,5,6) the output of which thus remains high. The circuit has latched

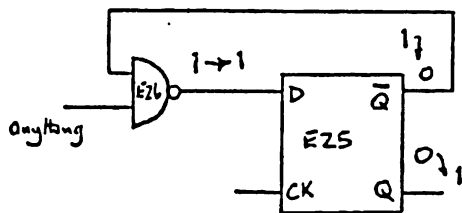

up, and it will remain latched up until it is released by a clearing pulse. Thus, E25, Q9 goes high and remains there when it detects the first note. (See page 2, waveforms). Now, E25, Q9 clocks the D types E16,17,18, which are fed with the address code (A, A₀, B₀, D₀). So, as soon as the first note is detected, its address is clocked into E16,17,18 which act as a one bit memory. At the end of one address

sweep (about 100μ sec.) the D type E25 is unlatched by a negative going pulse produced by differentiating the address bit D₀ (23 pin 11) with the CR network C4, R44.

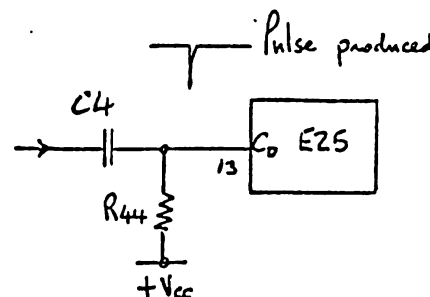
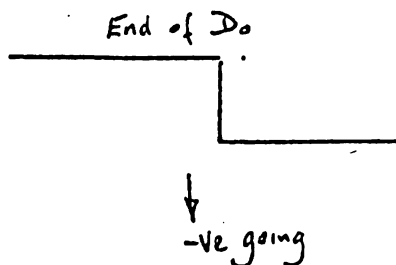

A LOW ON THE CLEAR INPUT OF A D TYPE CLEARS THE Q OUTPUT TO LOGIC 0

Thus, the D types E16, 17, 18 form a short term memory that is continually being updated (every 100 μ sec) as to highest key that is being selected. The output Pin 9 E25 is an excellent place to test the keyboard to see if the multiplexer for the KB and/or the address code is functioning.

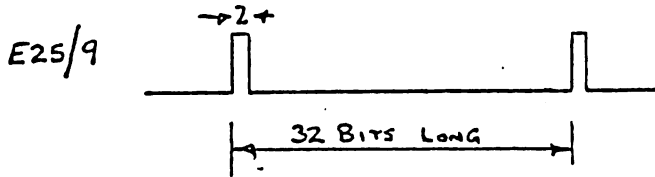

2ND BOTTOM NOTE PRESSED.

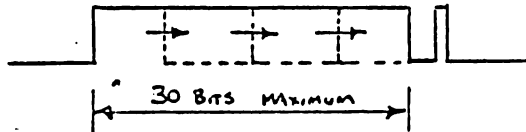

AS YOU SWEEP YOUR FINGER UP THE KEYBOARD THE WAVEFORM CHANGES AS SHOWN. (THE PULSE WIDTH ELONGATES)

RANDOM FUNCTION This is the same touch sensitive detector as for the KEYBOARD. However, as there is only one input, then no addressing is required. A slow clock pulse generator is used, (5KHz, 60n sec. pulses).

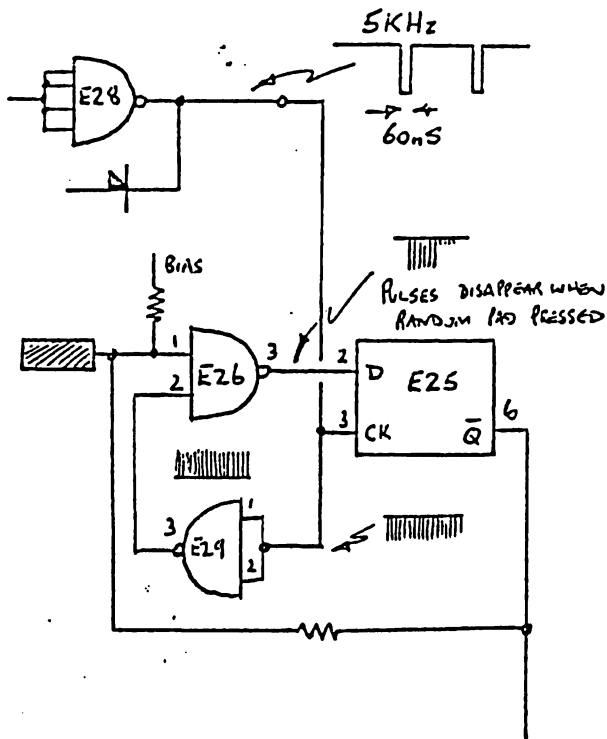

A separate oscillator, rather than the address oscillator is used, because:-

1. A long enough gap must be provided to allow the floating gate time to discharge.
2. If the address clock were to be used, the Random would not be random; this is because the network has a tendency to select the largest clock pulse and this means that particular notes occur more readily than others.

The operation is as follows. When a missing pulse is detected by E25 pin 2, the \bar{Q} output goes low and so the cct folds over. The \bar{Q} is connected to the set input of E25. This will cause the Q output to go high and in doing so it 'records' an address. (Any address in fact; it depends upon when the Random is pressed). When the random is released, the set input of E25 pin 10 returns to 1, and the circuit operates as before. As the Q output E25 pin 6 can go low at any point in time, then any note is selected, and hence the term 'random'. N.B. The random function can generate errors; this is a design error.

The errors can be generated by the random accidentally selecting address code Binary 11111 (i.e. 32). This is the 'Skip' code, and it will cause the meter to prematurely reset, and the memory to corrupt. To demonstrate this phenomenon, try this test; Set the Sequencer clock speed to about 3 to 4 on the knob, press record and then tap the random pad. There is a 32:1 chance of generating the skip code, and this will be detected by a premature reset of the meter.

DAC

The short term memory E16,17,18 feeds Q1 to 5 which form a DAC. (Digital to Analogue Converter) Slightly re-drawing the circuit, we the following;

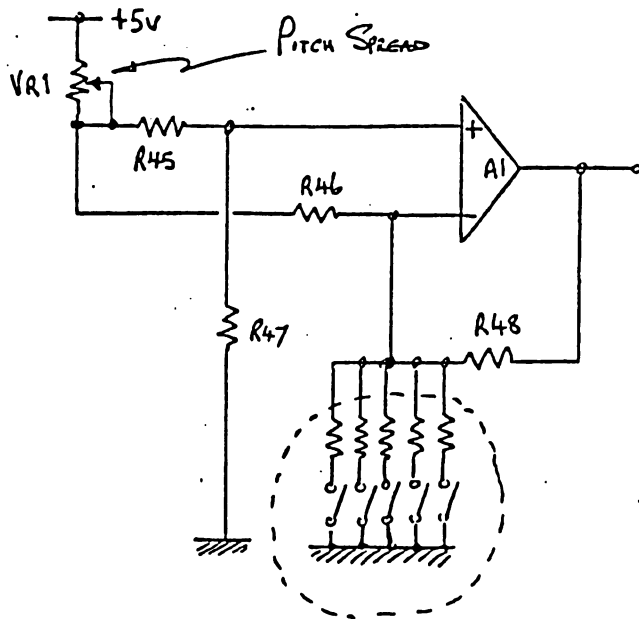

Inside the dotted box are 5 resistors and 5 switches. The resistors are R49 to R54, 1% m.o. resistors. The switches are Q1 to 5 and these are controlled by the stored address in E16, 17, 18.

When the address is 00000, all the switches are off, and so the circuit is just a simple differential amplifier, and the voltage at the output of A1 is 0V. When the switches turn 'ON', the output goes negative.

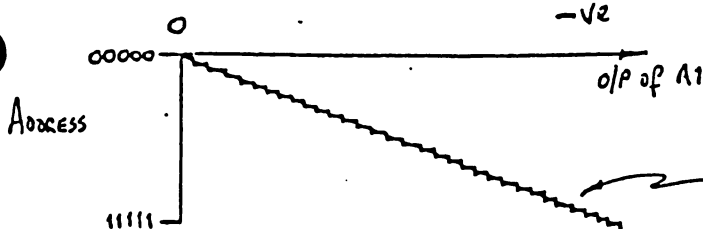

* NOTE WRT the short term memory E16,17,18. The lower half of E18 is different to the other 5 sections. This is the "key-pressed" section. It uses the clock line as its data input. This is because, when Q9, E25 is high, then a key is being pressed, and this is the data that it requires. It is clocked by \bar{D}_0 (known as $\bar{F} @ 8$, E26) at the end of an address sweep, and so its Q output (i.e. 9, E18) is high when a key is pressed and low when no key is pressed.

Note that the negative (1-0) transition of the \bar{Q} output (8, E18) is used to control the envelope trigger by turning transistor Q6 on when a key is pressed. The envelope trigger control pot is used to determine whether the trigger is generated from the real time or recorded output.

DYNAMIC RESPONSE The crystal gives the K.B. a dynamic function, but this is only employable in real time. That is, no information about the key pressure is recorded. The crystal produces a click when the K.B. is hit.

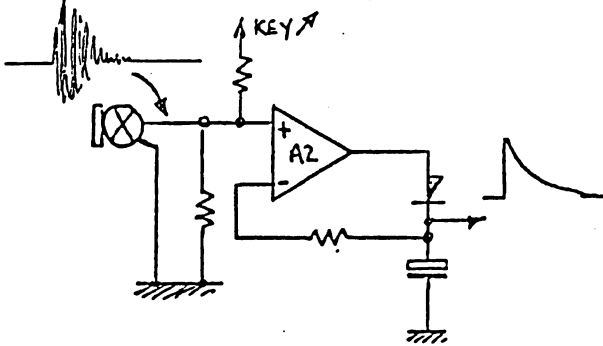

The network is a voltage follower with a diode in the feedback loop. The junction between the diode and the capacitor tries to follow the +ve voltage transient of the input and decays slowly (due to the storage of the capacitor) after the signal has

ceased. This voltage is used to control one of the output channels on a Synthi A.

RECORD, PLAY, CONTROL LOGIC * note RECORD AND PLAY are clocked from the random clock gen.

The RECORD and PLAY pads operate in the same way as the Random touch pad. However, the interconnection of E10 (1,2,3,4,5) with E10 (8,9,11,12,13) and E10 with E18, provide a sequential mode of operation. That is:-

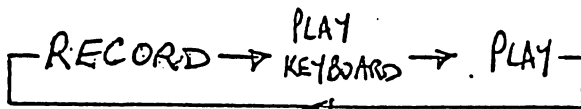

) these two
) sequences are
) permissible.
)

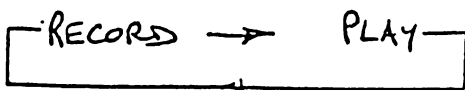
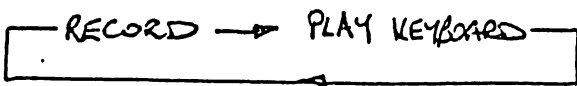

NOTHING HAPPENS



REMOVE FINGER - ALLOWS SEQUENCE TO PLAY.
PRESSING 'PLAY' MERELY STOPS SEQUENCE.

		RECORD	TOUCH K.B.	PLAY
E10	Q6	0	1	0-1
	Q8	1	1	0-1
		①	②	③ ③a

REVERTS BACK TO A 1 WHEN FINGER IS RELEASED

ASSUME E18/8 IS HIGH
E10/6 IS HIGH
E10/8 IS HIGH

1. The record pad is pressed. The data presented at the D input (2, E10) is high during the clock. Therefore Q goes high, \bar{Q} goes low. This sets E10 (* a low on its set input) and so the D type is latched up, and it will remain there until it is cleared. The \bar{Q} pin 6 is also connected to the clear of the lower E10 D type, but this has no effect as the D type is already in its cleared mode.
2. When the keyboard is pressed the KEY voltage (i.e. E18, 8) goes low, and this clears E10 (2,3,4,5,6). (The clear overrides the set control). The \bar{Q} output (E10, 6) then goes high, whereas the lower D type still remains unchanged.
3. Play is pressed. A logic high is presented to the D input (12, E10) and so the \bar{Q} goes low. However as there is no...
- 3a. latch up it returns to its high level as soon as the finger is released. Note, that when at the record mode, the clear input (13, E10) is low and so the lower half of E10 is prevented from changing state; that is, Record Play does nothing.

Control Logic This is E6. The logic sequence (Above) is presented to E6. The output sequence generated by E6 is as follows:-

	PIN	RECORD	KEYBOARD	PLAY
E6	(8	0	1	0 → no jump as above.
	(11	0	0	1

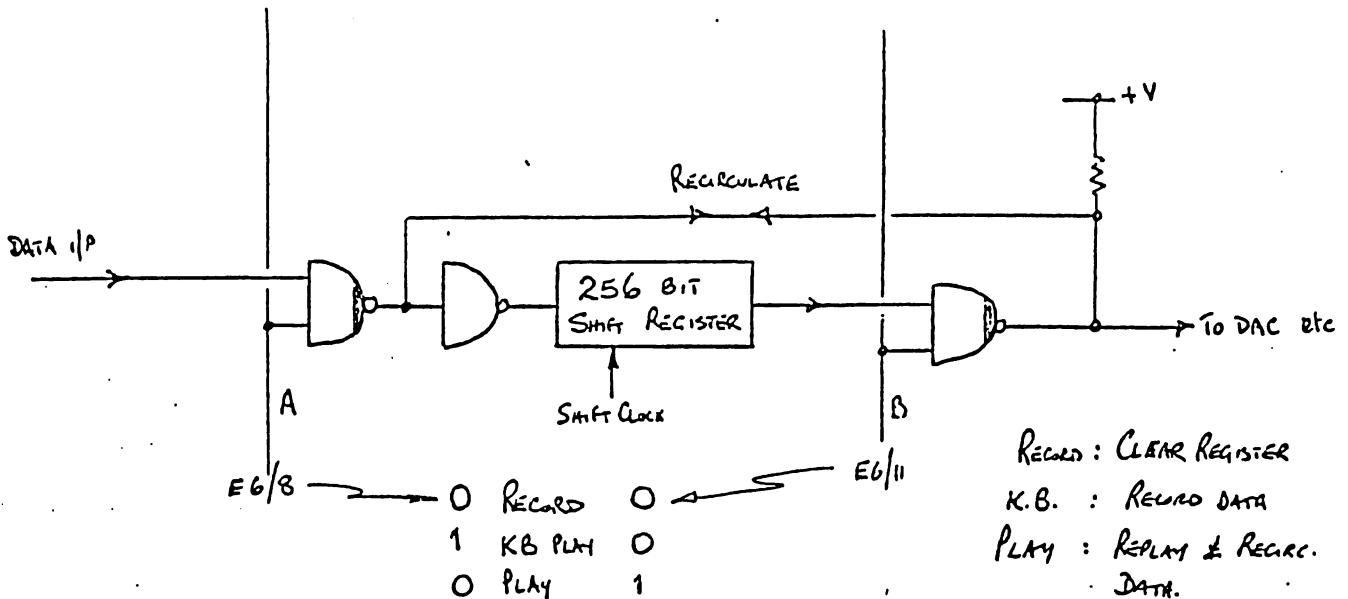

Lines A and B open and close the sets of input/output gates.

Only one set of gates (A or B) is ever open.

When the logic level on A is high, gates connected to it are open.

When the logic level on A is low, gates connected to it are closed.

RECORD Mode: BOTH SETS OF GATES ARE CLOSED. CLOCK TO SHIFT REGISTERS IS VERY FAST, LATTER FILLS WITH 0'S

KEYB'D Mode. This is "record" mode (confused?); data is accepted, because A is high. The data is clocked into the shift register at a slower rate, this rate being variable. If you are unlucky, you can overflow the shift register, and the front of the data is merely lost out of the end of the device.

Play. Data is replayed and recirculated; because line B is high. The replay clock rate is also variable. When an unfilled part of the shift register is detected a skip mode is implemented and the shift register skips all the blank locations until it finds the start of the data, which it then plays at its slow rate. Pressing the play pad stops the shift clock from operating in its "play" mode and so pressing play whilst the machine is replaying does two things:-

1. Effectively pauses the device
2. Upon releasing finger, the sequence restarts (preceded by a skip block).

If the shift register has been overflowed, then there are no blank locations and so when the play is pressed, the machine rapidly searches for an empty location and cannot find one. The result is a buzz sound as all the data rapidly recirculates. Also, as there are no blank locations, the machine does not know where the sequence start is. Therefore overflowed sequences, when replayed will start anywhere.

The memory is a 6 bit word, 256 bits long. 5 bits are used to record the note selected. The sixth is used to trigger the envelope trigger; that is if the envelope trigger pot is in the right position.

SHIFT CLOCK/SKIP GENERATOR

E19, Q14, C6, R71, R70, R72, VR3 is the high speed skip generator. It is a schmitt trigger oscillator. When C7 is operational the oscillator reverts to a low speed clock generator. In normal operation pin 8, E3 is low, C7 is thus effective and so a slow clock is generated. (Normal operation is during the recording and playing back, and not the pressing of those pads).

In normal operation, the output of E2 is high (i.e. the input is not all 1's) and so is the input pin 9, E3. When RECORD is pressed, all the inputs to E2 are high, the output of E2 goes low, and sets the skip oscillator into its skip mode, by making C7 ineffective. The shiftregister is thus filled with 0's. Also, the two meterdivider circuits E20, E24 are reset to zero.

When the KEYBOARD is pressed, the input gates to the shift registers are opened, and so the inputs to E2 change from all 1's to a mixture of 0's and 1's. (Note an all 1's condition cannot occur in normal operation). The output of E2 goes to 1. Thus, the output pin 8 of E3 goes to 0, C7 is functional so the oscillator begins to clock in its slow mode. Also, the reset on E24, 20 is in its count mode, the clock being taken from E19 pin 8. The output from E19, 8 is differentiated by C16, R68 to give a very short pulse, which appears at Q13's collector, and is used to drive all the shift registers.

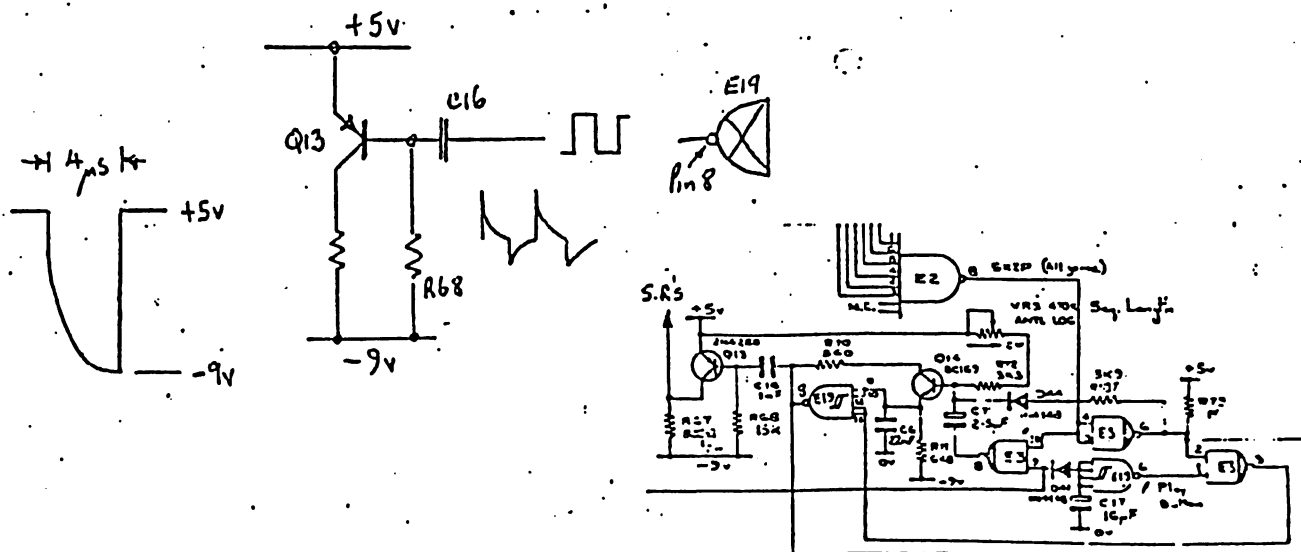

When the PLAY pad is pressed. Input pin 9, E3 goes low (but only for the duration of the pressing of the pad); this causes the data to rapidly recirculate (skip), usually for one bit only (because E3, 8 is high).

E3, 9 is low. Hence E19,6 is high.

E2, 8 is high.

Nothing happens until an "all low-state" of the shift registers is detected by E2 (*all 1's as seen by E2). When this state is located, E2, 8 falls to 0, therefore E3, 6 goes high, and in doing so resets E20, E24. Also, there are now two high's at the input to E3, (1,2,3) and so E3, 3 goes low and in doing so disables E19 (8,9,10,12,13) the oscillator. If there are no empty storage locations, the network just rapidly recirculates, and a "buzz" is heard.

When the play pad is released, pin 9, E3 goes high, however E3, 8 still remains high; E19, 6 takes a short time to go low because of the effect of E17. (This eliminates spurious effects when operating the play pad.) When E19,6 goes low, E3, 3 goes high, thus enabling the clock oscillator. The clock is in its high speed mode (skip) and so it races past all the unused storage area and when it comes to the first piece of data, E2, 8 goes high, the clock thus reverts to its slow speed mode, and E24, E20 is set to its count mode. Thus, the stored data is replayed, and when the end is reached there is a rapid skip and the process repeats itself.

METER COUNTER

The clock is divided by 16 twice, which is 256, the length of the memory. The 5 most significant bits are decoded in the meter DAC. This is E24 and the resistor network. The network is a "weighted/ladder" - (a Cockeral special).

LSB

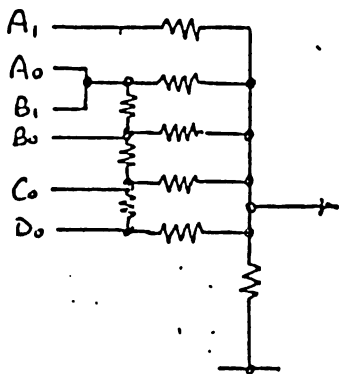

MSB

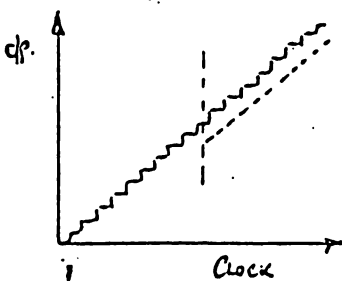

THE BIGGEST ERROR IN LINEARITY COMES 1/2 WAY WHERE A PRONOUNCED STEP CAN SOMETIMES OCCUR.

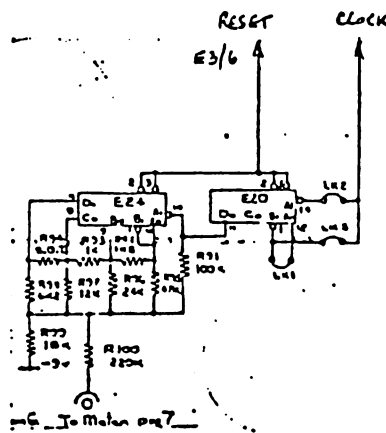

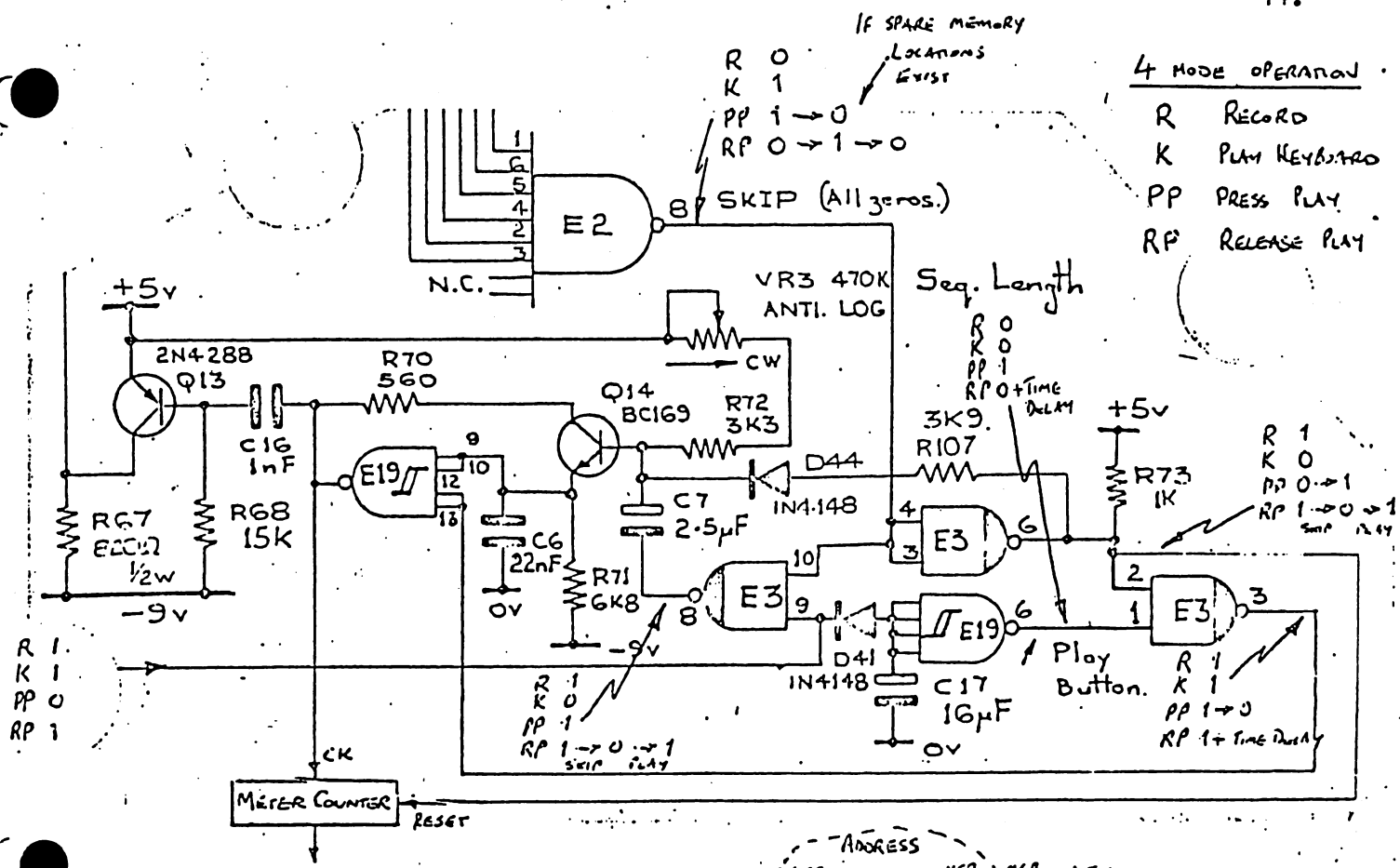

MEMORY DAC

The second DAC is a 5 bit device with a 6th bit controlled by the transposition pad. The "transposition pad" bit is the same order of magnitude as the MSB of the address bits.

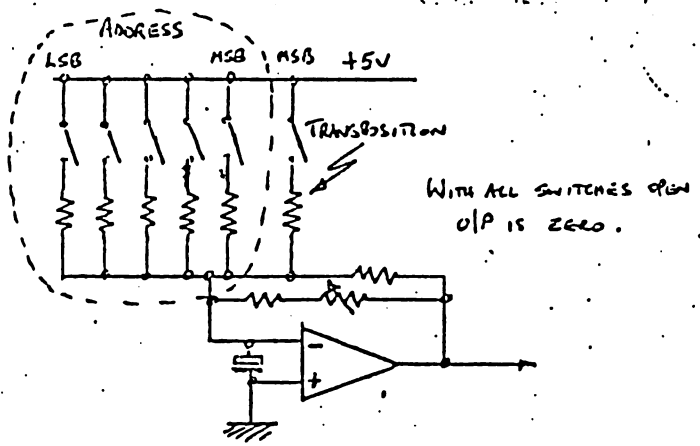

The switches are transistors Q7 and Q8-Q12 and the operation is similar to the real time DAC. Note, that the transposition acts only on the recorded output DAC, but no record of transposition playing is stored in the memory. Transposition is real time only.

TRANSPPOSITION.

The transposition multiplexer operates in a similar manner to the two other multiplexers. One difference is a feed-back circuit E11 (8,12,11) that causes single events to be multiplied. Looking at E7, we have:-

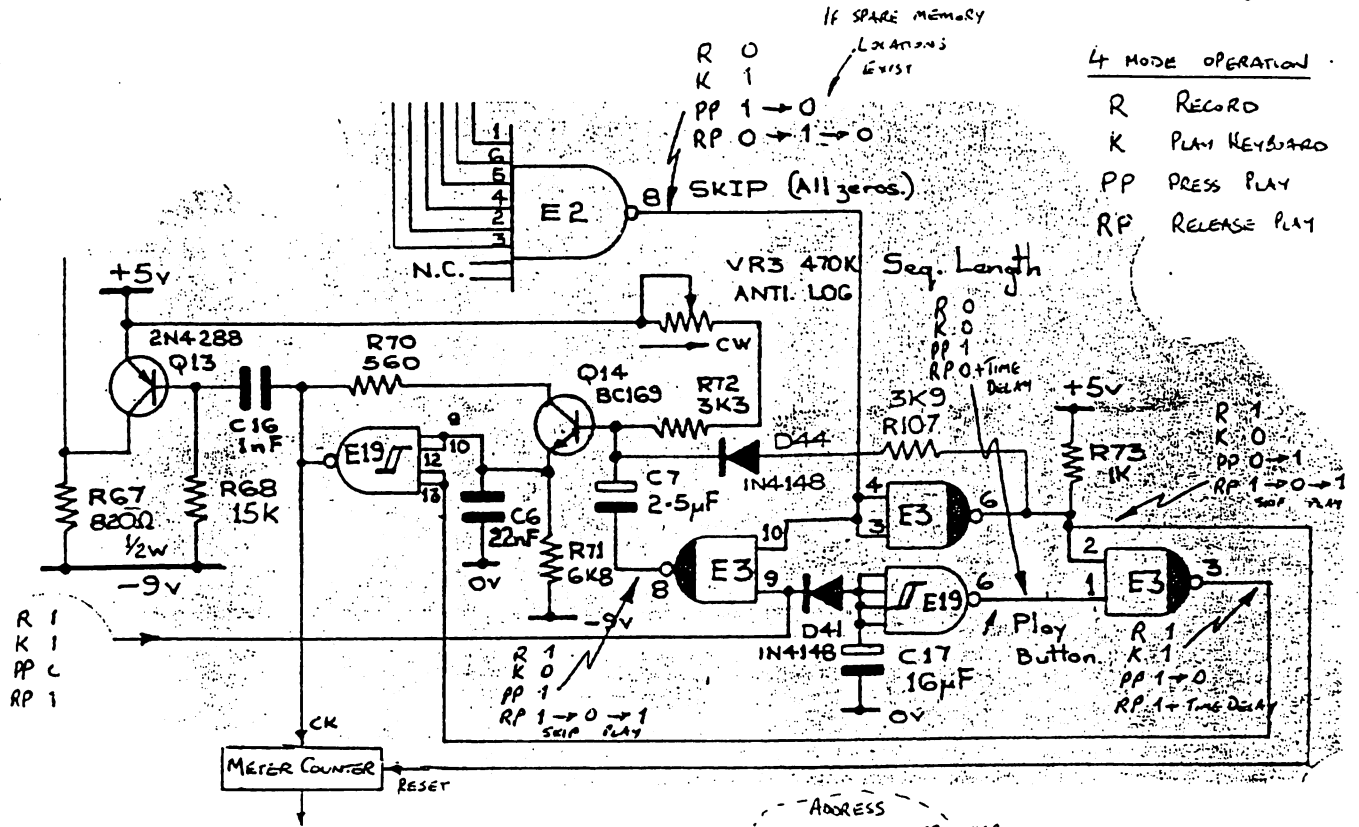

MEMORY DAC

The second DAC is a 5 bit device with a 6th bit controlled by the transposition pad. The "transposition pad" bit is the same order of magnitude as the MSB of the address bits.

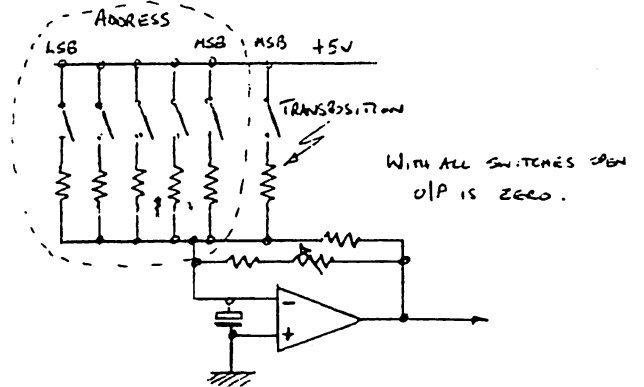

The switches are transistors Q7 and Q8-Q12 and the operation is similar to the real time DAC. Note, that the transposition acts only on the recorded output DAC, but no record of transposition playing is stored in the memory. Transposition is real time only.

TRANSPPOSITION.

The transposition multiplexer operates in a similar manner to the two other multiplexers. One difference is a feed-back circuit E11 (8,12,11) that causes single events to be multiplied. Looking at E7, we have:-

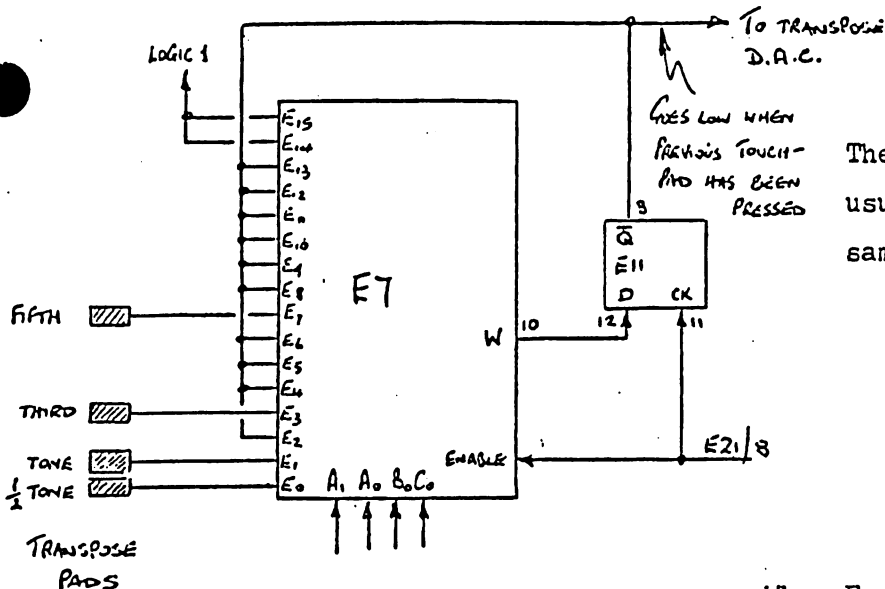

The multiplexer is addressed in the usual way, and is enabled and has the same touch sensitivity as before.

When E0 is pressed, it is prevented from going high, and so the output at W is high for E0.

therefore pressing E0 produces a 1 bit pulse at E11 pin 8.

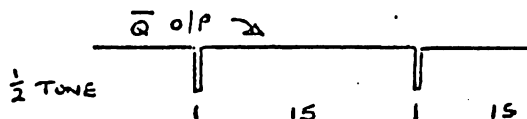

Pressing the tone causes W to be high for E1. But the output \bar{Q} of E11 is fed back to E2. And so when E2 is addressed the output is again high but stops when it gets to E3.

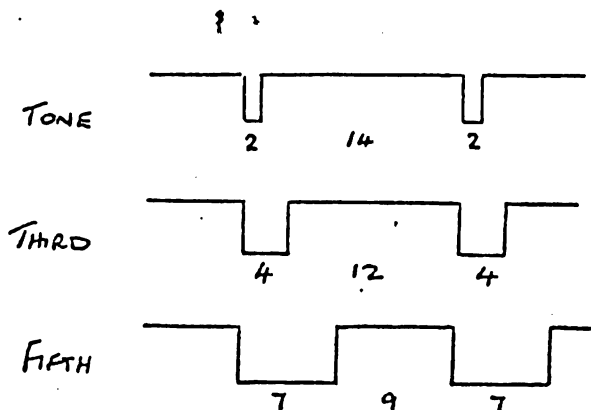

*Notice E14, E15 are never low.

Now, the output from E11 pin 8 is used to control the DAC on the recorded output. As the transposition signal is a mark/space ratio signal, then the resultant product from the DAC must be smoothed out, this being accomplished by C5. The transposition signal is used to control a logic switch of equal status to the MSB of the 5 bit DAC.

The thirty notes available from the keyboard form $2\frac{1}{2}$ octaves, (i.e. 12 notes per octave). Therefore 12 logic bit = 1 Octave
 or 1 semitone = 1 logic bit.
 where 1 octave = 12 semitones.

The MSB of the address is equivalent to 16 logic bits. Therefore as the transpose controls a switch of equal status to the MSB, then one bit of the transpose signal = 1 semitone.

Therefore, pressing the $\frac{1}{2}$ tone pad = 1 bit = 1 semitone.
 pressing the tone pad = 2 bits = 2 semitones.
 pressing the third pad = 4 bits = 4 semitones.
 pressing the fifth pad = 7 bits = 7 semitones.

that is, pressing the keyboard and the transposition pad, transposes the note generated upwards by the respective amount.

* Example:- pressing the $\frac{1}{2}$ tone, third and fifth will shift a note up by one octave. (That is, if the keyboard has been adjusted to $2\frac{1}{2}$ octaves)
 $1 + 4 + 7 = 12$ semitones = 1 octave.

(* An octave - the ratio of two frequencies which are at frequencies of F and 2F. F being arbitrary).

APPENDIX

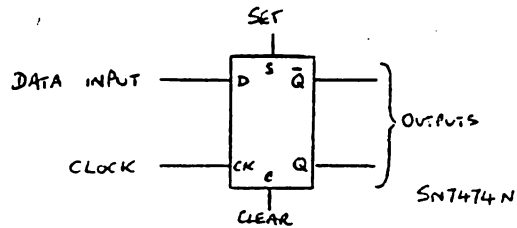

D type, used usually as a one bit delay or an edge detector.

Logic data is presented to the D input. The data (0 or a 1) appears at the Q output after the +ve edge of the clock pulse, that is:-

data is transferred to the Q output on the +ve edge of the clock:-

Set - a 0 on the set puts Q to 1

Clear- a 0 on the clear puts Q to 0

set and clear are independent of the clock and override the D input.

SCHMITT

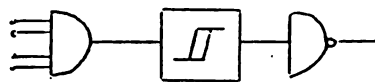

SN7413N

The SN7413N looks like a 4 input AND, followed by a schmitt trigger, followed by an inverter. The schmitt trigger exhibits a phenomena known as Hysteresis.

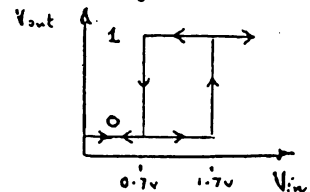

AKS Patch Sheet

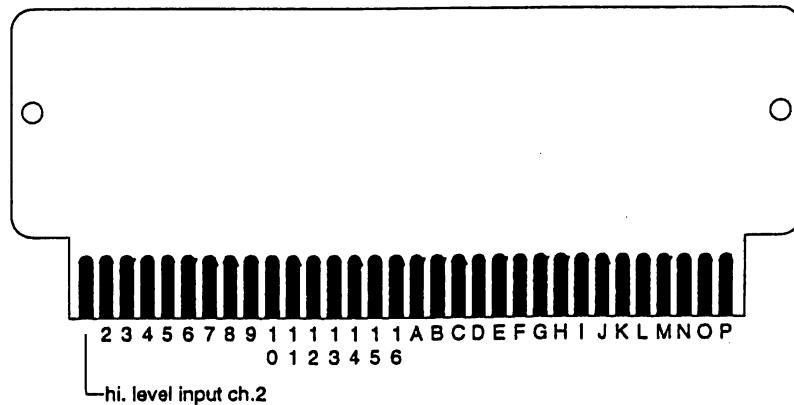
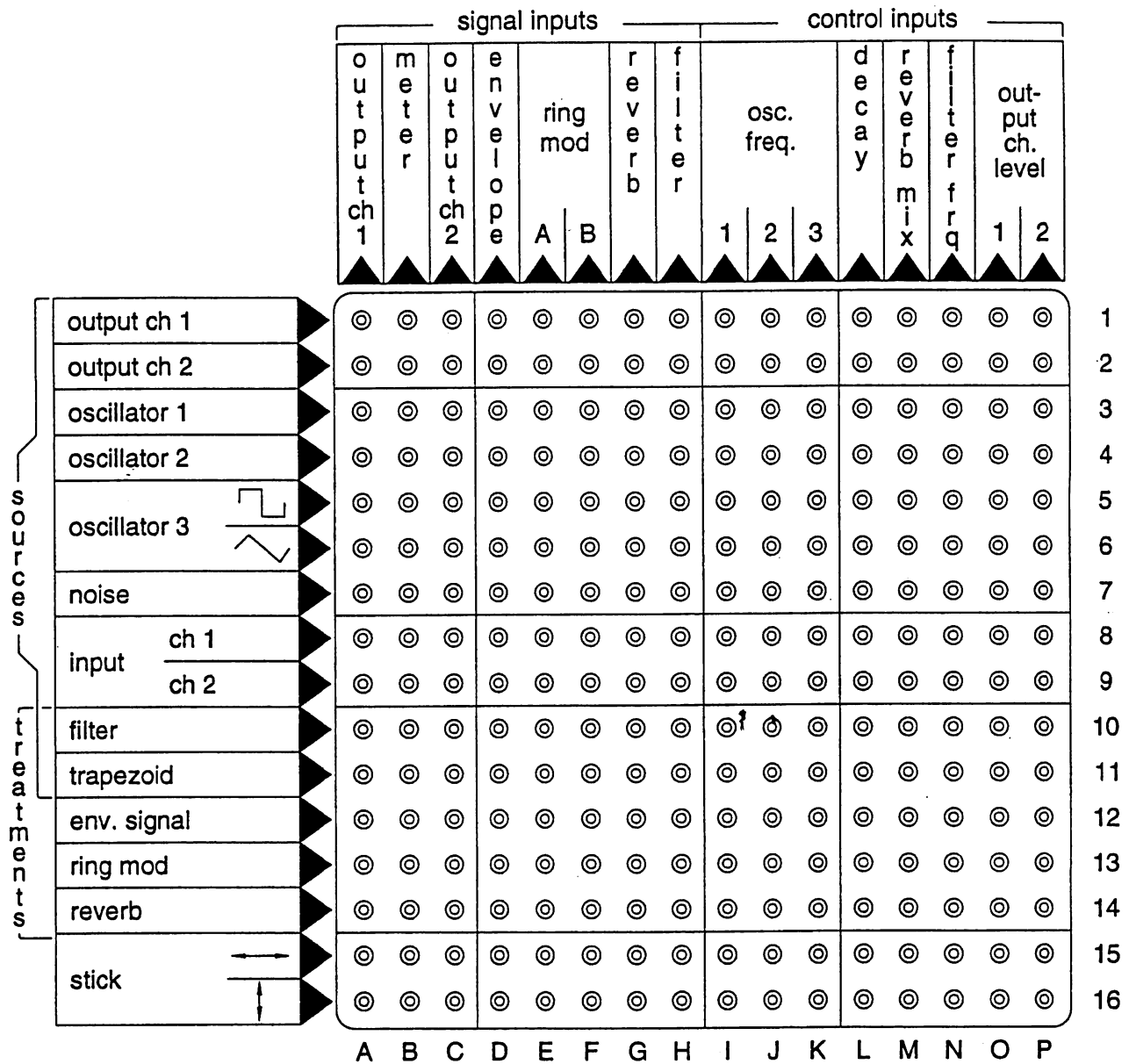

Ch. 1.

Ch. 2.

Tone Control F.E.T. Mod. Iw. Amplifier
control. voltage summer.

Tone Control F.E.T. Mod. Iw. Amplifier.
control. voltage summer. +12v

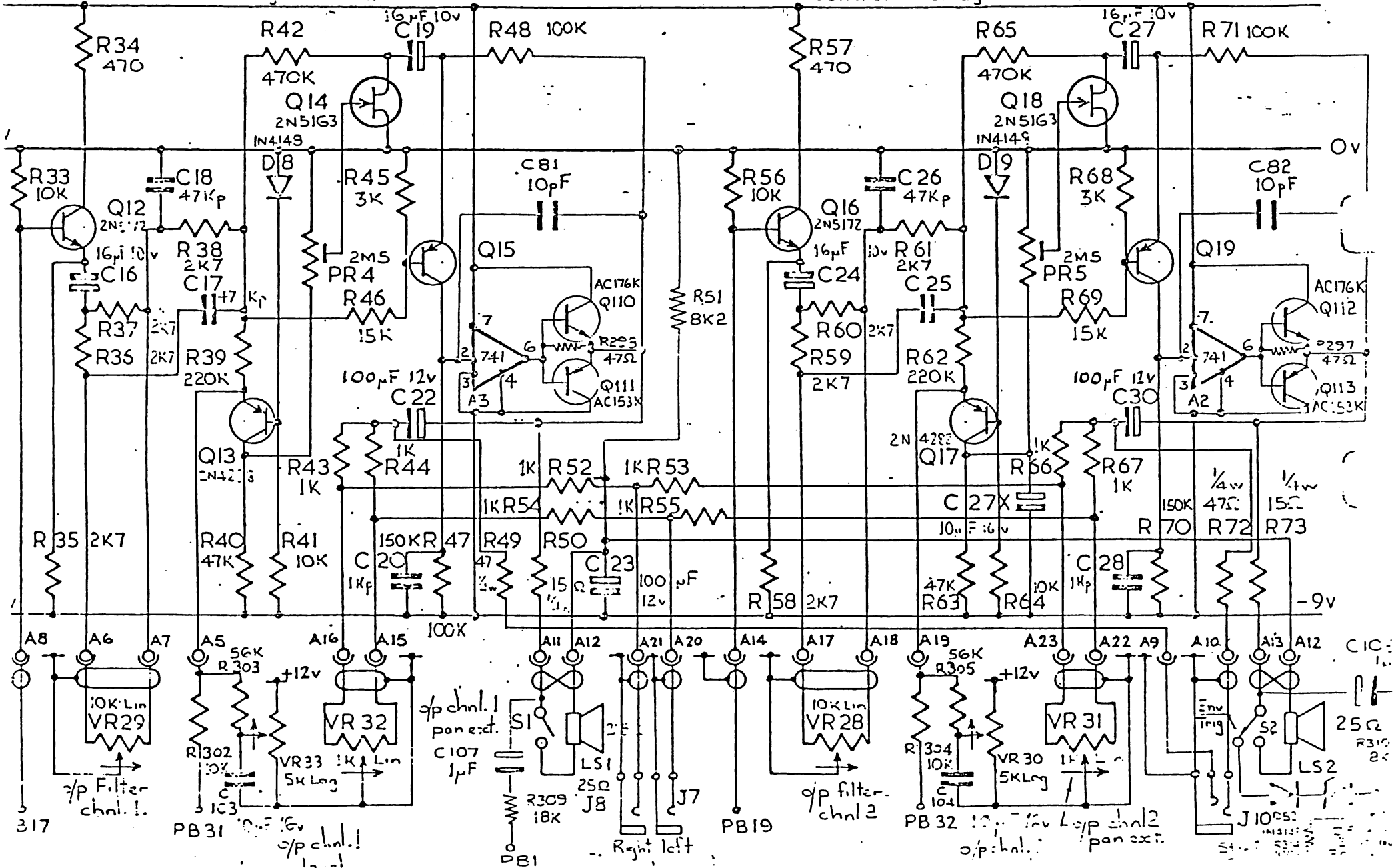

Hi-Zo drive amplifier.

Pick-up amplifier & voltage controlled mixer.

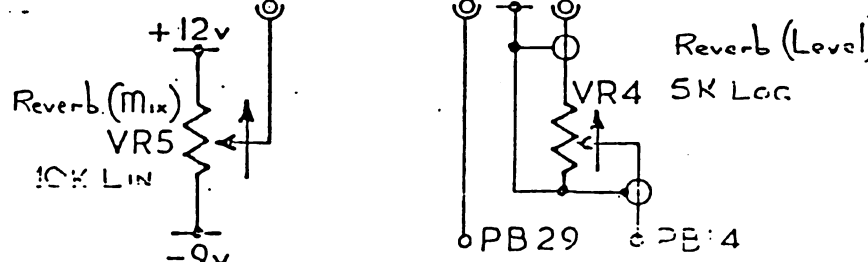
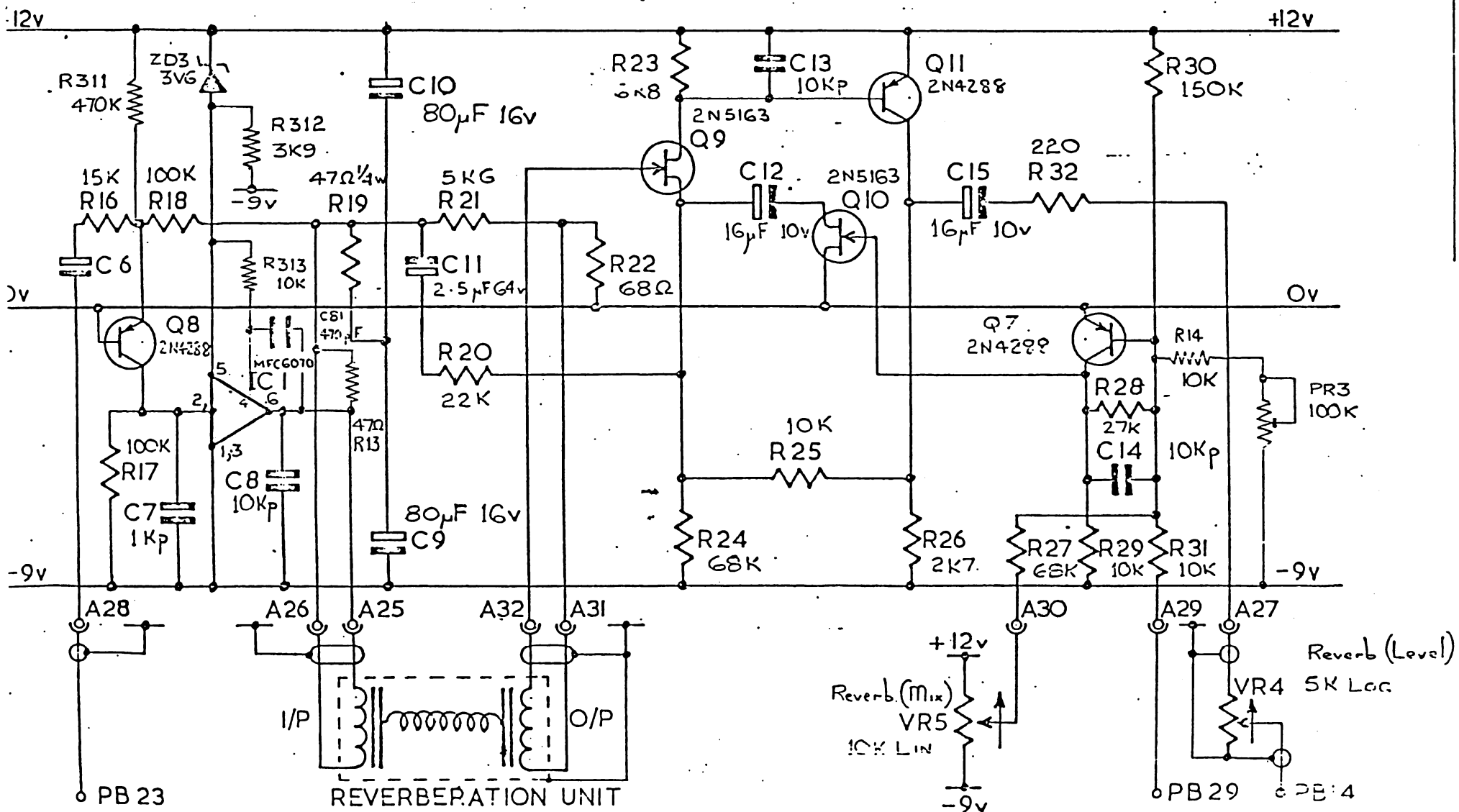

NOTE 1 Q14 & Q18 MATCHED FOR V_p & I_{oss} .

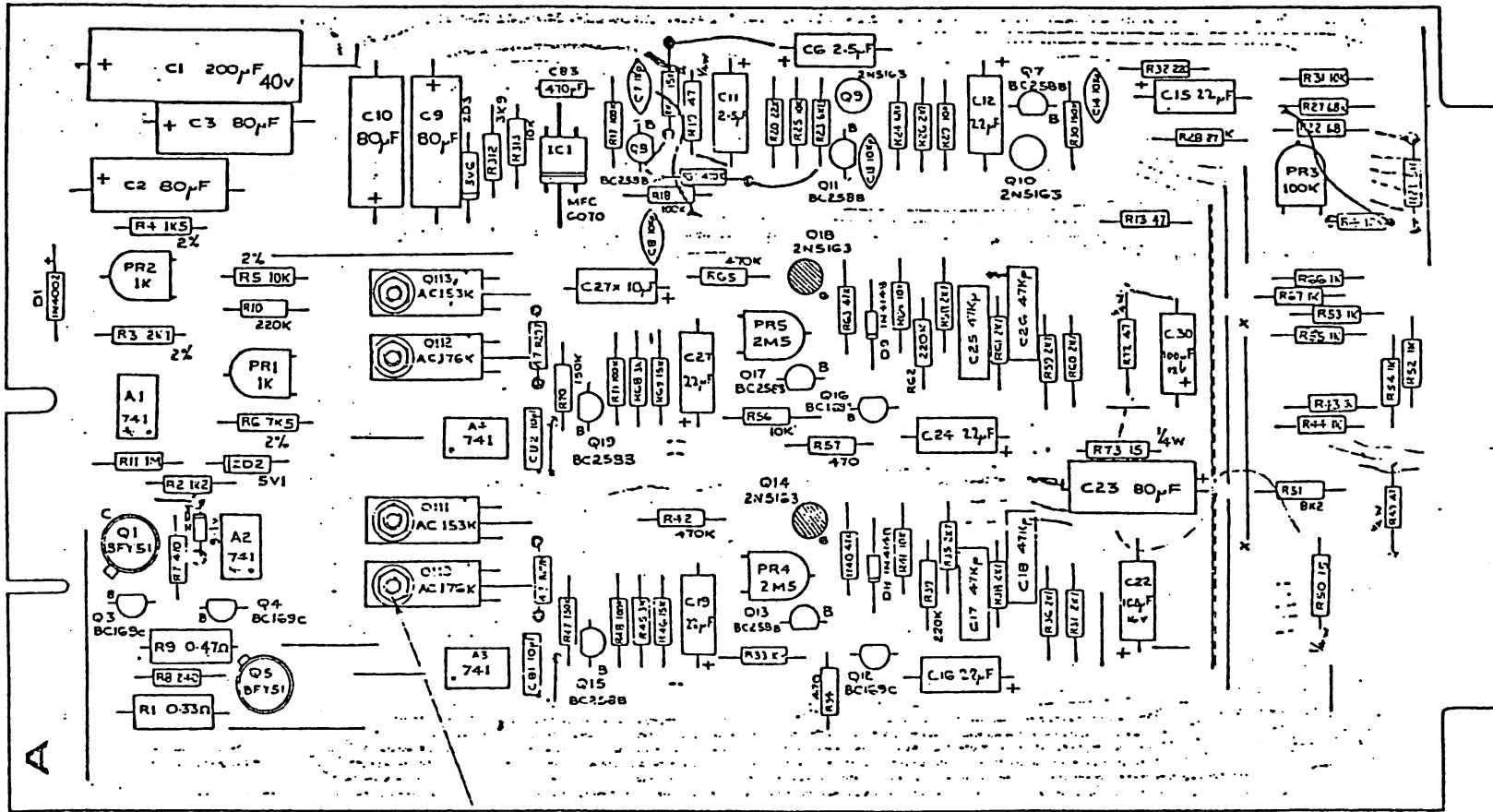

- 32 > Reverb o/p
- 31 VR5 (w)
- 30 PB29
- 29 PB23
- 28 PB23
- 27 VR4
- 26 > Reverb i/p
- 25
- 24 0V
- 23 VR31
- 22 VR31
- 21 J7 (E)
- 20 J7
- 19 PB32
- 18 VR28
- 17 VR28
- 16 VR32
- 15 VR32
- 14 PB19
- 13 LS2
- 12 LS1 & LS2
- 11 LS1
- 10 J10R
- 9 J10T
- 8 PB18
- 7 VR29
- 6 VR29
- 5 PB31
- 4 +12V OUT
- 3 -9V OUT
- 2 -D.C. IN
- 1 +D.C. IN

- O. C.N. 82, R. 13-8-73.
- F. NOTES 1-5 ADDED 22.11.73
- E. C.N. 29, R.C. 2-4-73.
- C.N. 44
- D. C.N. 33, 5/3/73
- C Power Amp. Redesign 2/2/73

HILTON ELECTRONICS
MIAMI BEACH, FLA.

TITLE 'A' BOARD
SYNTHI AKS (15)

ISSUE	DATE	BY
1	11/22/73	
2		
3		
4		
5		
6		
7		
8		
9		
10		

Mounting Holes to be used
on Q1 & Q5 TSS type

+ 6BA - 1/2 CH (6-5M) + FULL NUT & 5 PAPER

* ALL VAL TYPES TYPE PREFERRED

- NOTE: 1. C1 SHOWN AS 25V ON BOARD
- 2. R34 VALUE (i.e. 470 NOT SHOWN ON BOARD.
- 3. LINK BETWEEN POINTS X-X NOT SHOWN ON BOARD.
- 4. POS. NOT SHOWN ON C16.
- 5. C.N. 19, 16, 17, 22, 24, 27, 30 SHOWN AS 40µF ON BOARD.

CH. I.

Hi gain Mic/operational amplifier.

CH. II.

Hi gain Mic/operational amplifier.

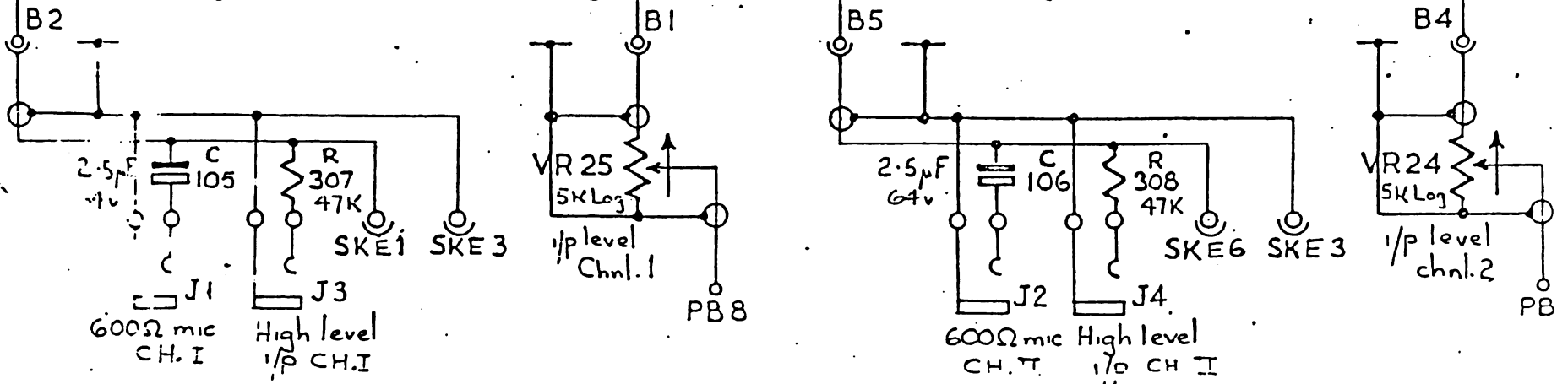
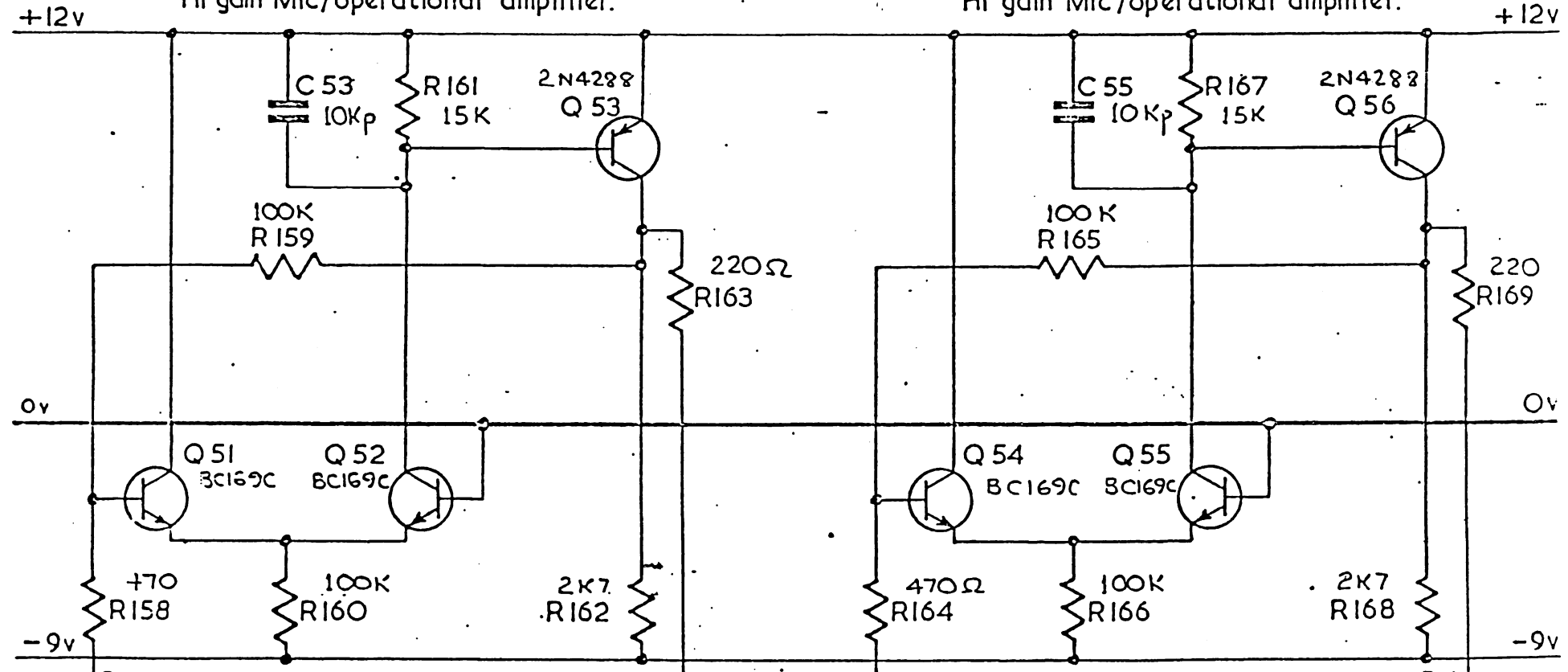

Anti-log freq. control
summer.

Ladder filter
Signal phase splitter.

F.E.T. feedback control.

Differential signal amplifier.

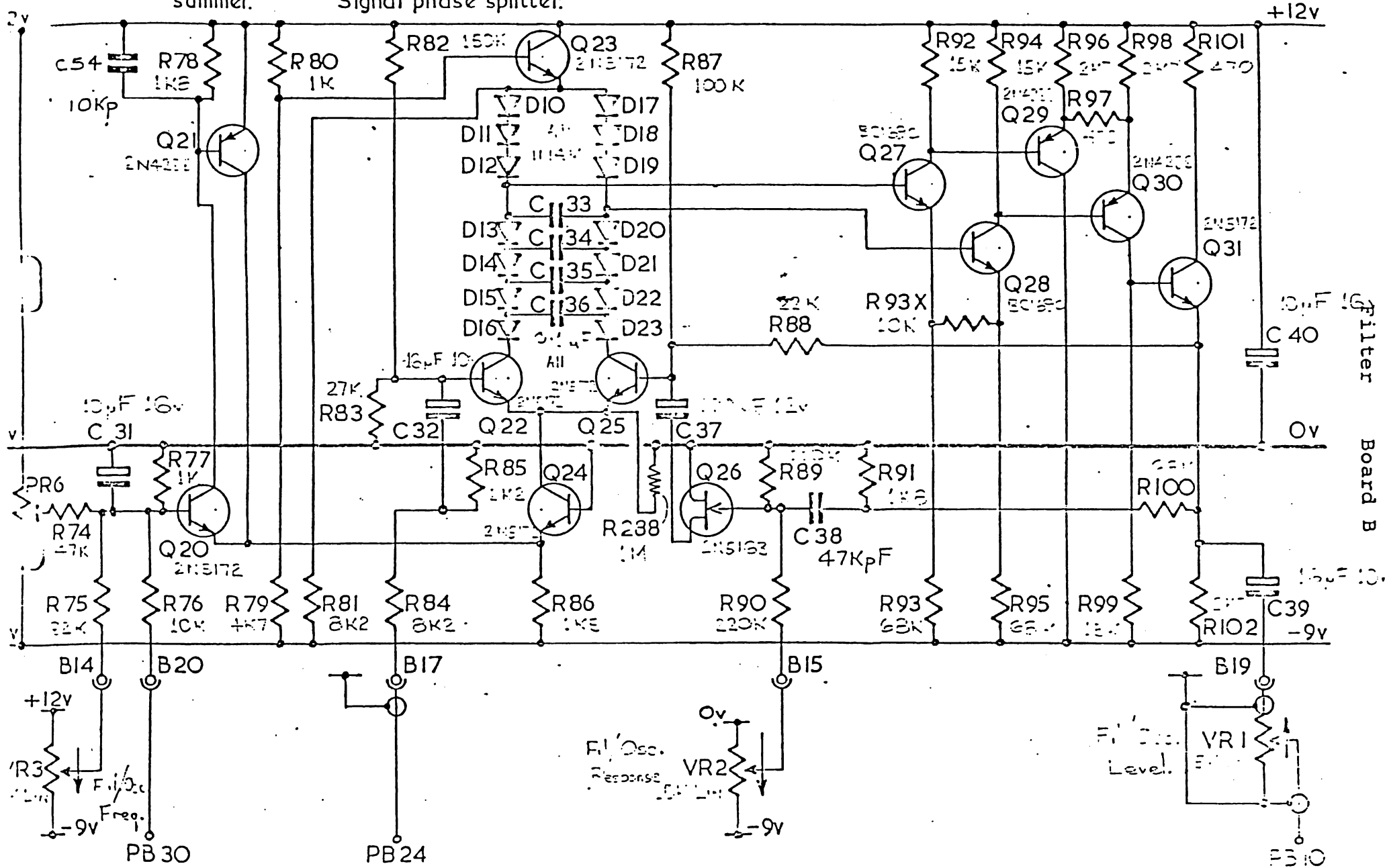

of proper ON-OFF times

Trapezoid should be even I around Zero - Select R139
ON time infinite Reduce R148
off " " increase R148

Envelope Shaper
Board B

Anti-log decay
control summer.

Clamped integrator for
attack & decay slope.

RC integrator for
on & off times.

Hysteretic
switch.

Linear
modulator.

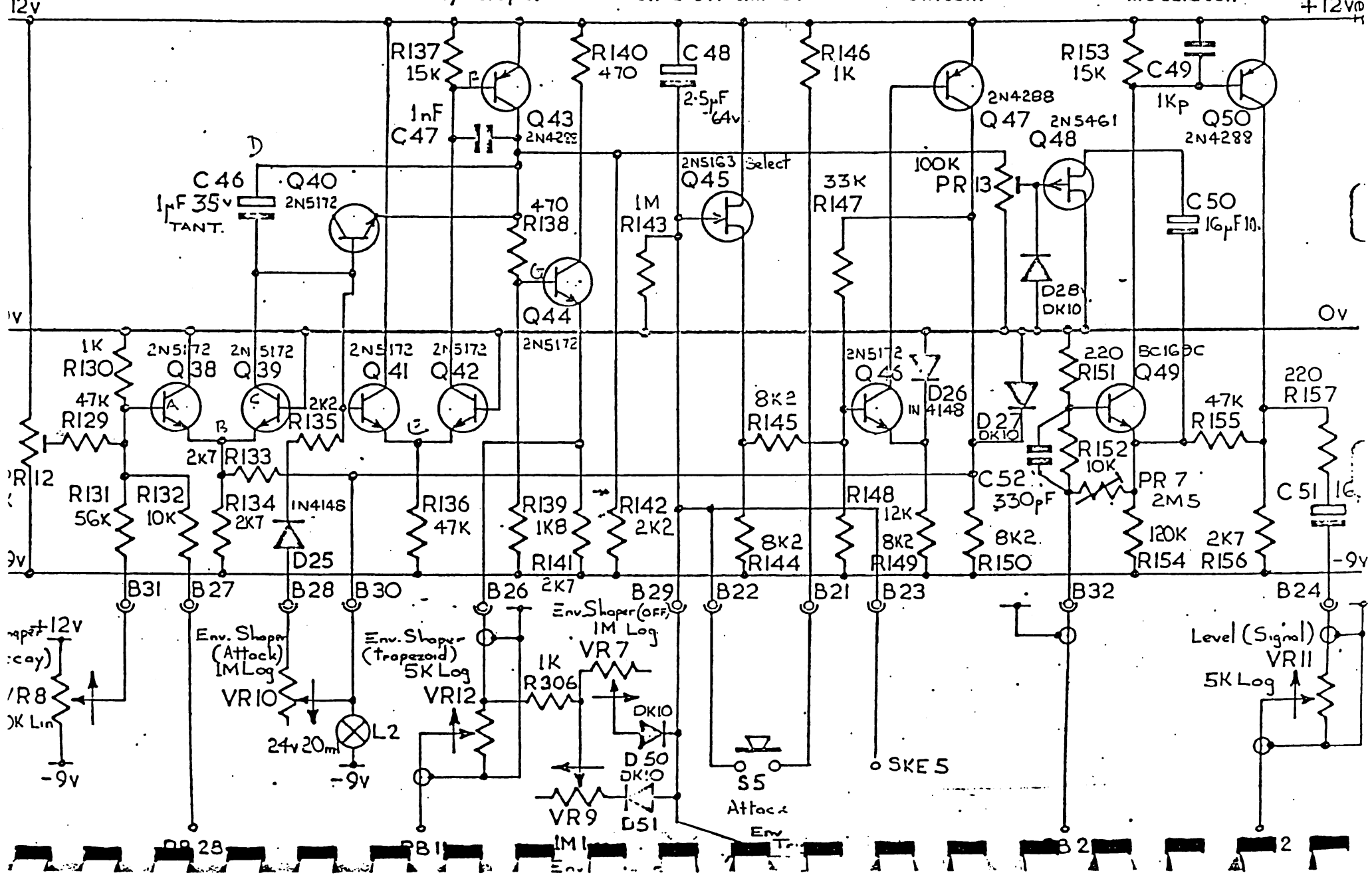

Double balanced modulator

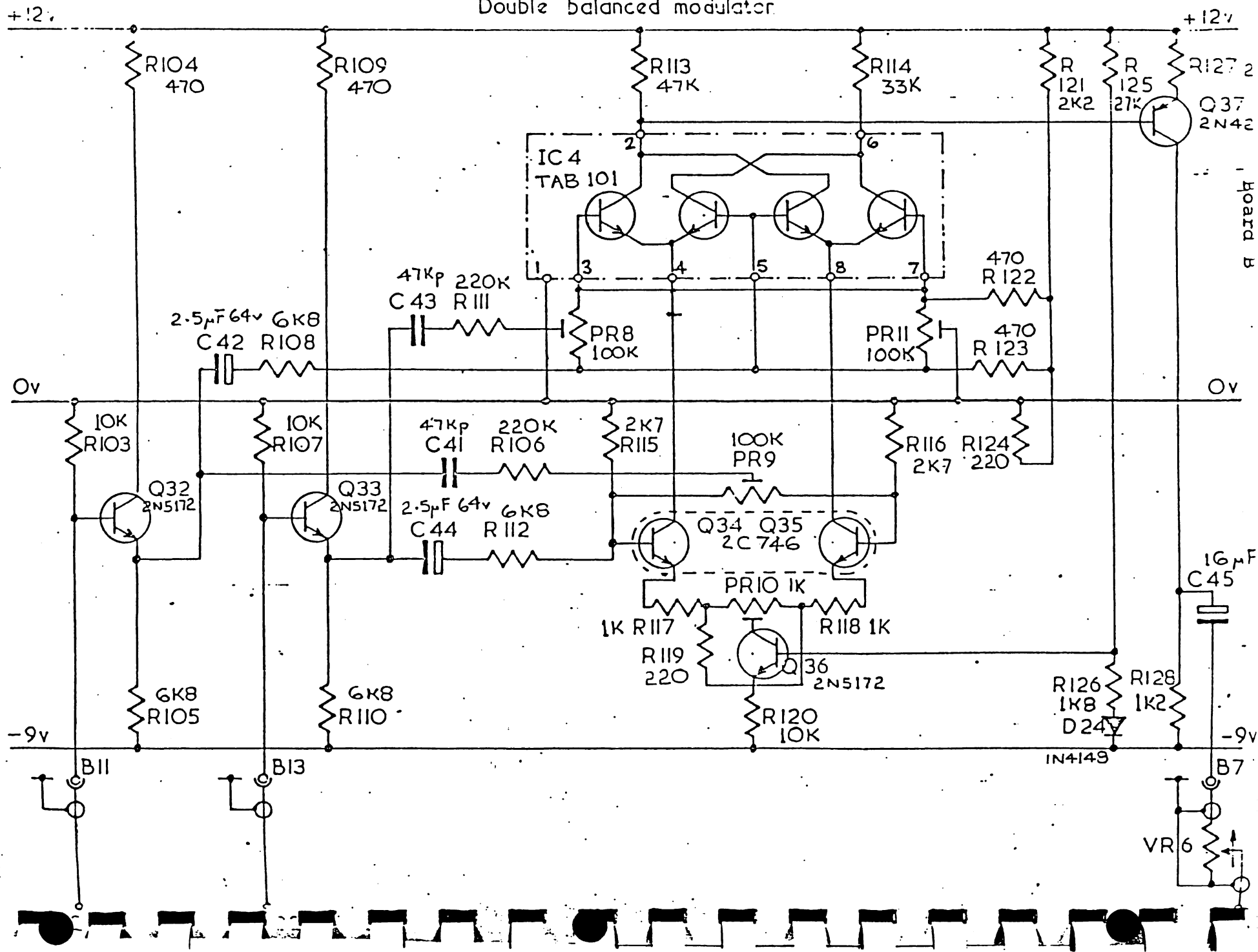

NOISE GENERATOR.

METER AMPLIFIER.

+12v Noise source. Amplifier. Tone network.

D.C. voltage follower. Rectifier.

+12v

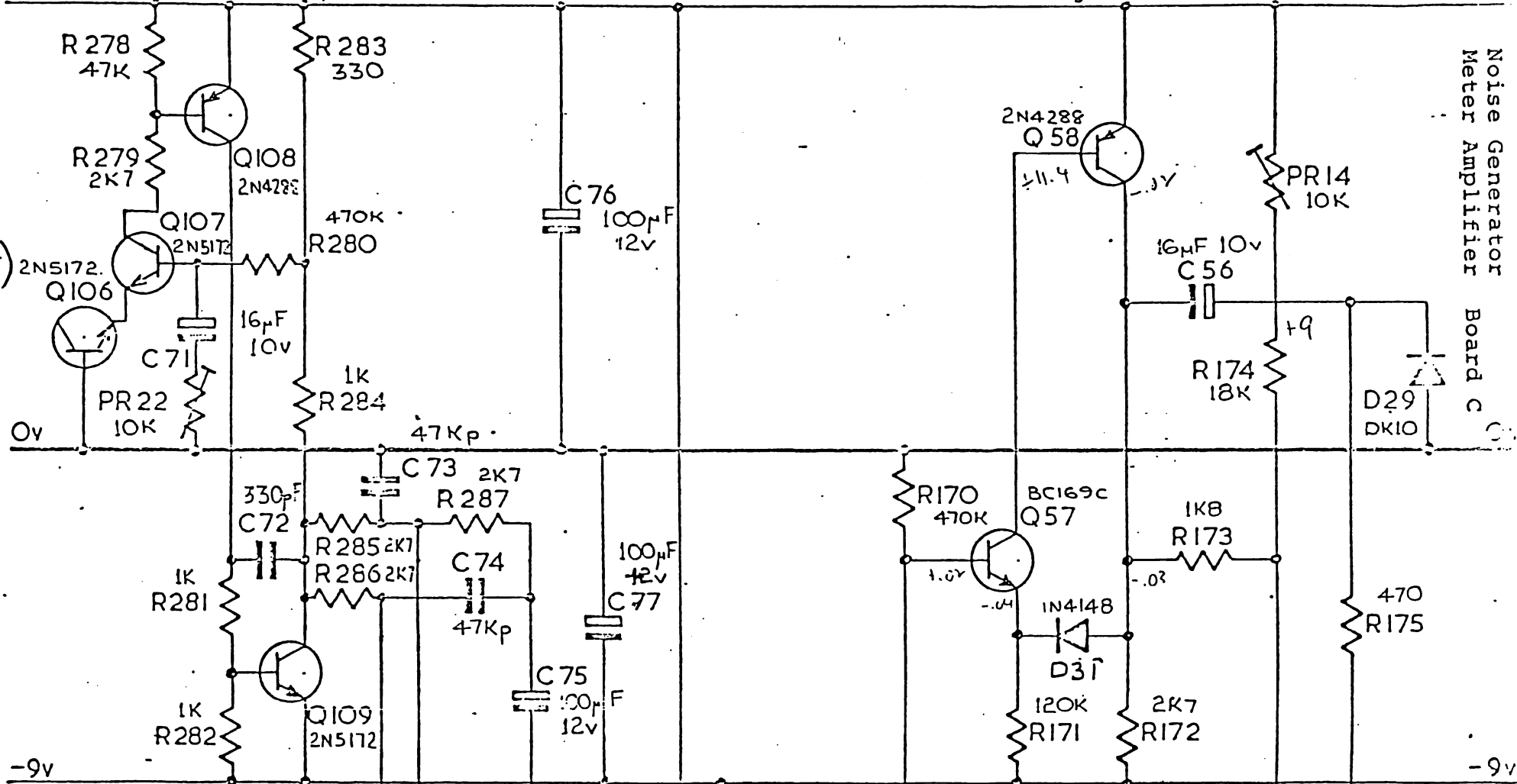

Noise Generator
Meter Amplifier
Board C

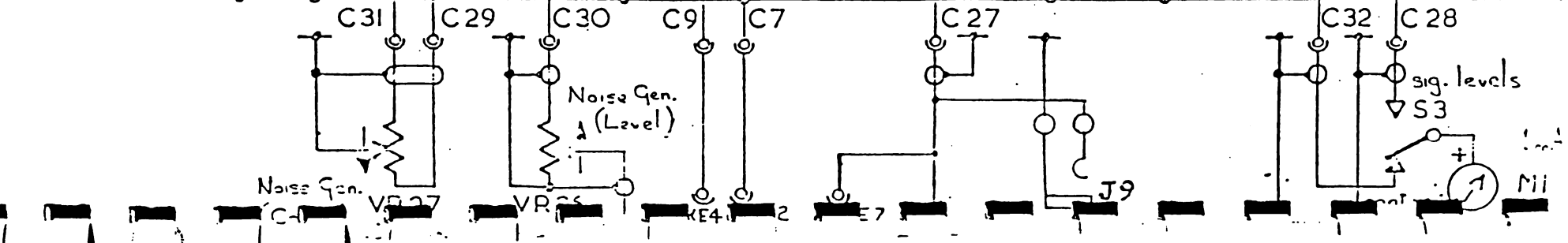

VCS 3 / 10000

ALL 2N5172 HOW TO USE

Osc 1
board
C

frequency
control summer

Ramp integrator

Hysteretic switch

Triang to sine shaper

+12v

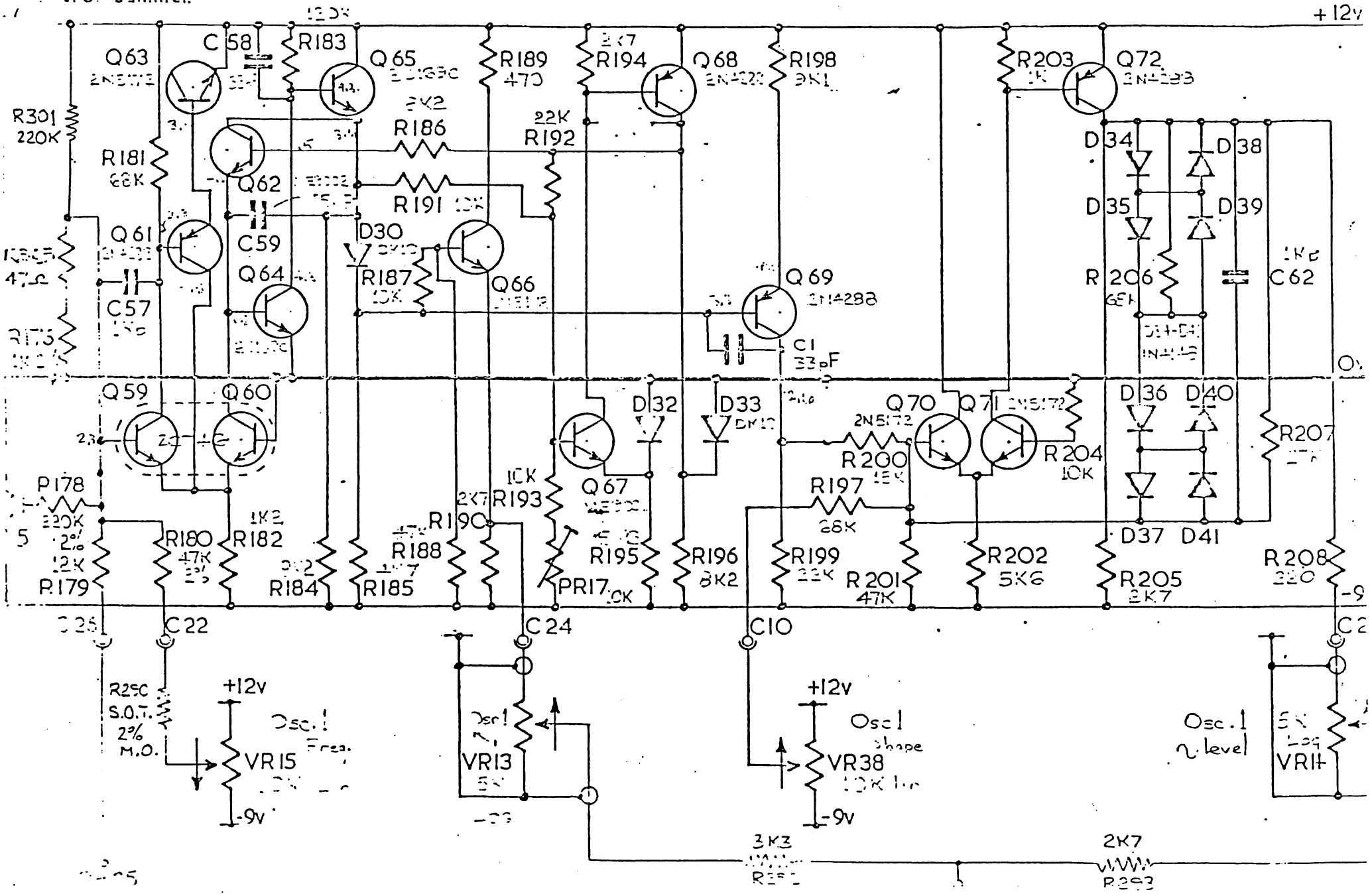

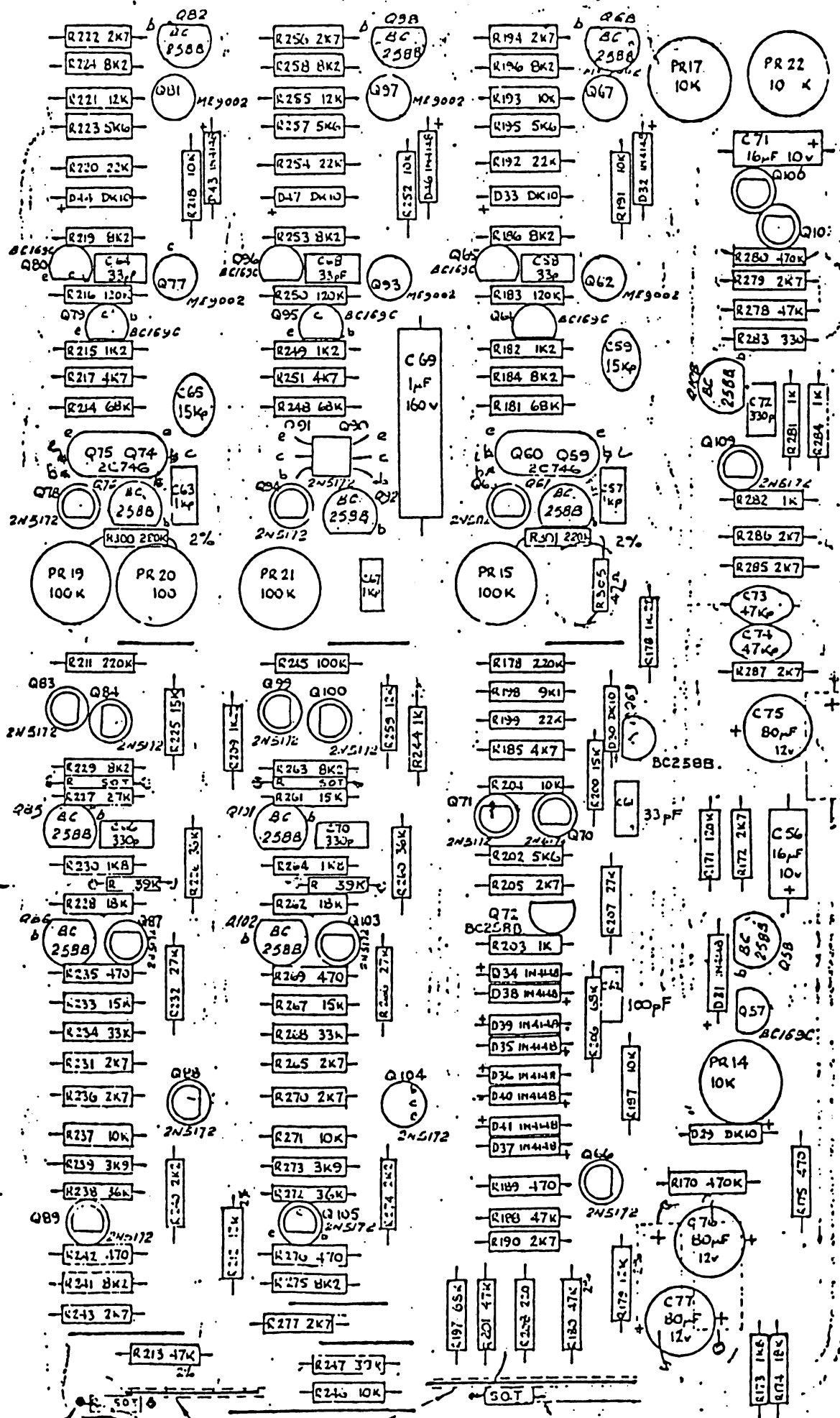

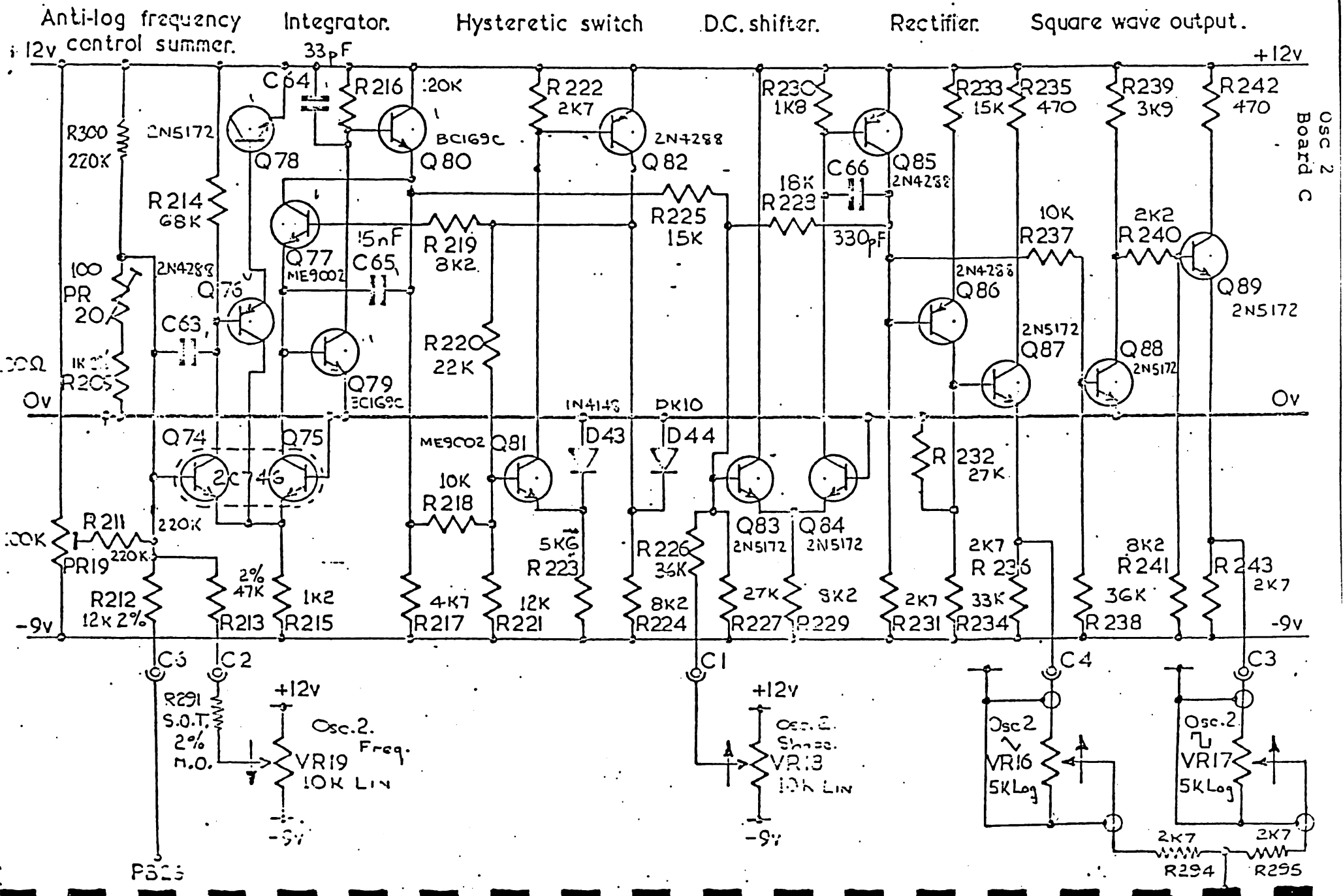

Anti-log frequency control summer. Integrator. Hysteretic switch. D.C. shifter. Rectifier. Square wave output.

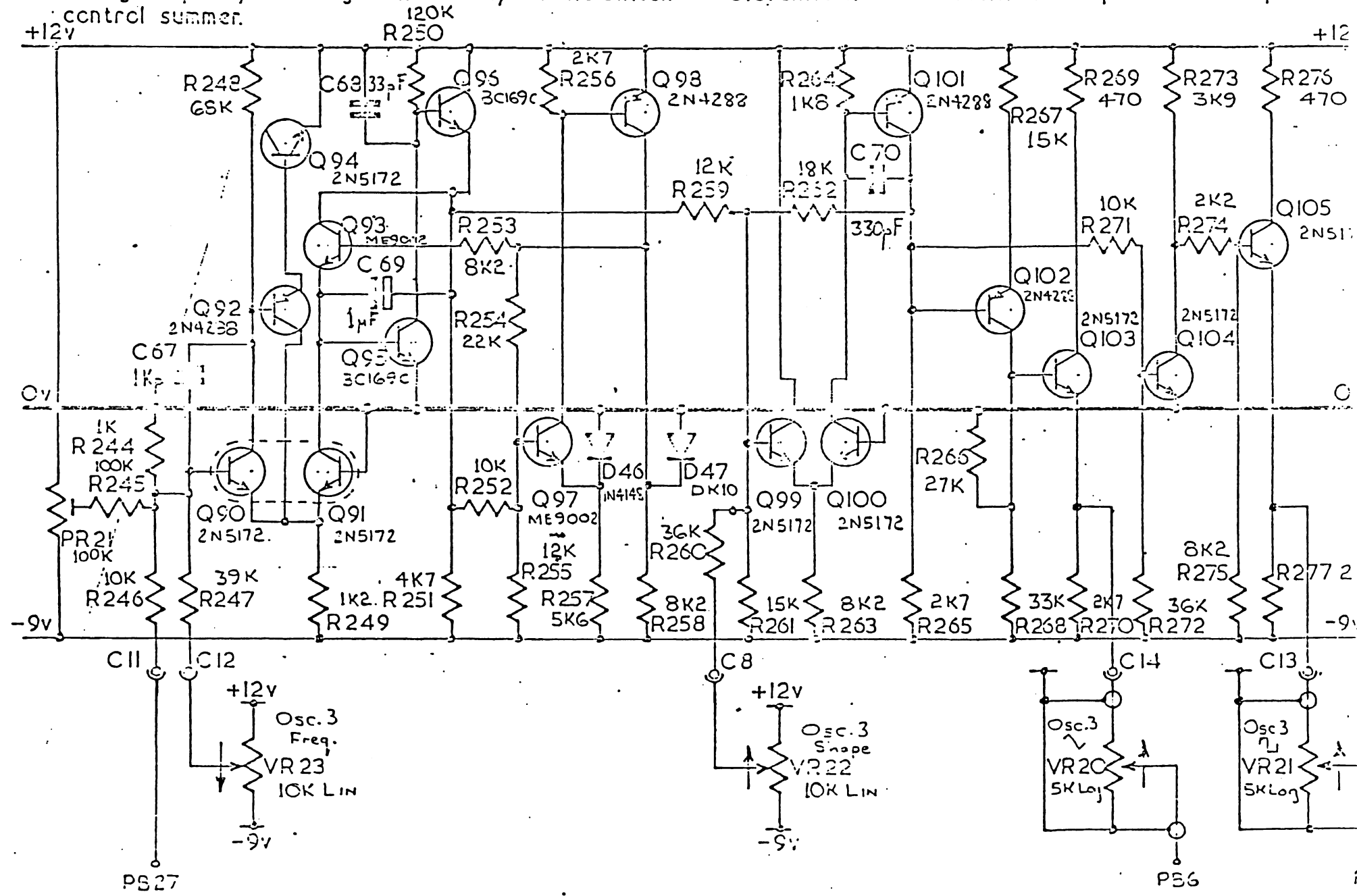

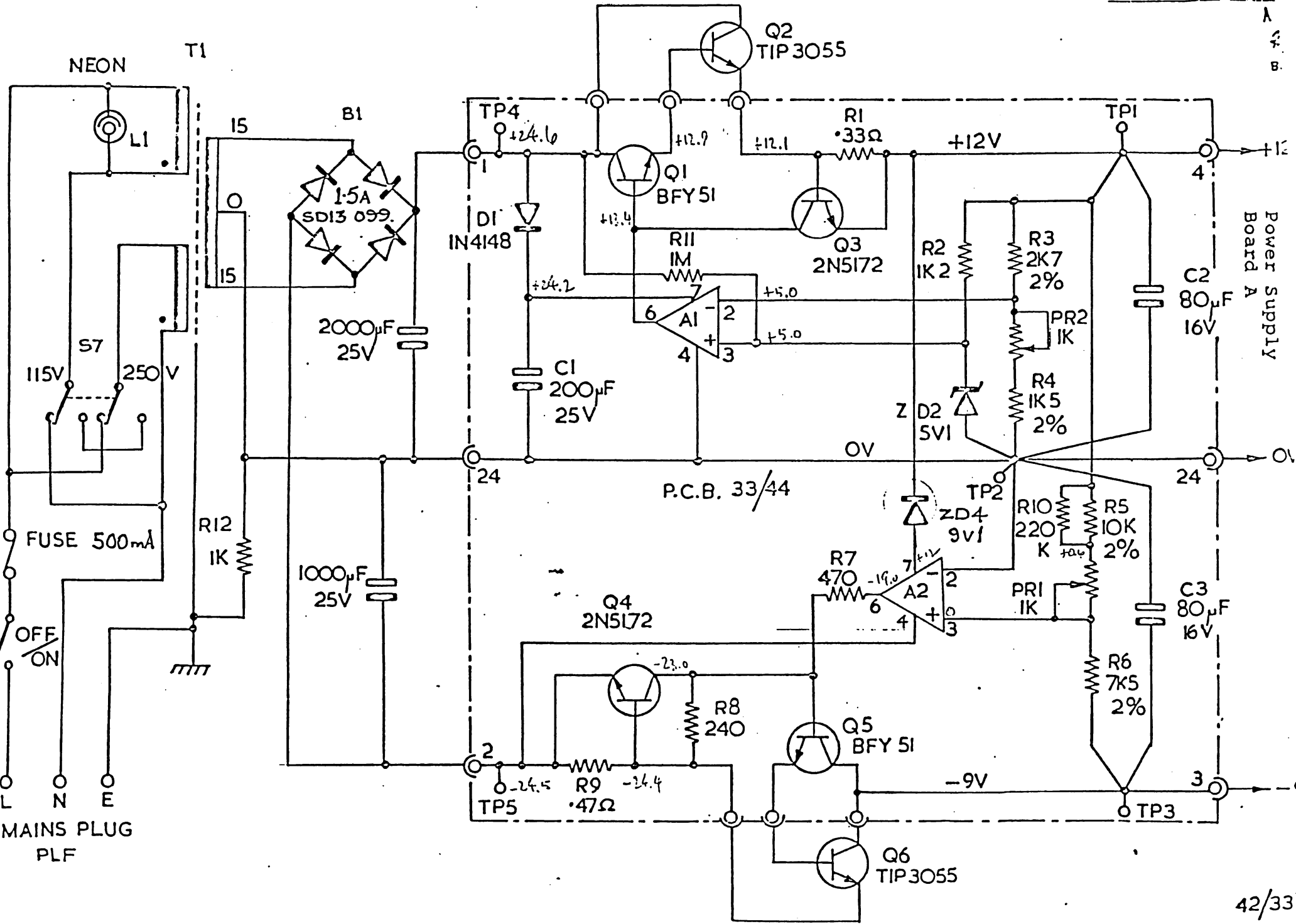

S E R V I C E M A N U A L

Synthi A/VCS3
DK1/2 keyboard
KS sequencer

Compiled by Electronic Music Studios, Trendeal Veau Barn, Ladock, Truro TR2 4NW.

Telephone 0726-883255

We reserve the right to make changes in technical specification and design
in the interest of continuing improvement in performance.

CONTENTS:

Section 1	Synthi A/VCS3
Section 2	KS keyboard
Section 3	DK1 and DK2 keyboard

NOTE:

Transistor types used in our machines have varied from time to time.

The following types are the most widely used:

NPN sil BC 169C 2N 5172

PNP sil BC 258B 2N 4288

Fast NPN sil ME9002 2N 706

Fet 2N 5163

Fet 2N 5461

Diodes:

DK10 - small signal germanium

1N4148 - 1N 914

SYNTHI A ALIGNMENT

Synthi A	Testing Manual Board
1. Power Supply	A
2. Output Channels	A
3. Reverberation	A
4. Envelope Shaper	B
5. Filter Oscillator	B
6. Ring Modulator	B
7. Input Channel Preamplifiers	B
8. Oscillator 1	C
9. Oscillator 2	C
10. Oscillator 3	C
11. Noise Generator	C
12. Meter Amplifier	C

}

Board A is on the left side as you look at the opened back of the machine.
Board B is in the middle, with Board C on the right.

SPECIFICATIONS

Power: 100-130V or 200-250V ac.
 Stereophones level: 10V p.p max into 50 ohms
 Scope output: 5V p.p max
 Signal output: 2V p.p max into 600 ohms
 Control output; 15V dc max into 10K ohm
 Signal Input; ac - 1.8V p.p into 50K ohm. dc- 2.5V max into 50K ohm.
 Microphone Input; 5mV into 600 ohms

Devices

Oscillator 1	Range: 1Hz-10kHz (on dial) Outputs: Sine 2V p.p (with shape control) Sawtooth 2V p.p Control Sensitivity; 0.32 Volts/Octave
Oscillator 2	Range; 1Hz-10kHz (on dial) Outputs: Triangle/Sawtooth 3V p.p Square/Pulse 2V p.p Control sensitivity; 0.32 Volts/octave
Oscillator 3	Range: 0.02(40"period) - 500Hz(on dial) Outputs: Triangle/Sawtooth 3V p.p Square/Pulse 2V p.p Control Sensitivity: 0.26 Volts/octave
Noise Generator	Level: 3V p.p white and coloured
Filter/Oscillator	Range: 5Hz-10kHz (on dial) Cut-off rate: 18 dB/Octave Q: Variable up to 20 Frequency Control : 0.2Volts/Octave
Ring Modulator	Input level: 1.5V p.p max. Output level: 6V p.p max. Input rejection: -50 dB (with 1.5V p.p input)

Envelope Shaper	Duration: Attack 2ms-1s On 0-2.5s Decay 3ms-15s Off 10ms-5s (+Off position)
	Trapezoid Output: $\pm 3V$ dc max.
	Decay Control; 0.4 Volts/octave
Reverberation	Max time: 2s Output Level: 5V p.p Mix VC : -2V for 0%, +2V for 100% mix
Joystick :	Voltage Output: 2 x $\pm 1.5V$ dc
Meter Input	Control Voltage mode: $\pm 1V$ dc Signal mode: 4V p.p
Input Amplifiers	Sensitivity: 1.8V for High Level Inputs 5mV for Microphone Inputs
Output Amplifiers	Output level: 2V p.p into 600 ohm (panned) 10V p.p into 50 ohm (unpanned) 5V dc into 10K ohm (unpanned) VC level: 15 dB/Volt

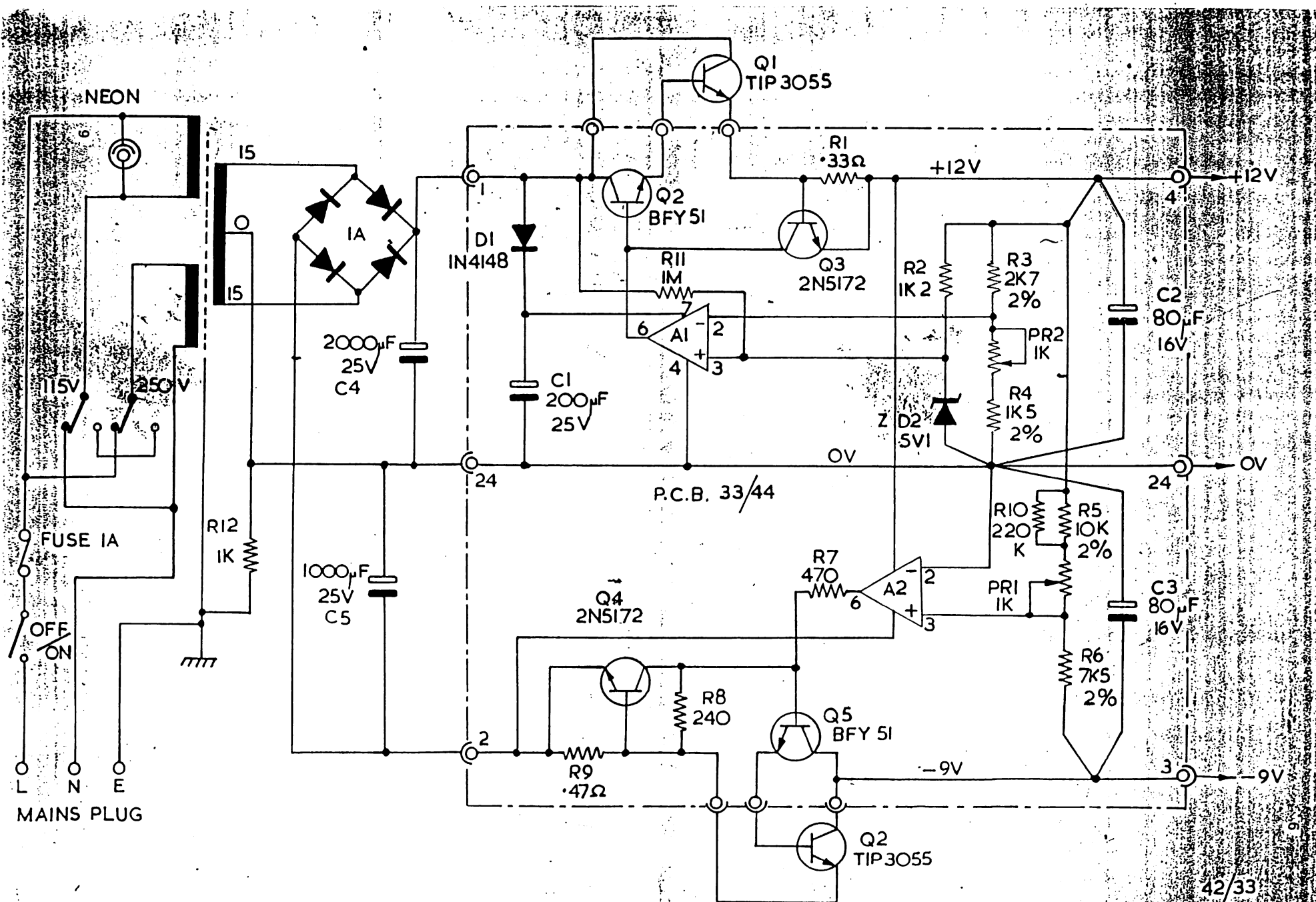

ALL 2N5172 NOW 13C169C

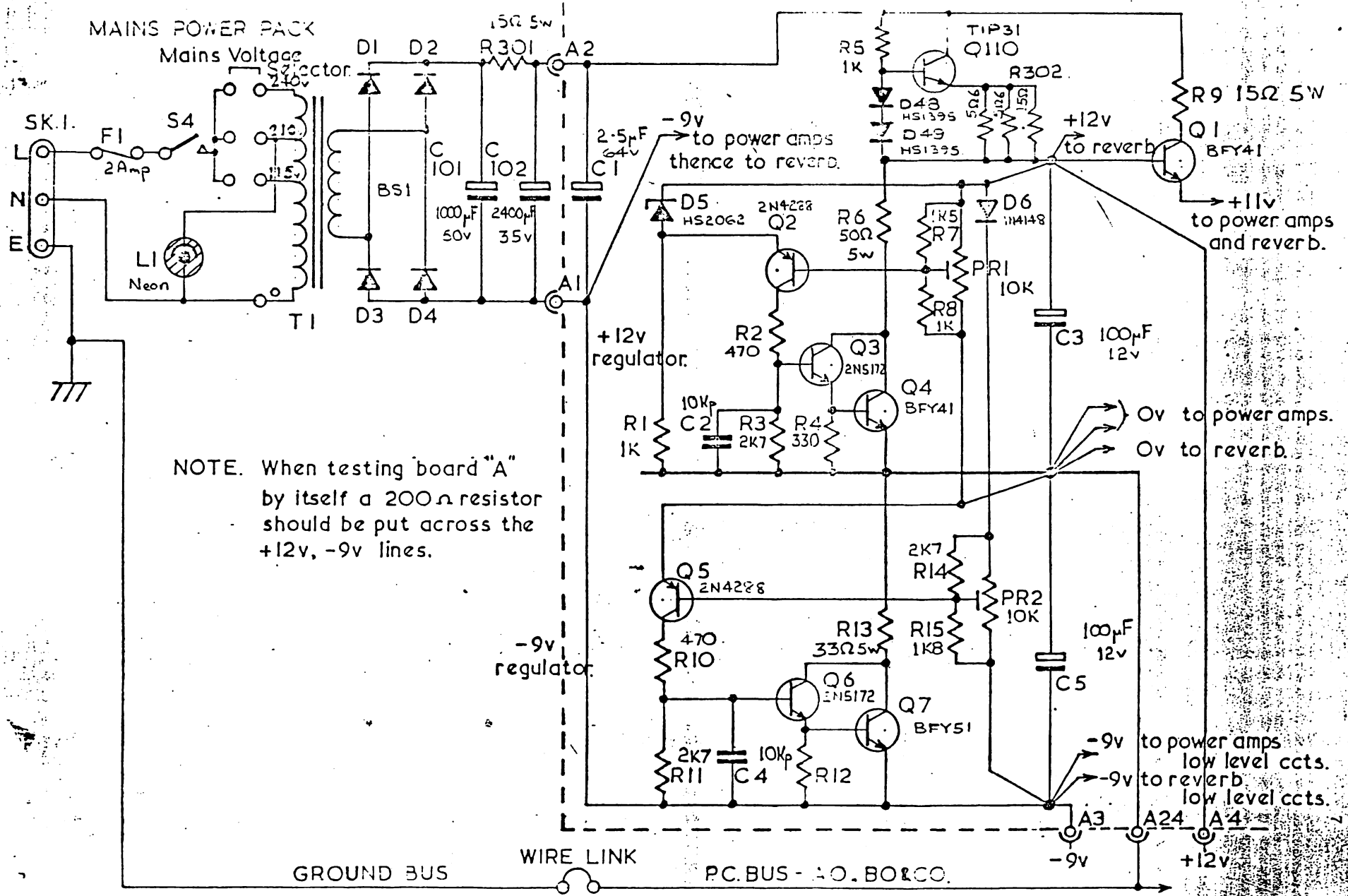

NOTE. When testing board "A" by itself a 200Ω resistor should be put across the +12v, -9v lines.

POWER SUPPLY P.C. BOARD A

Power Supply

Before turning on, set PR1 cw and PR2 ccw with only A board plugged-in.

Set PR2 for $+12V \pm 0.1V$

Set PR1 for $-9V \pm 0.1V$

Check PR2 again and reset if necessary

N.B. -9V rail is parasitic on the +12V supply.

Plug in B and C cards and recheck +12V and -9V rails.

These should not have altered. If they have, suspect either B or C board or poor regulation on A board. Plug-in keyboard as extra load. +12 and -9 Volt rails should not have moved more than $\pm 0.1V$ measured always on the A board. (C board voltage may be 20 mV lower)

Monitor the rails on the scope (5mV/cm). Look for hum and noise. These should be much less than 5mV. Noise, if present, will probably be due to the zener diode.

Power supplies should stabilise on full load for specified fluctuations.

110/240 nominal : +10% or -23%

110 nominal : 100V-135V for 125 sufficient

240 V nominal: 200V-260V

Hum can also be checked by the following:

Check Output Filters on 10

Output Controls on 10.0.10.10

Patchboard vacant

Monitor (5mV/cm) on signal output

Load unit with keyboard

100 Hz ripple as shown.

Noise can be seen which should never exceed 10mV p.p. Even with noise level up. With noise level down, the noise on this waveform should be quite low. Zener diode noise will be very obvious.

N.B. A2 normally gets hot, dodgy D1 gives large 100Hz ripple on Output.

Always clean edge-connectors and check clean presets on A board.

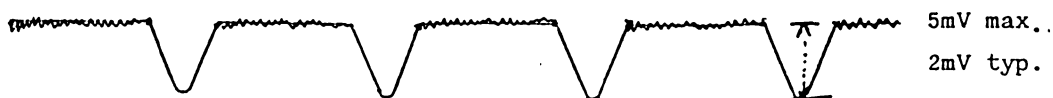

ALL 2N5172 NOW BC169C

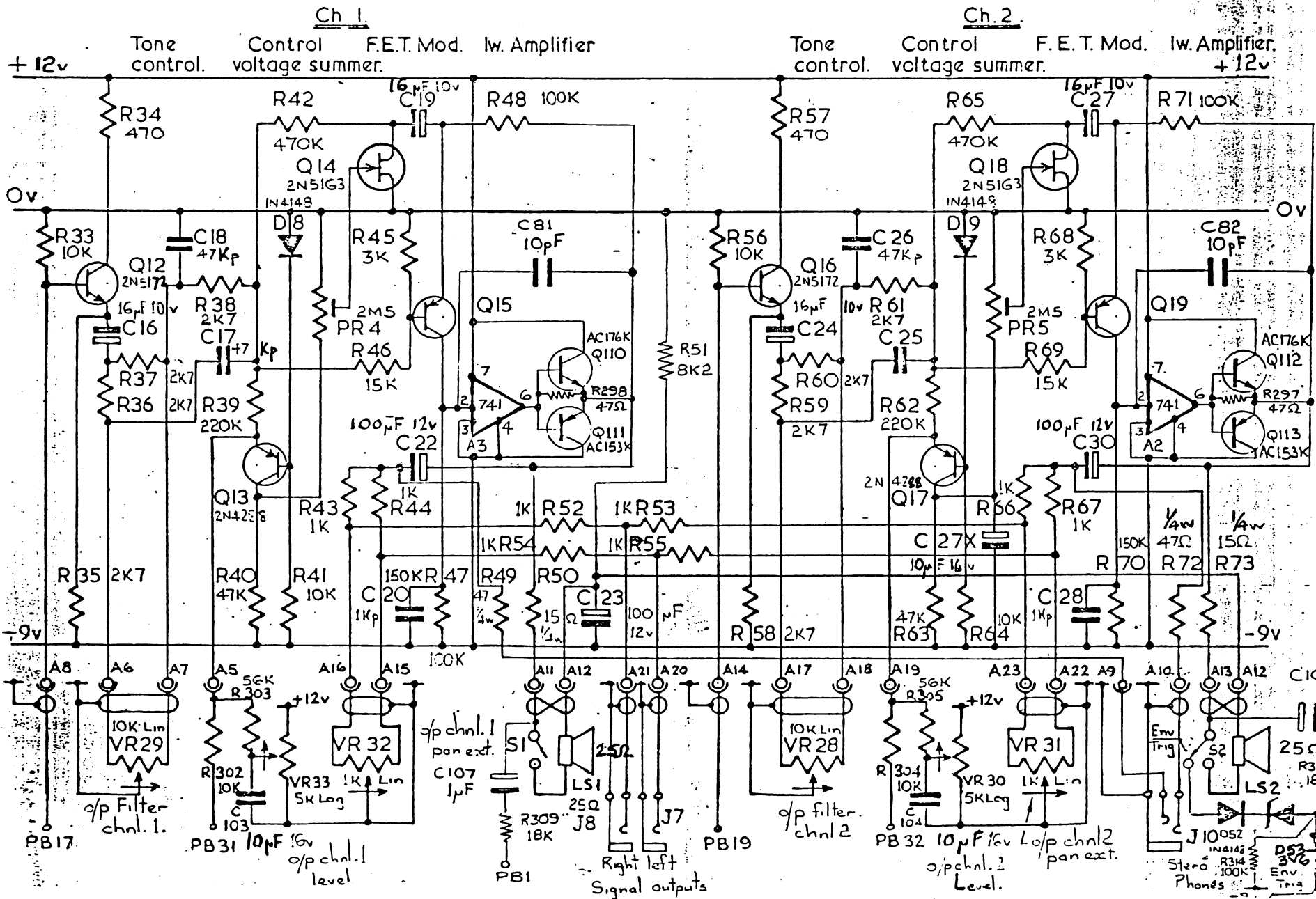

SOUND CHANNEL AMPLIFIERS & P.C. BOARD

Output Channels

Set Output Channel Filters to 5.

Set Output Level row to 0.0.10.0 and connect traces of scope (5mV/cm) to both signal outputs.

Connect full level ramp signal at 261 Hz from Oscillator 1 to both Outputs. Trim PR4 and PR5 for minimum signal breakthrough. (Maximum 5mv p.p) Replace presets if adjustment is erratic.

Reset Output Channel row controls to 5.0.10.5. Output levels should be around 1V p.p and should be within 20% of each other. Check signal tracking in the same manner for Output settings 4 and 6 as well. If one level is consistently high, pad out resistor across its control pot (R305 = 56K)

Successful tracking will depend on the characteristics of the pots and the correct matching of the FETs Q14 & Q18.

Connect the joystick row via two shorting pins to both VC level inputs. Swing stick up and down to check for 20% level tracking tolerance. (Level pots should be at zero). Inaccuracies in stick tracking may be adjusted by altering the value of R302 or R304 (10K) which are mounted under the patchboard rear.

Check correct operation of Pan controls, which only affect the Signal Outputs. Check also the Output Filters. Use noise as a good source.

Check for max. outputs on the Signal Output socket of at least 2.5V p.p before the onset of clipping. Level controls should be at about 6. Check headphone signal is good. Check for instability of Output Amps by driving hard with low frequency. (Oscillator 3 square wave). The level control of the channel NOT being driven should be on zero. Monitor the two signal outputs. The undriven channel will show breakthrough. Plug in headphones and check for oscillation. Reduce drive to Output Channel 2. Keep checking for oscillation. Then repeat for other Output Channel.

N.B. DC offset across loudspeaker is $1.8V \pm 10\%$.

Hi-Zo drive amplifier.

Pick-up amplifier & voltage controlled mixer.

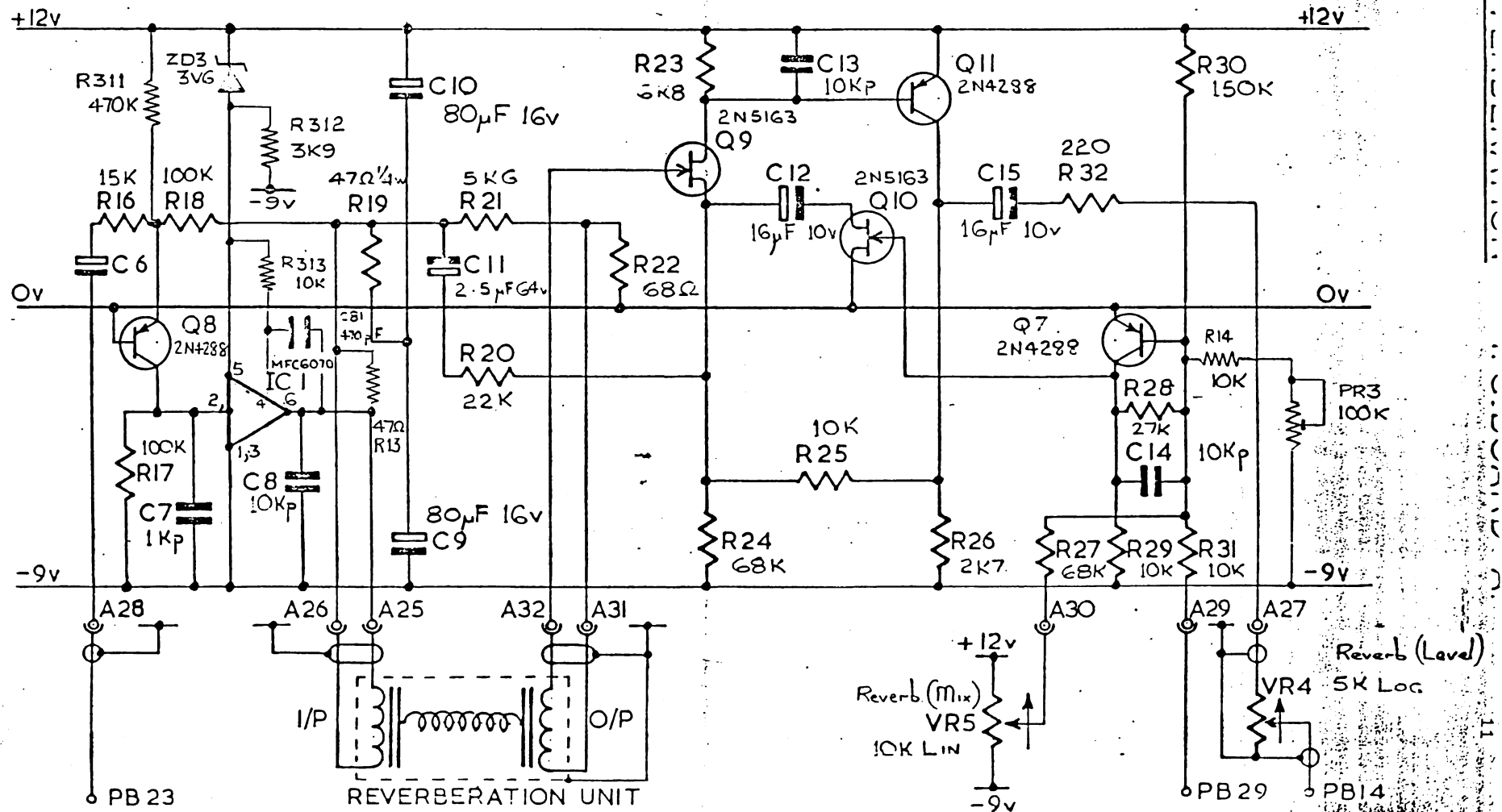

Reverberation

Set PR3 fully clockwise before operating. Feed large amplitude tone bursts into reverb. Adjust PR3 so that the output is dry at Mix setting of zero and reverberation progressively increases from setting of 2.

Maximum dryness on the Mix control should be no worse than that obtained with the VC Mix input row on the patchboard grounded.

Check voltage control of Mix with the joystick.

Hold input amplitude constant and sweep frequency of tone. Check for rattles, buzzes or abnormal resonances in the spring. Check spring is correct way round. If Mix control is wrong change Q10.

N.B. Reverb amplifier should clip symmetrically.

Q45 3.5-4.0 ALL 2N5172 NOW BC169C
 OR >1.5 ADJUST R143

Q48
 $V_p = 2.5 - 3.0$

THRESHOLD SET

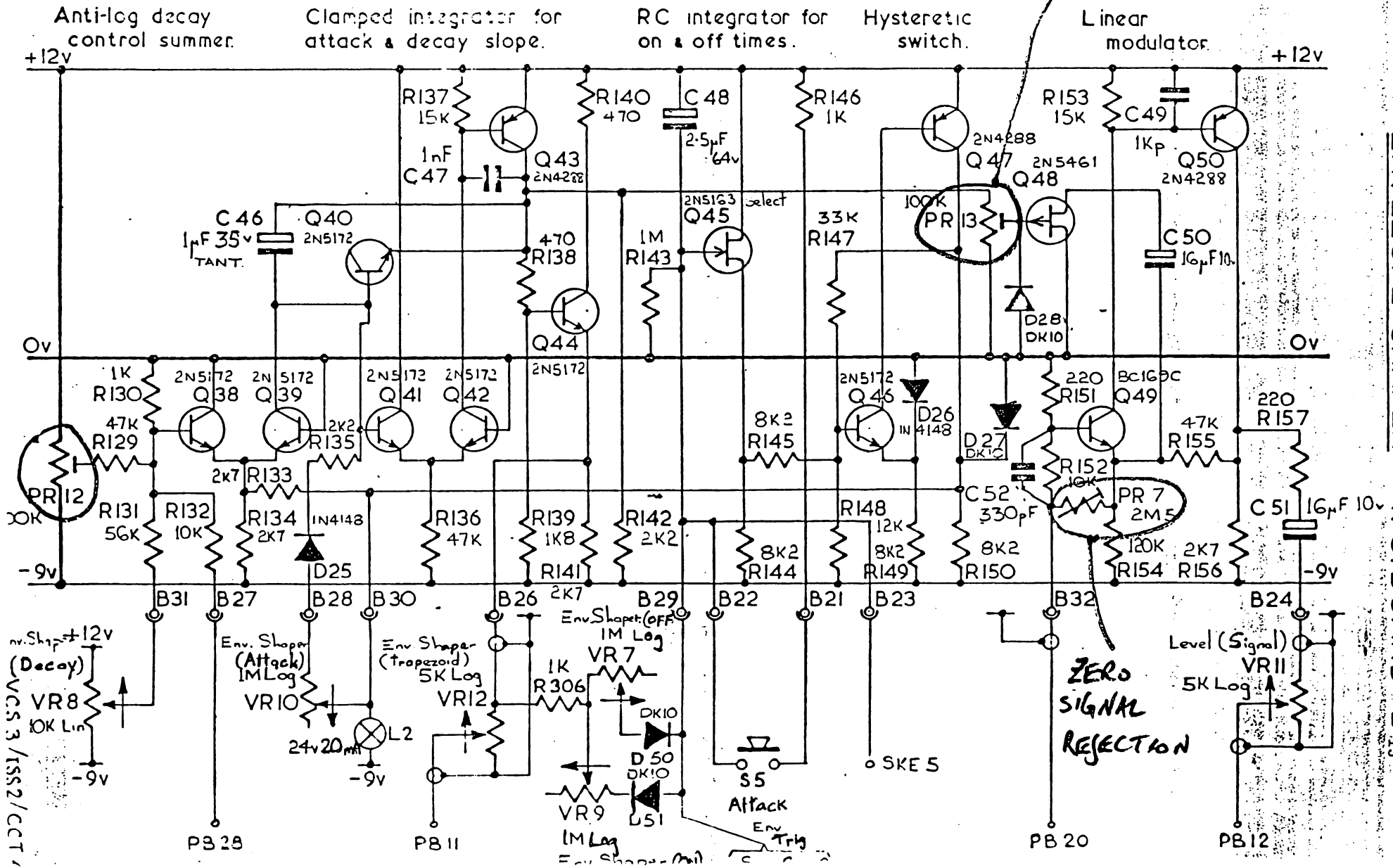

vr. Shp. +12v (Decay)
 VR8 10K Lin
 -9v
 VCS 3 / ISS2 / CCT

Env. Shaper (Attack) 1M Log
 VR10
 24v 20mA
 -9v
 PB 28

Env. Shaper (trapezoid) 5K Log
 VR12
 PB 11

Env. Shaper (OFF) 1M Log
 VR7
 1K R306
 D50 DK10
 VR9
 1M Log
 Env. Shaper (on)
 PB 12

Attack Env Trh
 S5
 PB 20

ZERO SIGNAL REJECTION
 PB 20

Level (Signal) VR11 5K Log
 PB 12

Envelope Shaper

Put scope on 2V/cm and connect to Trapezoid output. With envelope controls at 0.0.0.0. Adjust PR12 so that frequency of trapezoid oscillation is about 90% of the maximum possible frequency. Connect Filter output on 261 Hz (Frequency setting 5) with maximum output to Envelope Input. Monitor Envelope output. Set PR13 clockwise.

Set envelope controls 0.0.0.10. Adjust PR7 for minimum signal. Adjust PR13 until signal reappears, then back off slightly. The final envelope shaper signal breakthrough should be 5 mV or less p.p. With the Attack button pressed the output signal should be greater or the same as the input signal.

Set controls 0.10.0.10. this gives maximum On time. Press Attack button which should recycle the envelope shaper and lamp should come On, staying on for about 5 seconds. (absolute minimum 4 seconds). This corresponds to an automatic recycle On time of 2.5 seconds which is the minimum spec. (On time is always shorter if recycled automatically). On time is controlled by R148 in conjunction with Q45. f ' ,

Set controls 0.0.10.5. Press Attack button and time the Decay time. This should exceed 15 seconds, and the envelope shaper must automatically recycle at the end of the decay.

Set controls 0.0.0.7 to 10. Envelope shaper must not recycle with the Off time on 10, so check it doesn't on 7 or so, which will indicate the behaviour on 10. Check input breakthrough at the same time, and adjust PR7 again if necessary.

On and Off times are controlled by R148 (range 10-18K). If On time is infinite at 10, reduce R148, if Off time infinite, increase R148. The value of Vp for Q45 (3.5 - 4.0 nominal) is critical. Failure here upsets recycling. Also leaky C48 or dodgy envelope trigger components .

ALL 2N5172 100V 100Ω

Q26 2.5-3.5
(OR > 1.5 AND ADJUST R89)

2.5-3.0 RED
3.5-4.0 ORANGE

Antilog freq. control summer. Ladder filter Signal phase splitter. F.E.T. feedback control. Differential signal amplifier.

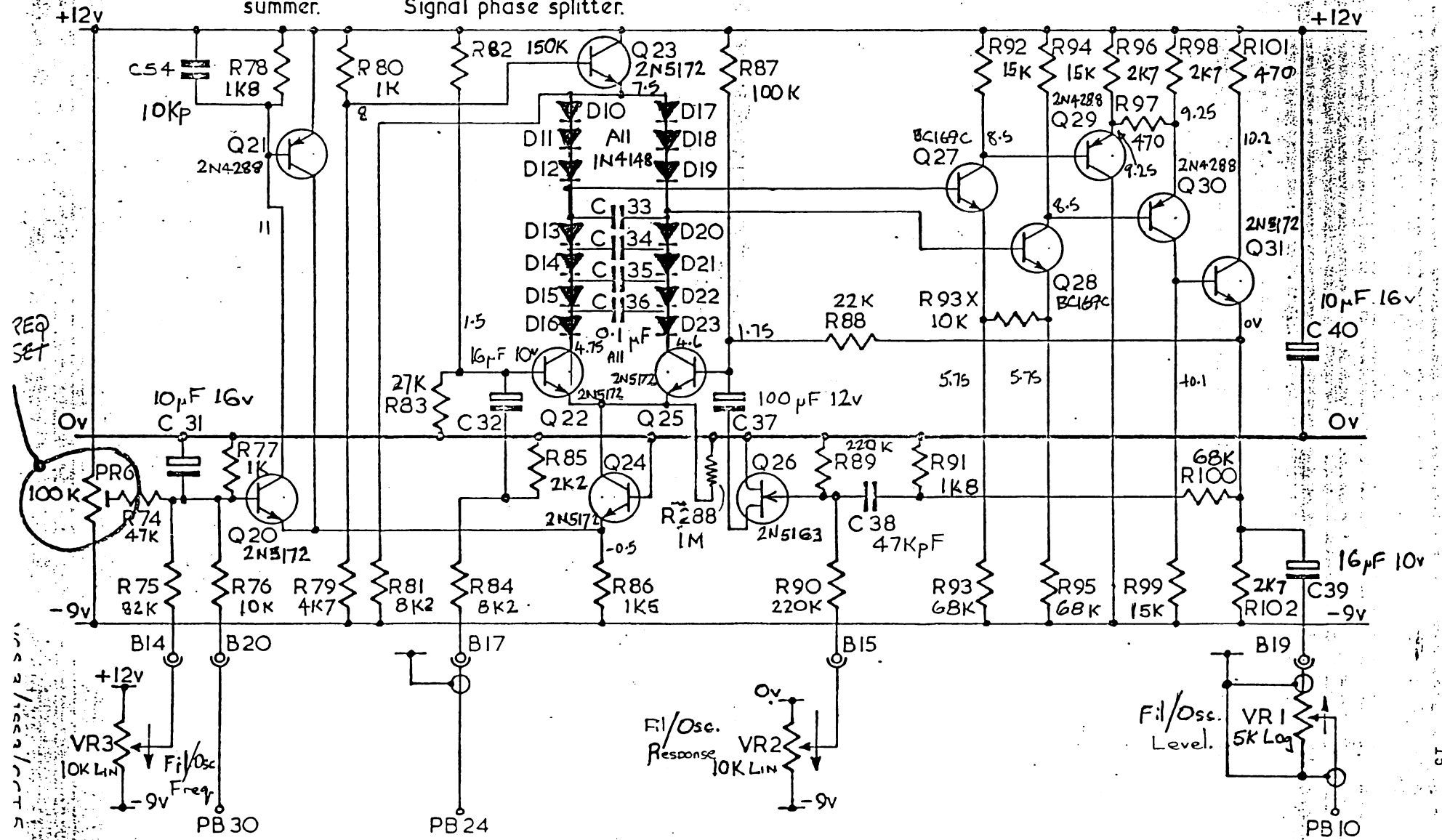

RED SET

VR3 10K LIN PB30

F1/Osc. Response VR2 10K LIN PB24

Fil/Osc. Level. VR1 5K Log PB10

VOLTAGES MEASURED @ OSC 250c/s Av 25V D.C.

Filter/Oscillator

With Response on 10, level full and Frequency on 5, check for oscillation. About 1.5V p.p should be obtained. The shape should be reasonably sinusoidal especially when only just oscillating (on Response control).

Distortion should be eliminated either by diode bridging or by replacement of offending diode. Bad diodes can be detected by applying the tip of a soldering iron quickly to the diode body. Allow enough time for the diode to cool down before moving on to the next one.

Response control should make the filter oscillate only above 5 for all frequency settings. If this does not occur correctly, adjust R90 or suspect wrong Vp FET. Frequency range on the Frequency knob should be roughly 10Hz to 12kHz. If oscillations stop at one extremity of Frequency pot increase R75. Adjust PR6 for oscillation frequency of 261Hz with F on 5. Noise level of Filter output signal with Response set below point of Osc should be below 5mV p.p.

Check correct filtering using square wave input with swept F.

Intermittent noise: Try soldering iron tip on diodes.
R288 = 1 megohm stops Filter latching-up.

Double balanced modulator

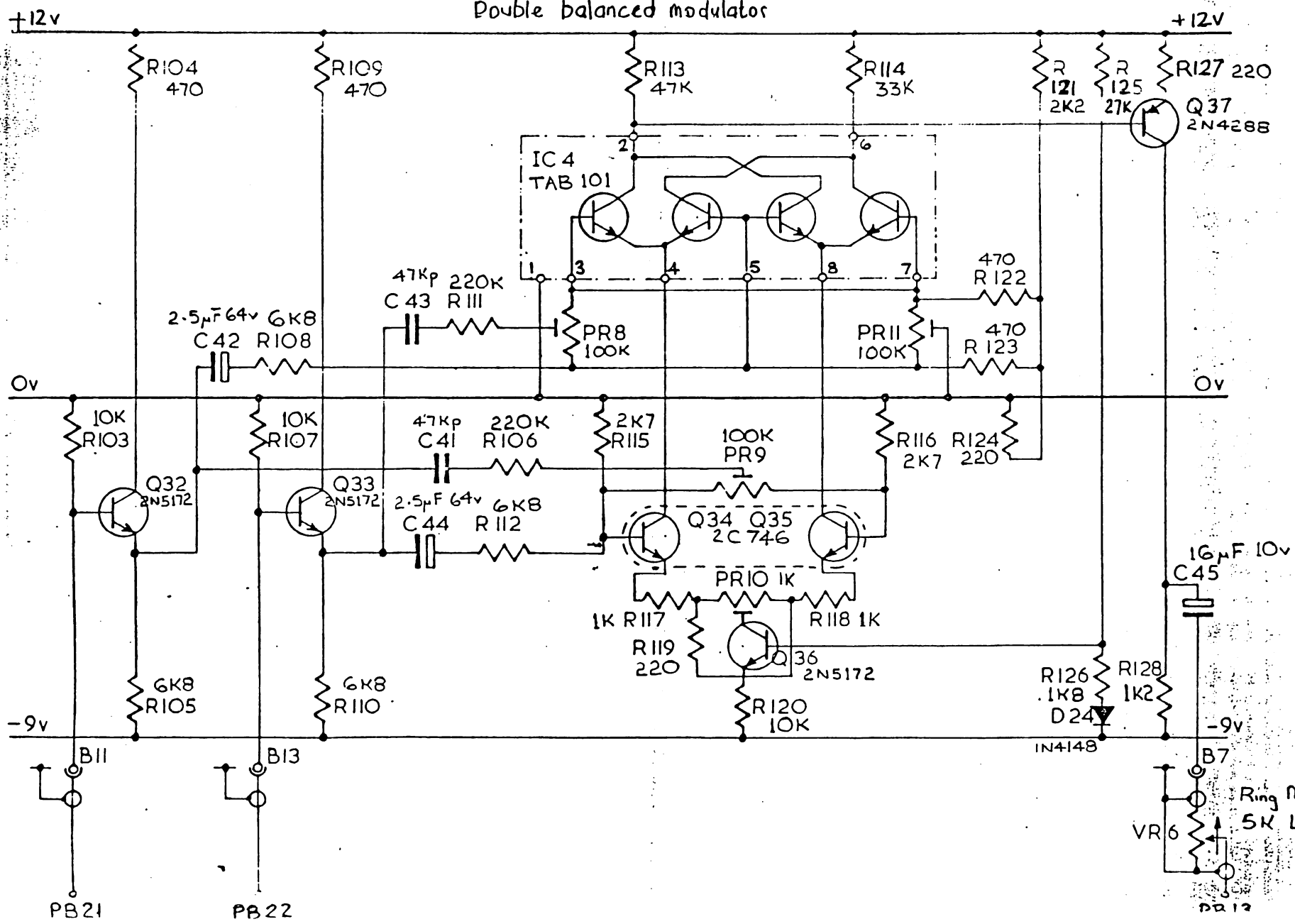

Ring Modulator

Use filter sinewave output, F on 5. Maximum response, maximum level into both inputs of ring modulator. Ring Modulator level maximum. Check output is double frequency of input, and at least as big. Remove pin to Input B. Drive input A and adjust presets for minimum breakthrough. (PR9 - second harmonic rejection, PR10 - fundamental rejection).

Drive Input B by removing pin to Input A and reinserting pin for input B. Trim presets for rejection. (PR8 - second harmonic, PR11 for fundamental). This one should NOT drift. Input A drifts quite a bit and should ideally be adjusted with the back on the machine after it has fully warmed-up. If this is not possible ensure that Input B is used for the continuous signal to minimise breakthrough.

With an input level of 1.5V p.p up to 10mV p.p maximum is allowed for breakthrough. This gives about 60 dB rejection.

If higher harmonics are a problem, then filter signal must be too impure. Try backing off response, or use an external signal generator. 1.5V p.p at 261 Hz.

If reasonable rejection is unobtainable, change matched pair BC169C or TAB101 where appropriate. 2C746 used on later models. Do not bridge with resistors. Replace presets if adjustment is erratic.

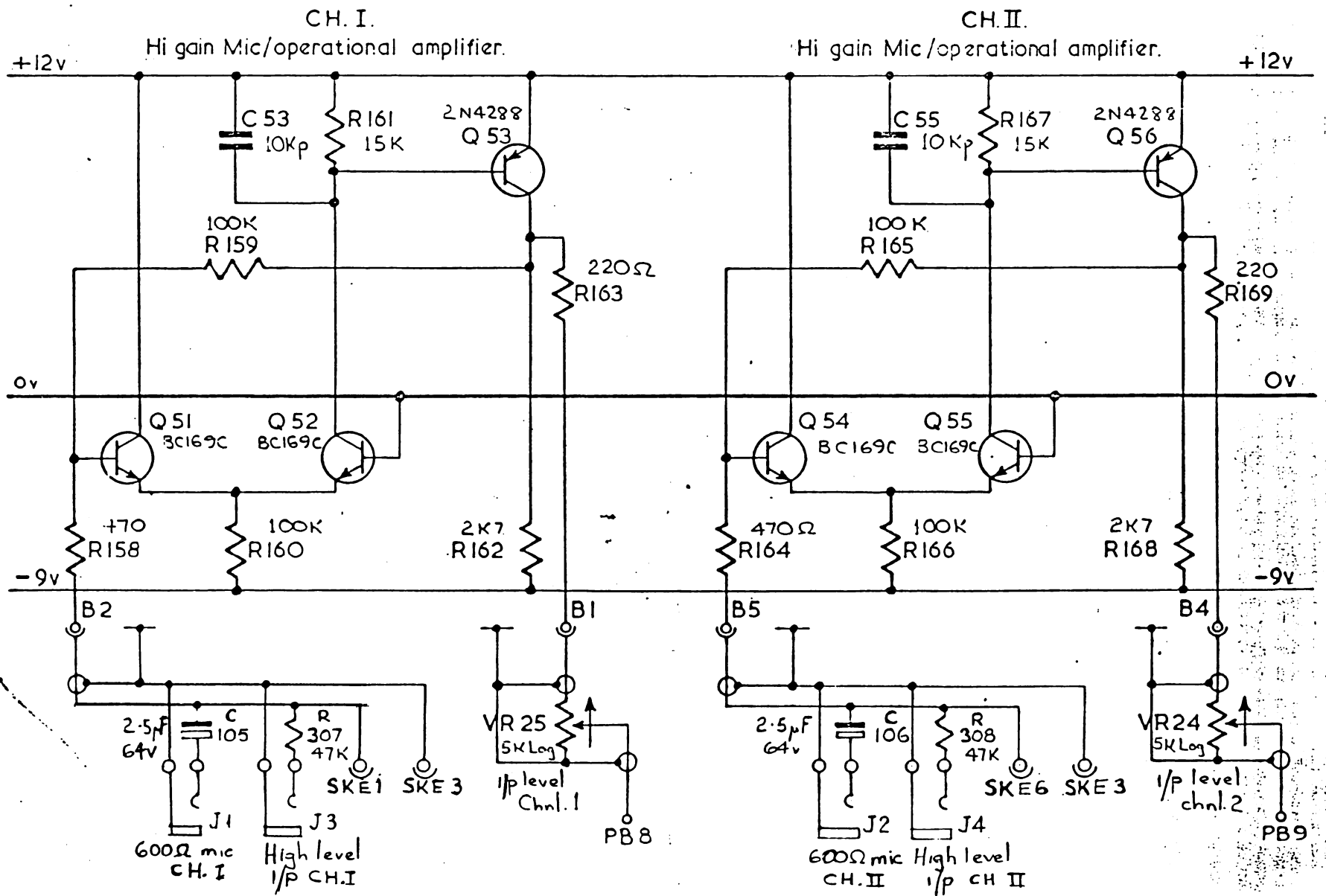

VCS 1 1957 CCT 7

Input Channel Amplifiers

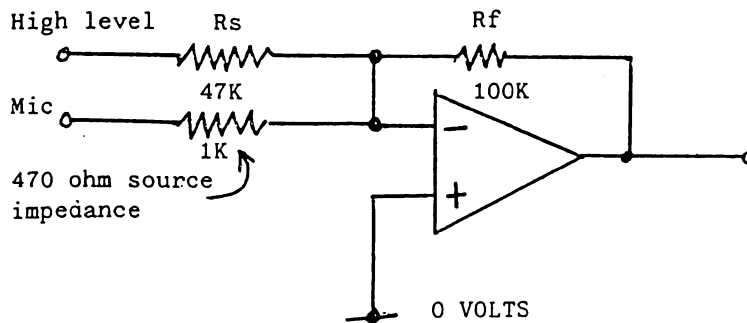

Inverting Operational amplifier

$$\text{DC gain} = \frac{R_f}{R_s}$$

$$\text{High level gain} = 2$$

$$\text{Microphone gain} = 100$$

Using a signal generator check the two inputs for the expected gains. This is best done by monitoring the control output with shorting pin. High level gain can be checked by applying about 2V p.p and looking for 4V at the output.

Low level (microphone) gain : 50mV should give 5V p.p.

Check for minimal DC offset by plugging input channel inot the meter switched to Control Voltages, and then rotating the input level pot. No more than $\pm \frac{1}{2}$ a division movement should occur. (approx 200mV).

Pay special attention to condition of pot tracks.

4-4-65 72 100 100 100

antilog frequency control summer Ramp integrator Hysteretic switch Triang to sine shaper

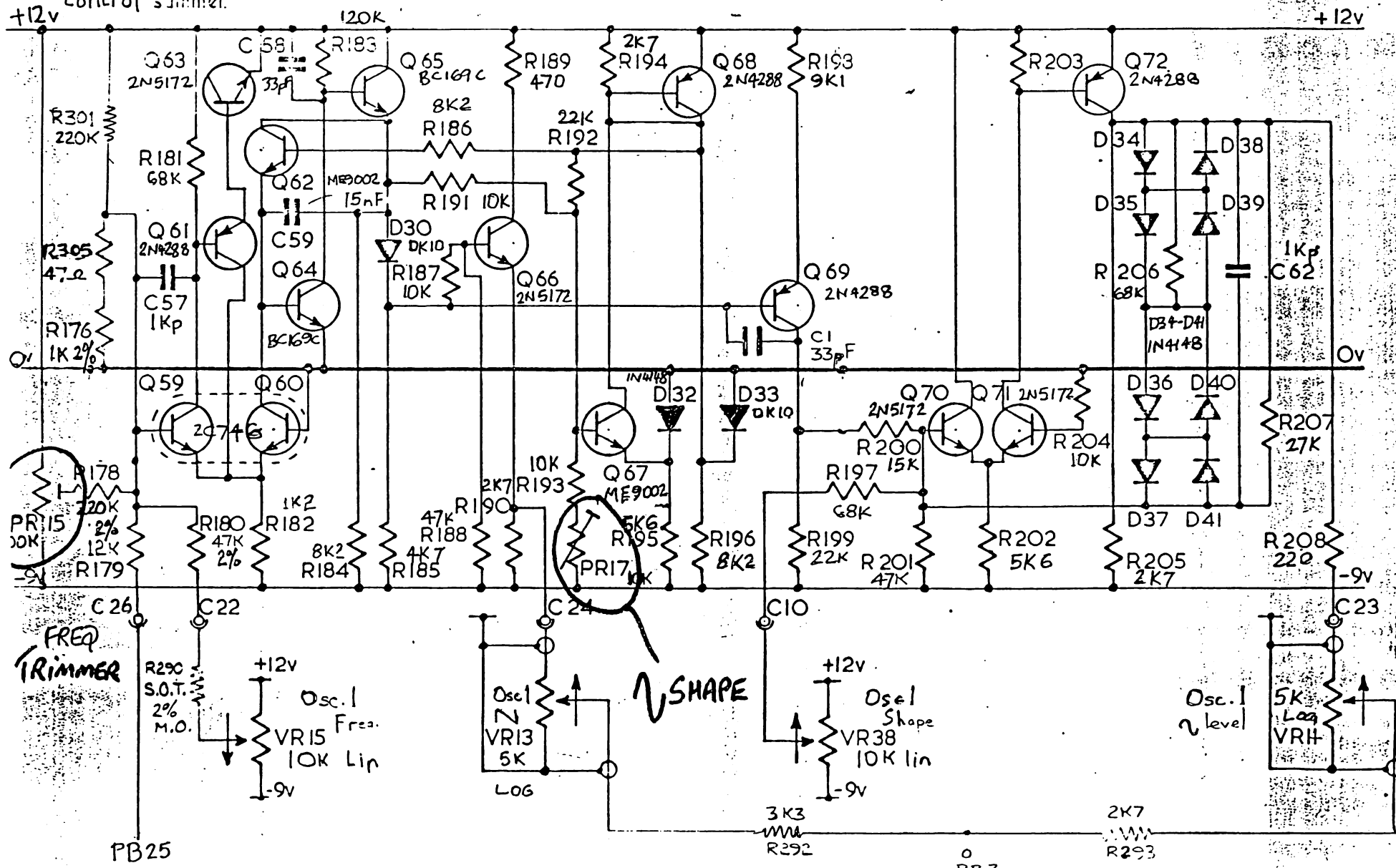

Oscillator 1

The first operation is to adjust the shape of the sinewave, since the adjustment affects frequency. Using the vernier control and PR15 if necessary, obtain an output of 400Hz. Turn the ramp down and adjust the sine shape control for the best sine shape. Trim PR17 to balance out the spike on the peak of the sinewave. This may best be seen by expanding the X and Y inputs on the scope.



The best position is shown, where the small spike is triangular and balanced. A small thin spike may also appear but is not important.

Test the main shape control. A good sinewave should be achieved on 5. ($\pm \frac{1}{2}$ division). If further out, R197 or R201 may need to be adjusted.

Set PR16 halfway and leave it alone. Set frequency vernier dial to 6 and adjust PR15 for 261Hz. Rotate vernier to 8 and check for 2088Hz. Absolute maximum error ± 1 division. For fudge procedure, see Osc 2 writeup.

Sine Output should be around 1.5V p.p

Ramp Output should be around 1.5V p.p

N.B. Ramp shape is not controllable.

Pitch characteristic is 0.32 Volts/Octave.

ALL 2N5172 NOV 30 1960

PC27 was 13K
NOV. 2. 8. 72

OSCILLATOR 2

P.C. BOARD C.

25

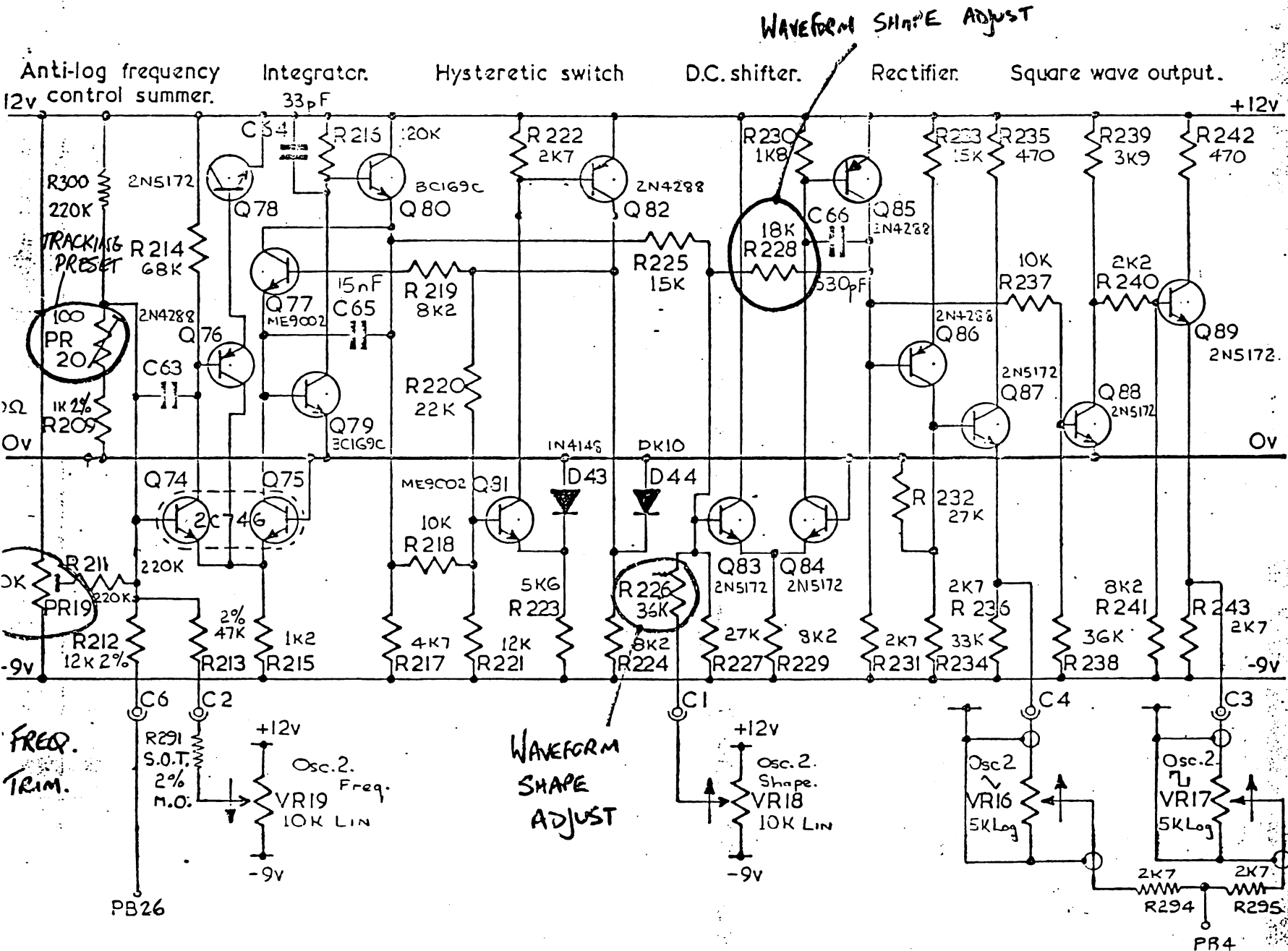

FREQ. TRIM.

WAVEFORM SHAPE ADJUST

WAVEFORM SHAPE ADJUST

Anti-log frequency 12v control summer. Integrator. Hystzretic switch. D.C. shifter. Rectifier. Square wave output.

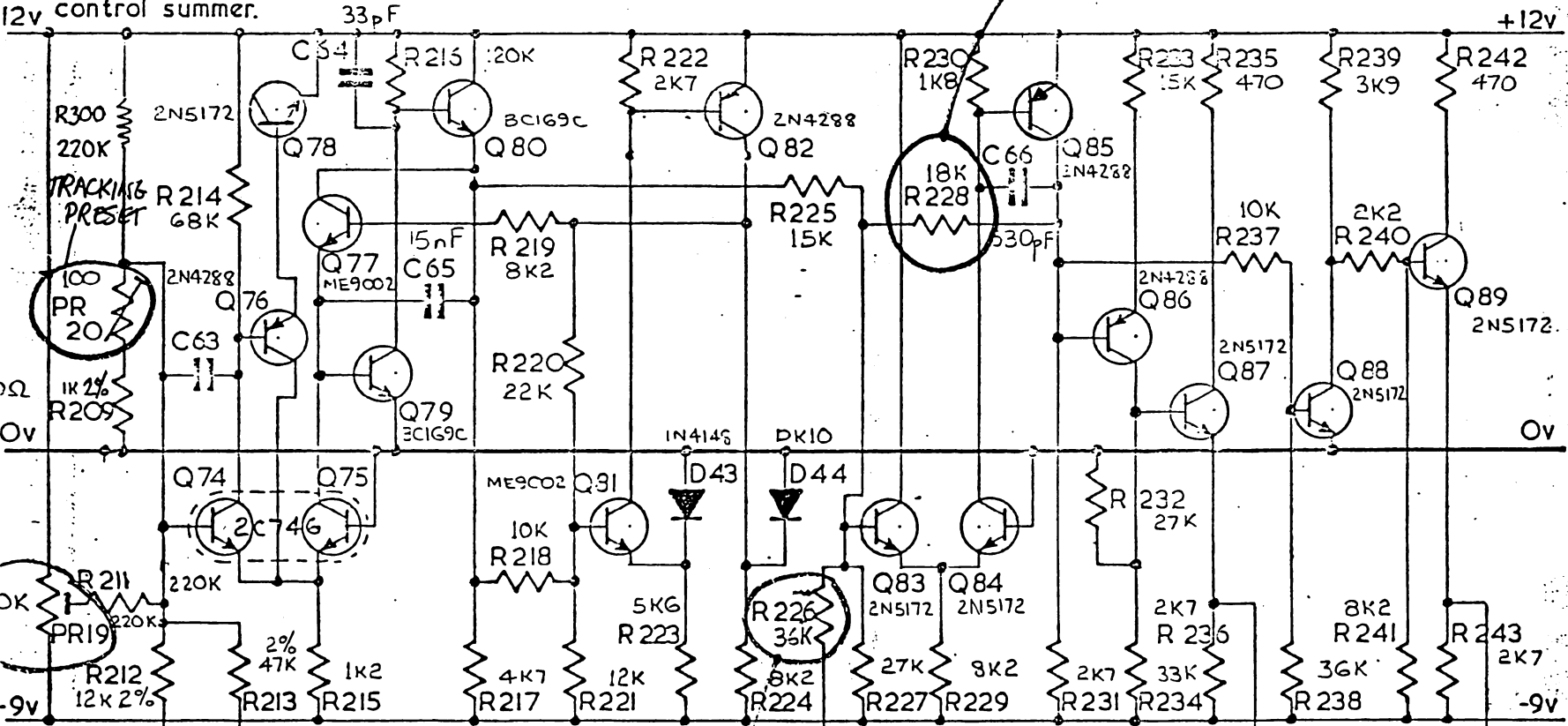

PB26

PB4

Oscillator 2

Set square level to zero, ramp at maximum. Set PR20 halfway. Vernier on 6. Trim PR19 for 261Hz. Increase vernier to 8. Check frequency is about 2088Hz. If beyond spec then R291 SOT will have to be added in the range 8-22K. Check that 10 on vernier dial gives at least 10kHz. If vernier dial at 8 gives less than 2088Hz then short circuit R291 and R213 will have to be reduced. These should be 2% resistors. Shape controls should operate identically to those on Osc 3 (see next page) except that levels are reduced, and the two outputs are summed into the patchboard on Mark 11 machines. Remember to turn down unwanted signal. Resistors R226 and R228 are the relevant ones to set the shape. Pulse level should be 2V p.p. Ramp level should be 3.5V. N.B. Osc2 and 3 waveforms are not symmetrical with respect to zero volts.

Tracking

Mix Osc 1 and Osc 2 ramp outputs into Output Channel 1. Use PR20 only to trim the tracking of Osc 1 and Osc 2. Using the joystick on max with range control to limit frequency range. Set both verniers to 6 and tune for zero beats. Advance the joystick range control which will increase both frequencies until the beats begin. Trim PR20 to zero beats, and remember which way you turned it. (N.B. The preset is a very fine adjustment, and when the tracking is nearly right it will be necessary to make very very small movements). Having trimmed PR20, turn the range control back to zero, readjust one of the verniers near 6 to give zero beats and then advance range control of joystick to where it was before. If beats are faster you know you turned the preset the wrong way. Repeat procedure until tracking goes to about 2kHz. Ideally a test 'back' should now be fitted and a final adjustment made after another 10 minutes have elapsed.

Faults

Tracking from 261Hz to about 2kHz should be achieved with a maximum of 3 beats per second on the way. A curved Voltage/Frequency response may occur where zero beats are produced in more than one place. This is due to a mismatch in the matched pair transistors (Q74 & Q75 for Osc 2). Fit a new transistor here or in Osc 1.

N.B. Always use specially matched 2K7 pins for tracking tests.

ALL 2N5172 100V BC169C

WAVEFORM SHAPE ADJUST

• Anti-log frequency control summer. Integrator. Hysteric switch D.C. shifter. Rectifier. Square wave output.

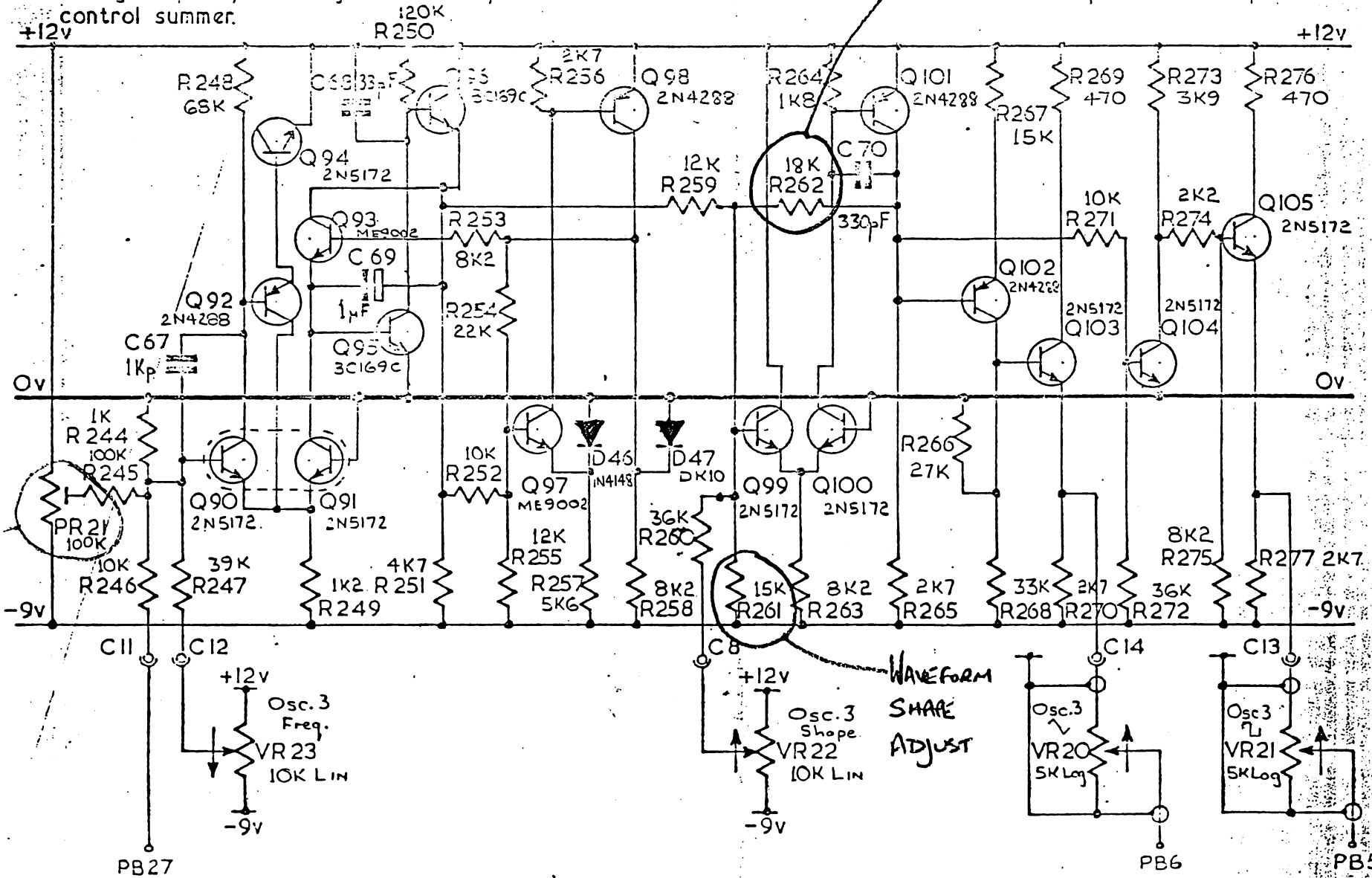

OSCILLATOR BOARD

Oscillator 3

Check frequency control pot for even change in frequency.

Adjust PR21 so that when the vernier is at 8 the frequency is 63Hz.

Note: Vernier 10 should give 500Hz. Period at 0 should be greater than 20 sec.

Adjust values of R261 & R262 with pad resistors to achieve correct shapes of waveforms as shown below:

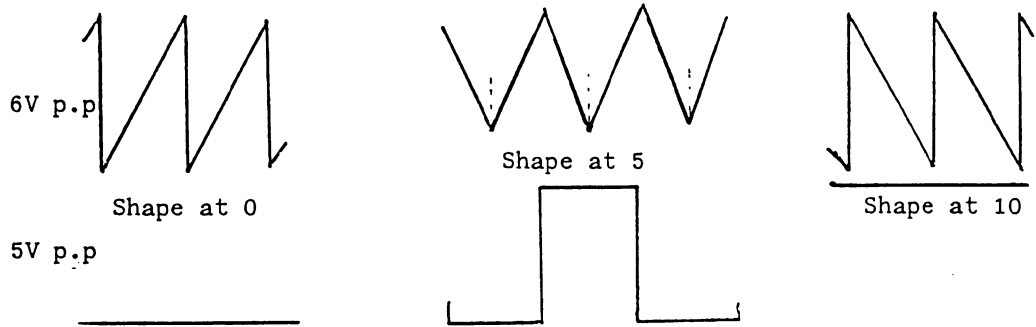

Triangle and square wave should occur on 5. Maximum of 1/2 division error allowed.

Check Voltage control input.

Faults

Osc 3 breaks through to Osc 2 and to a lesser extent Osc 1. Effect dependent on Osc 3 shape control setting. Triangle was 'furry', with 10mHz oscillations visible all over C board. Strongest near Q101. Cause: instability in Q99, Q100, Q101. Cure, C70 330pF change to 1nF.

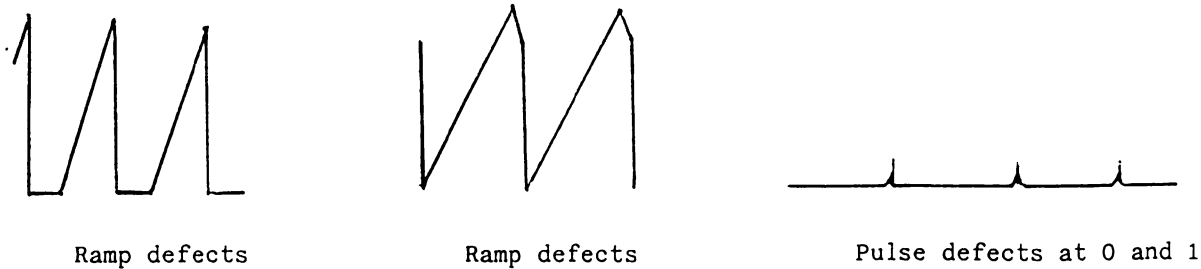

11-11-72 NOW EC-60C

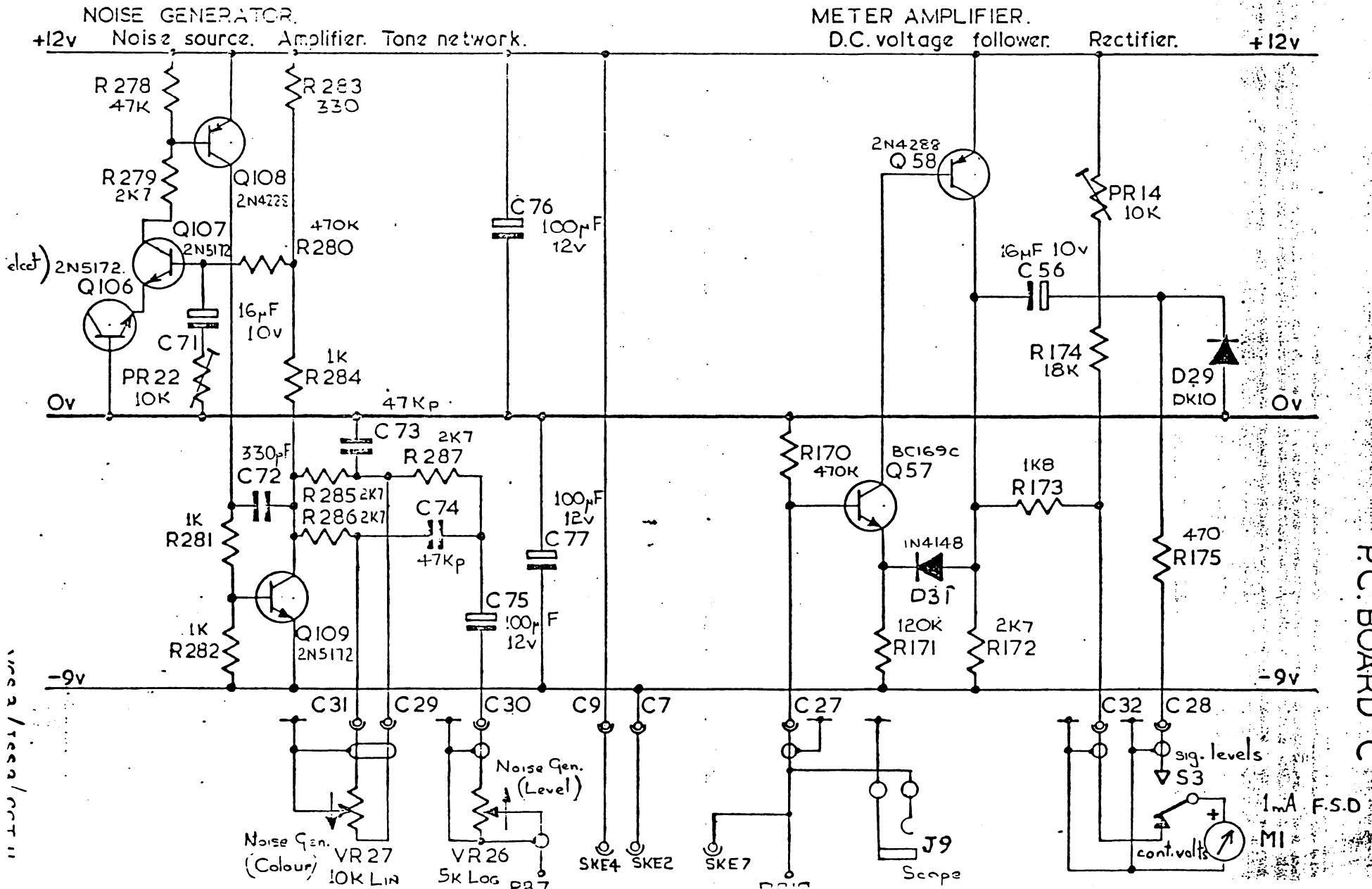

Noise Generator & Meter Amplifier

Colour control on 5, max output. Select a noise diode which gives wideband noise and can be adjusted to give 3V p.p with PR22 roughly midway (to give some later adjustment margin).

Lumpy or crackly sounding noise diodes should be rejected.

Meter

Check left hand zero of meter with machine off or switched to Signals.

Switch to Control Voltages and adjust PR14 for accurate centre zero.

Switch the meter switch a few times and recheck zero again.

Patch the joystick to Meter for swings in both + and - directions.

Check for needle sticking at either end of travel. Switch to Signals and test with Osc 2 sawtooth at max level. Vary level to check proportionality.

Faults

Watch out for the resistor R170 on the C board, which often touches the -ve end of C76, and has been known to produce curious failures on soak test.

NOTE! Q14 & Q18 MATCHED FOR V_p & I_{oss}

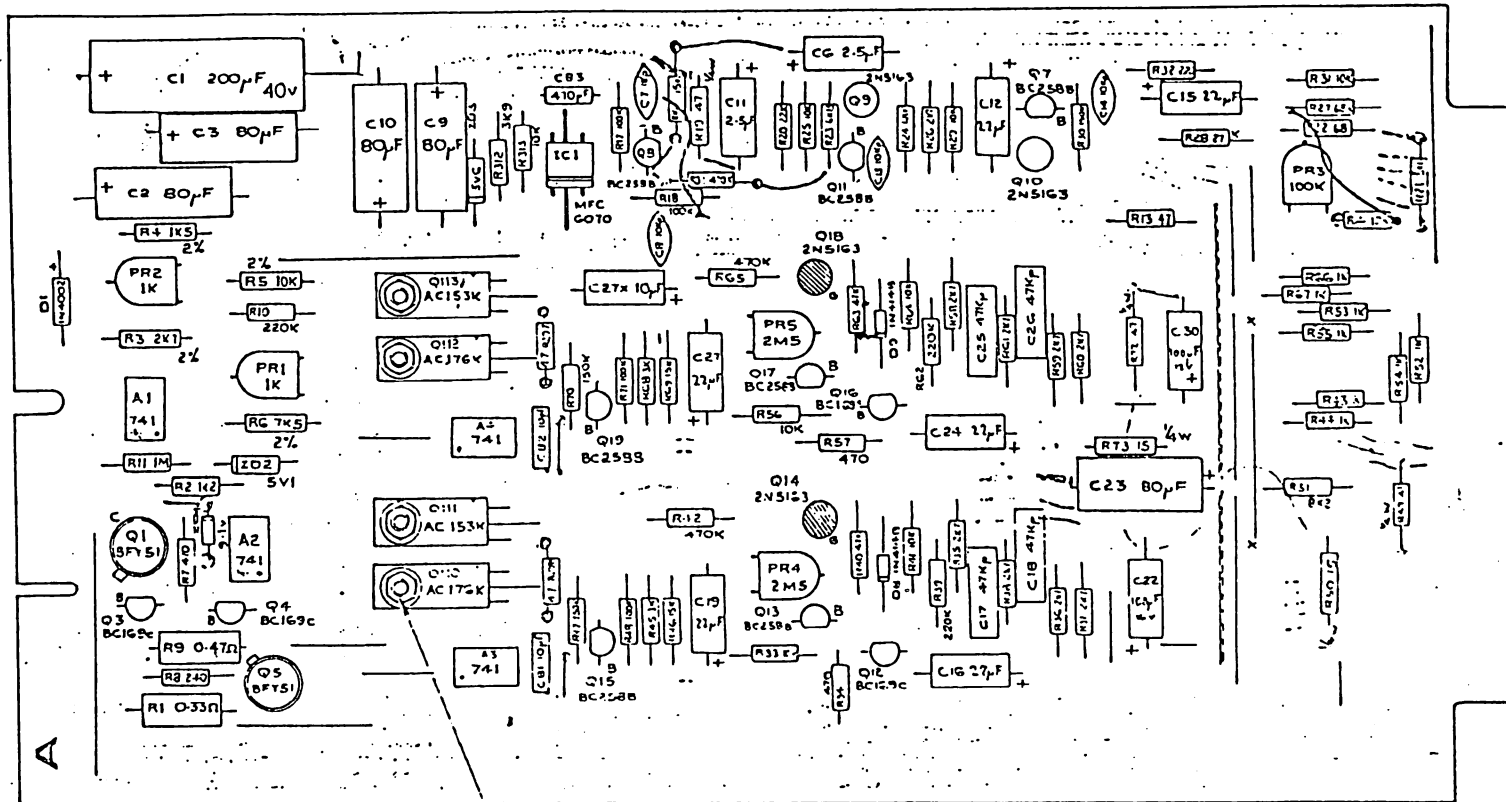

TIP3055
Q2
Q3
Q4
Q5
Q6
Q7
Q8
Q9
Q10
Q11
Q12
Q13
Q14
Q15
Q16
Q17
Q18
Q19
Q20
Q21
Q22
Q23
Q24
Q25
Q26
Q27
Q28
Q29
Q30
Q31
Q32
Q33
Q34
Q35
Q36
Q37
Q38
Q39
Q40
Q41
Q42
Q43
Q44
Q45
Q46
Q47
Q48
Q49
Q50
Q51
Q52
Q53
Q54
Q55
Q56
Q57
Q58
Q59
Q60
Q61
Q62
Q63
Q64
Q65
Q66
Q67
Q68
Q69
Q70
Q71
Q72
Q73
Q74
Q75
Q76
Q77
Q78
Q79
Q80
Q81
Q82
Q83
Q84
Q85
Q86
Q87
Q88
Q89
Q90
Q91
Q92
Q93
Q94
Q95
Q96
Q97
Q98
Q99
Q100

Mounting Points to be used on Q1 & Q5 TO5 type.

4x GBA - 1/2 C.W (G-SIM) - FULL NUT & 5 PROOF

- 32 > Reverse n/p
- 31 VR5 (w)
- 30 PB5
- 29 PB5
- 28 PB23
- 27 VR1
- 26 > Reverse j/p
- 25 OY
- 24 VR31
- 23 VR31
- 22 VR31
- 21 J7 (F)
- 20 J7
- 19 PB32
- 18 VR28
- 17 VR28
- 16 VR32
- 15 VR32
- 14 PB19
- 13 LS2
- 12 LS14 LS2
- 11 LS1
- 10 J10R
- 9 J10T
- 8 PB18
- 7 VR27
- 6 VR27
- 5 PB31
- 4 +12V OUT
- 3 -2V OUT
- 2 -D.C. IN
- 1 +D.C. IN

- G. C.V. 82, R. 1.8 33
- F. NOTES 1.5 1.5 1.5 1.5 1.5
- E. C.N. 23 Ec. 2.4 97
- C.N. 44
- D. C.N. 33 Ec. 5.2 77
- C. P. 0.2 7.1 1.2

* A: 1/2 INCHES FROM PERIPHERY

- NOTE: 1. C1 SHOWN AS 25V ON BOARD
 2. R34 VALUE I.E. 470 NOT SHOWN ON BOARD
 3. LINK BETWEEN POINTS X & Y NOT SHOWN ON BOARD.
 4. P04 NOT SHOWN ON C.W.
 5. C7, 13, 16, 17, 22, 24, 27, 30 SHOWN AS µF ON BOARD.

HILTON ELECT. CO.
 WASHINGTON, D.C.

TITLE
 A BOARD
 SYNTH. ASSY.

REV.	DATE	BY	CHKD.

4-3-77

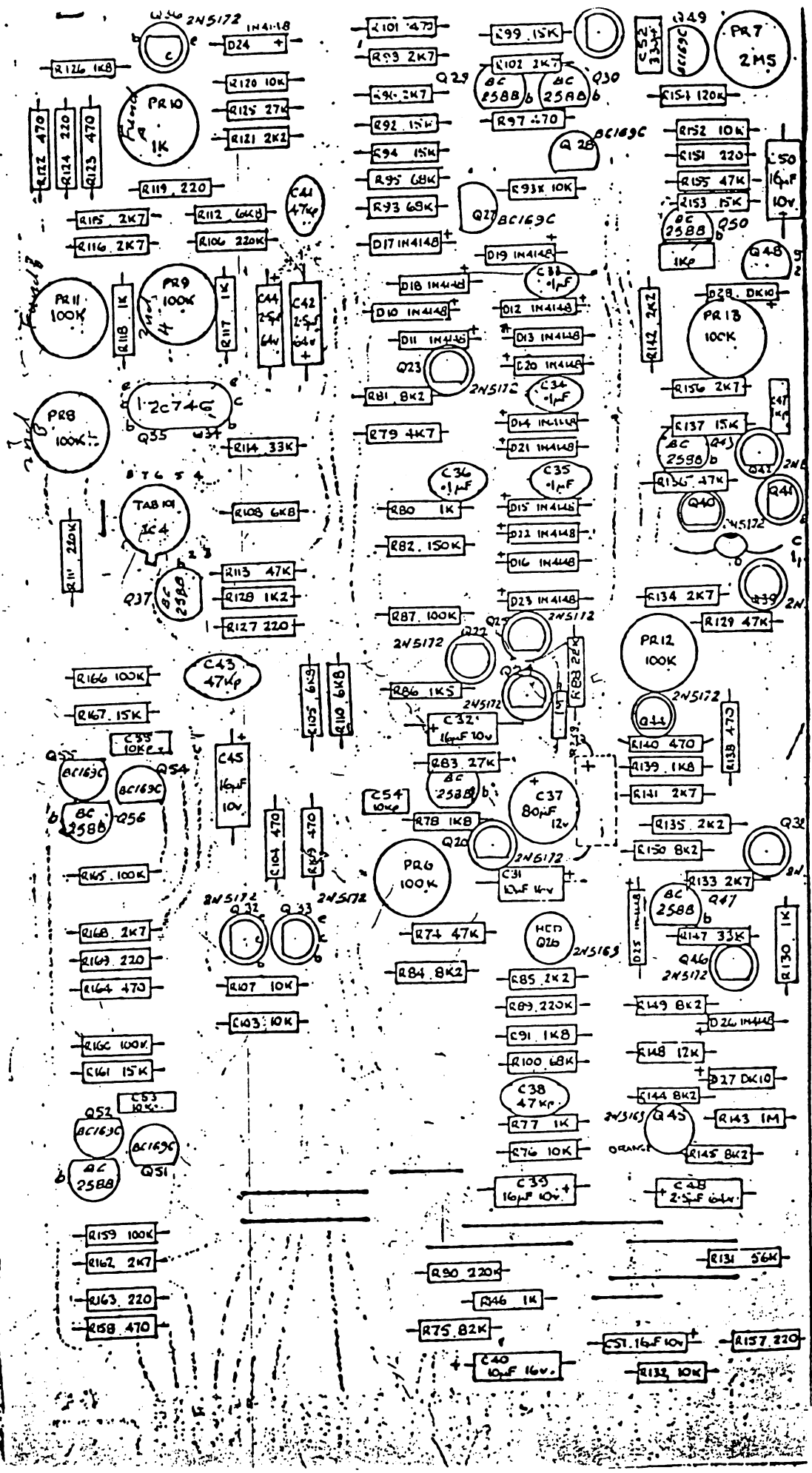

This document set is the property of Electro-Music Studios (London), Ltd. and the information therein has been made available on the condition that it remains confidential and is not disclosed to any other person or company.

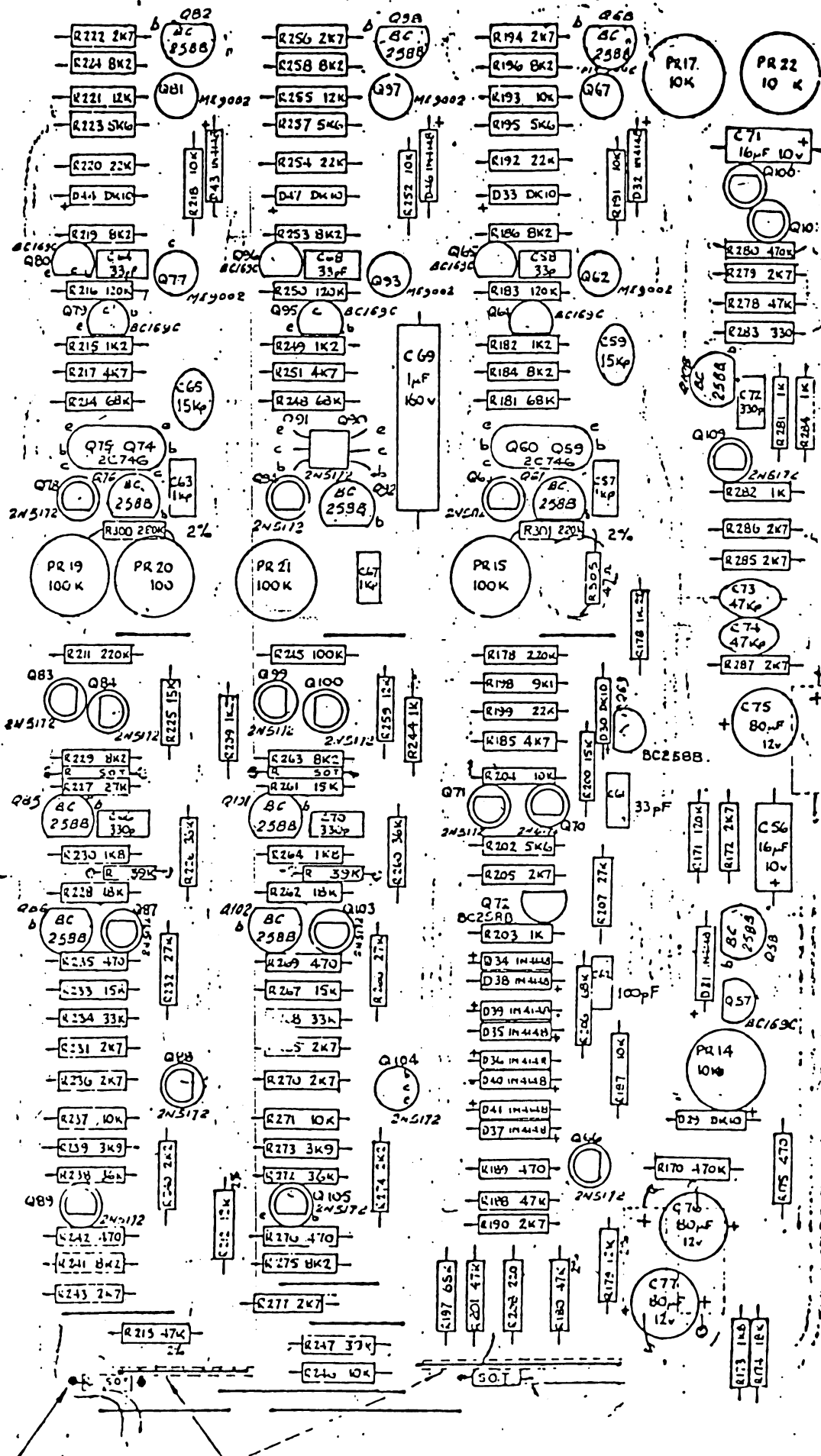

This document and its contents are the property of Electronic Music Studios (London) Ltd., and the information contained therein has been made available to you in confidence and is not to be disclosed to any other person or company.

CONFIDENTIAL INFORMATION

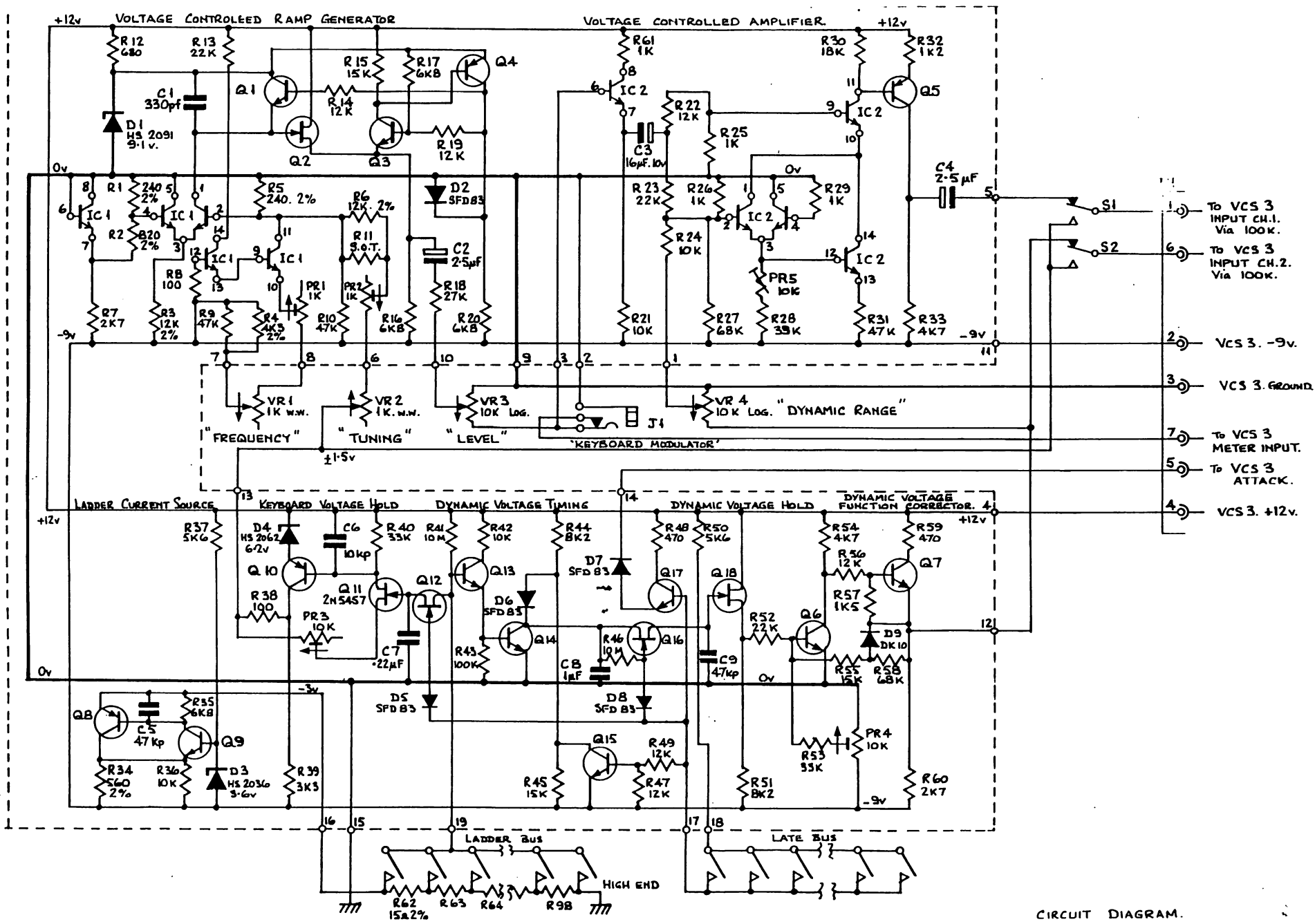

CIRCUIT DIAGRAM.
DYNAMIC KEYBOARD.

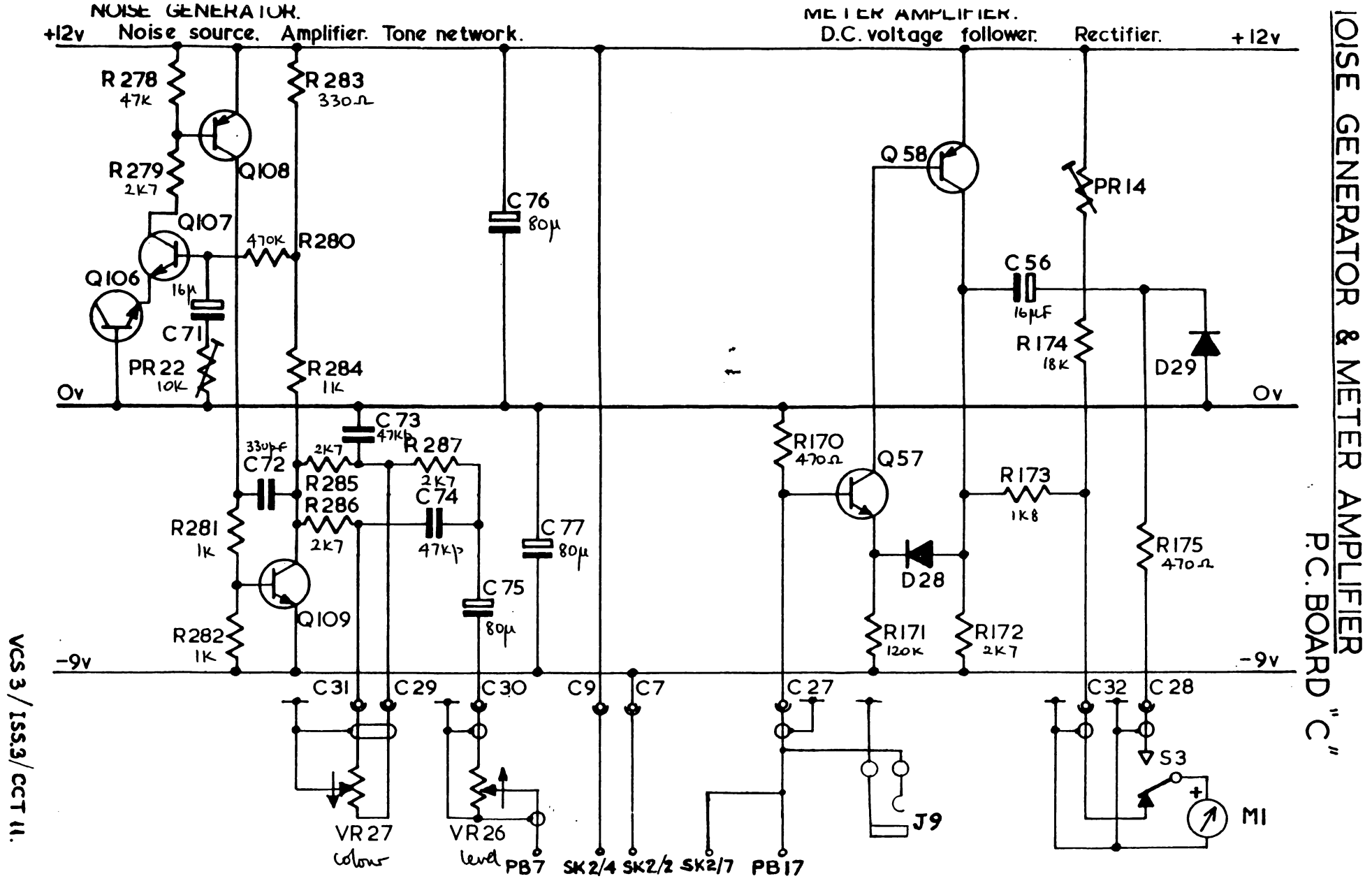

VCS 3 / ISS.3 / C.T 11.

NOISE GENERATOR & METER AMPLIFIER
P.C. BOARD "C"

Anti-log frequency control summer.

Integrator.

Hysteretic switch

D.C. shifter.

Rectifier.

Square wave output.

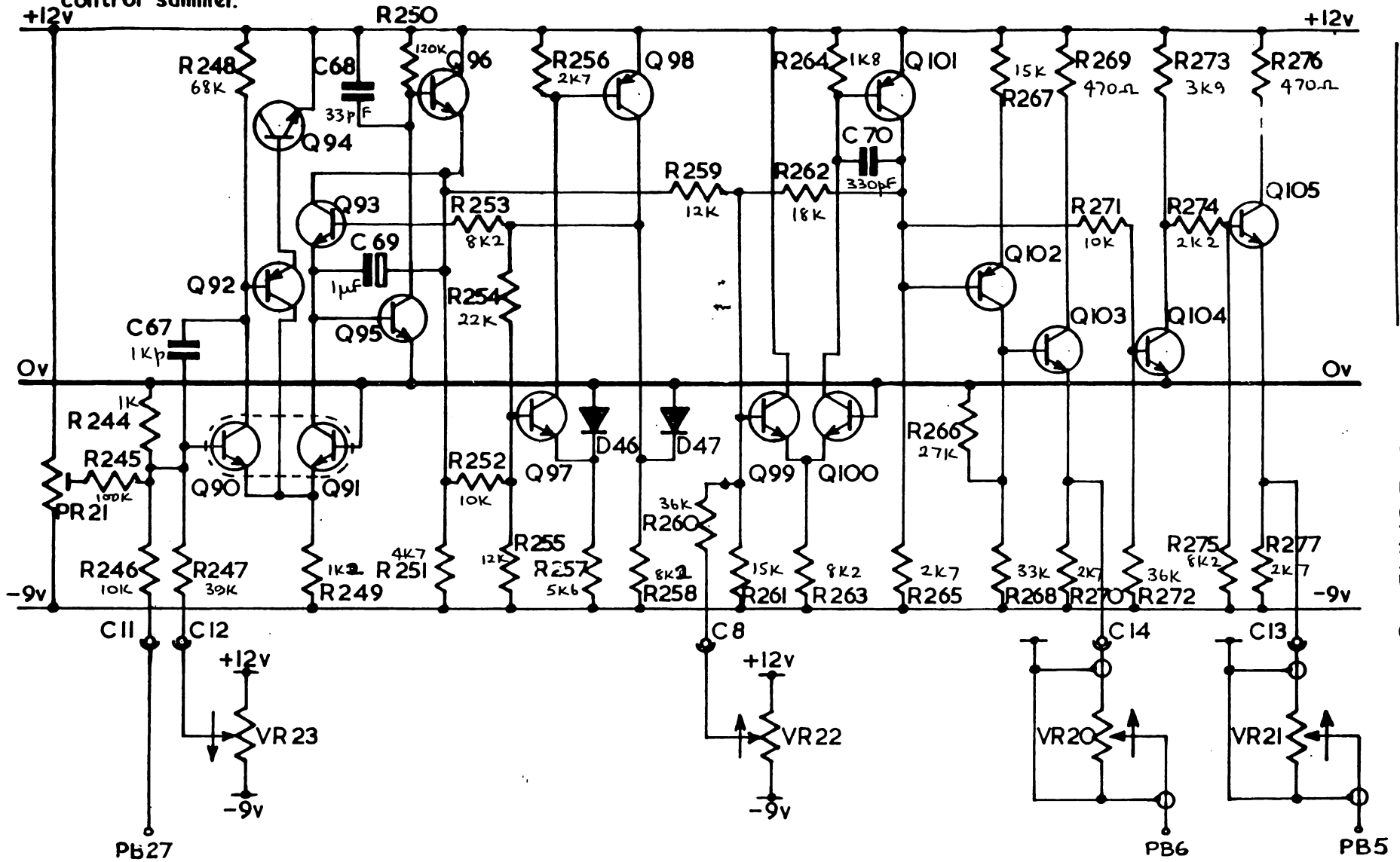

VCS 3 / ISS2 / CCT 10

OSCILLATOR 3

P.C. BOARD C.

Anti-log frequency +12v control summer. Integrator. Hysteretic switch. D.C. shifter. Rectifier. Square wave output.

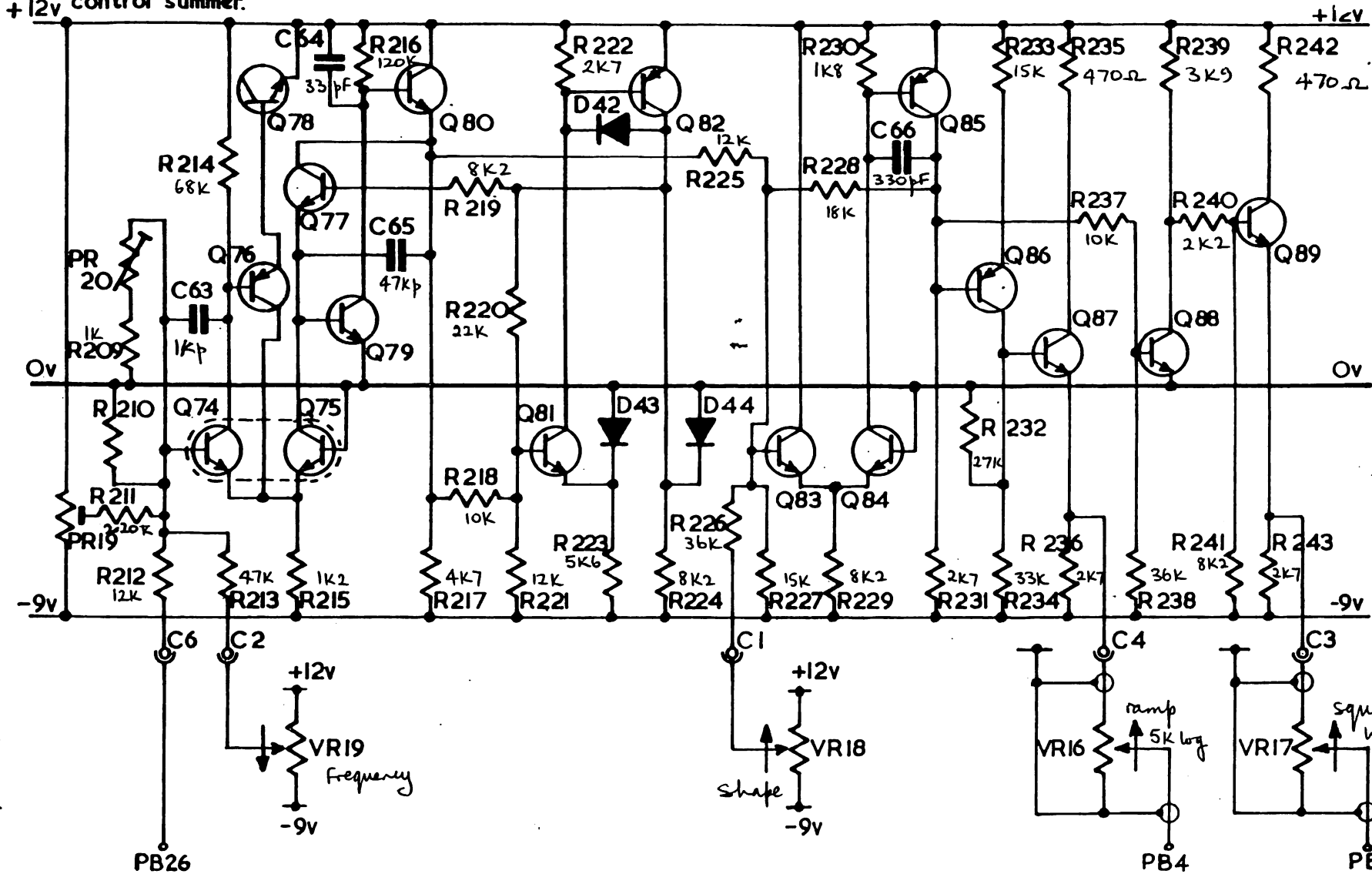

OSCILLATOR 2

P.C. BOARD

VCS3/ISS2/CCT 9

Anti-log frequency control summer.

Ramp integrator.

Hysteretic switch.

Triang to sine shaper.

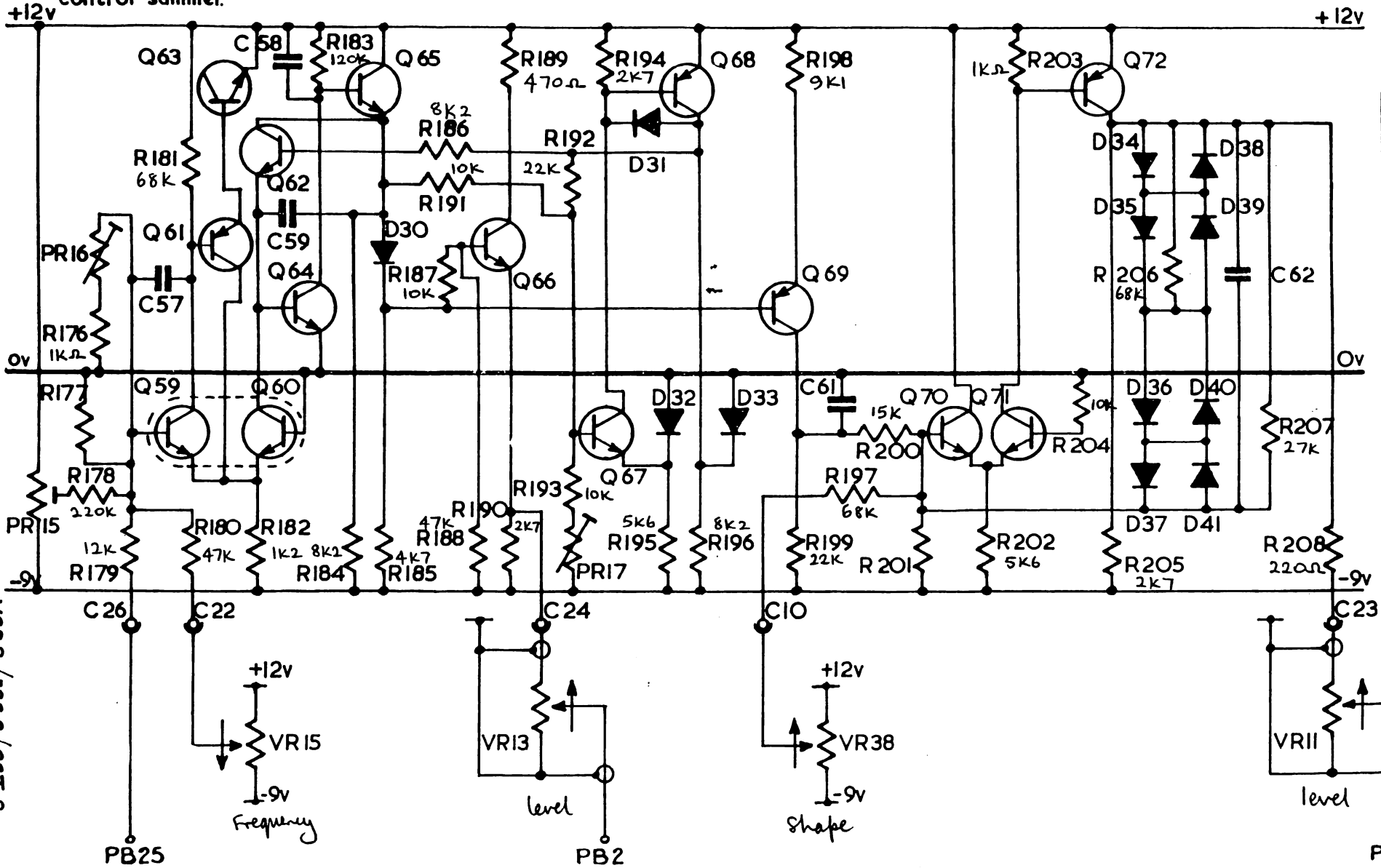

VCS 3 / ISS.2 / CCT 8.

P

INPUT CHANNEL AMPLIFIERS P.C.BOARD "B"

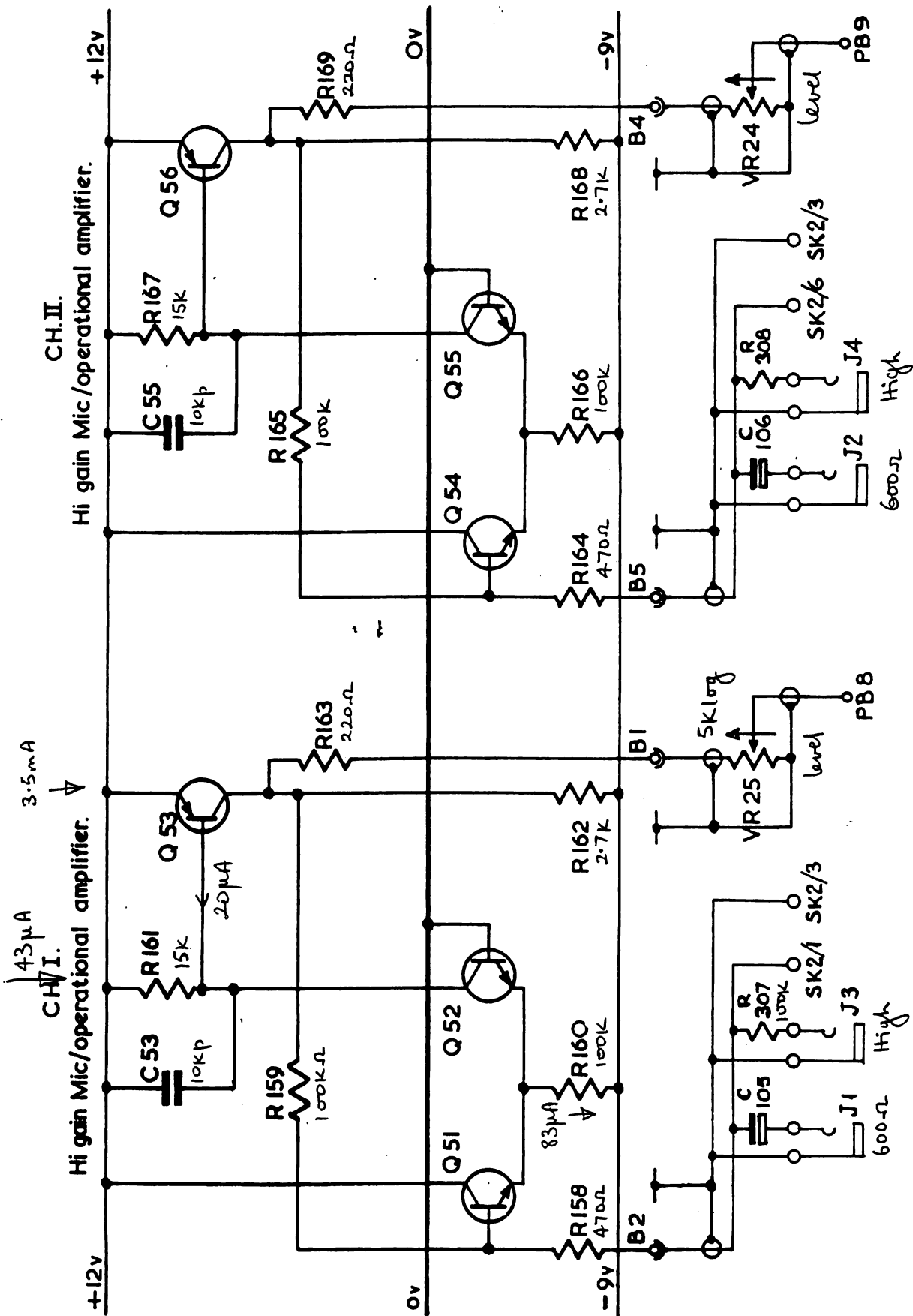

Double balanced modulator.

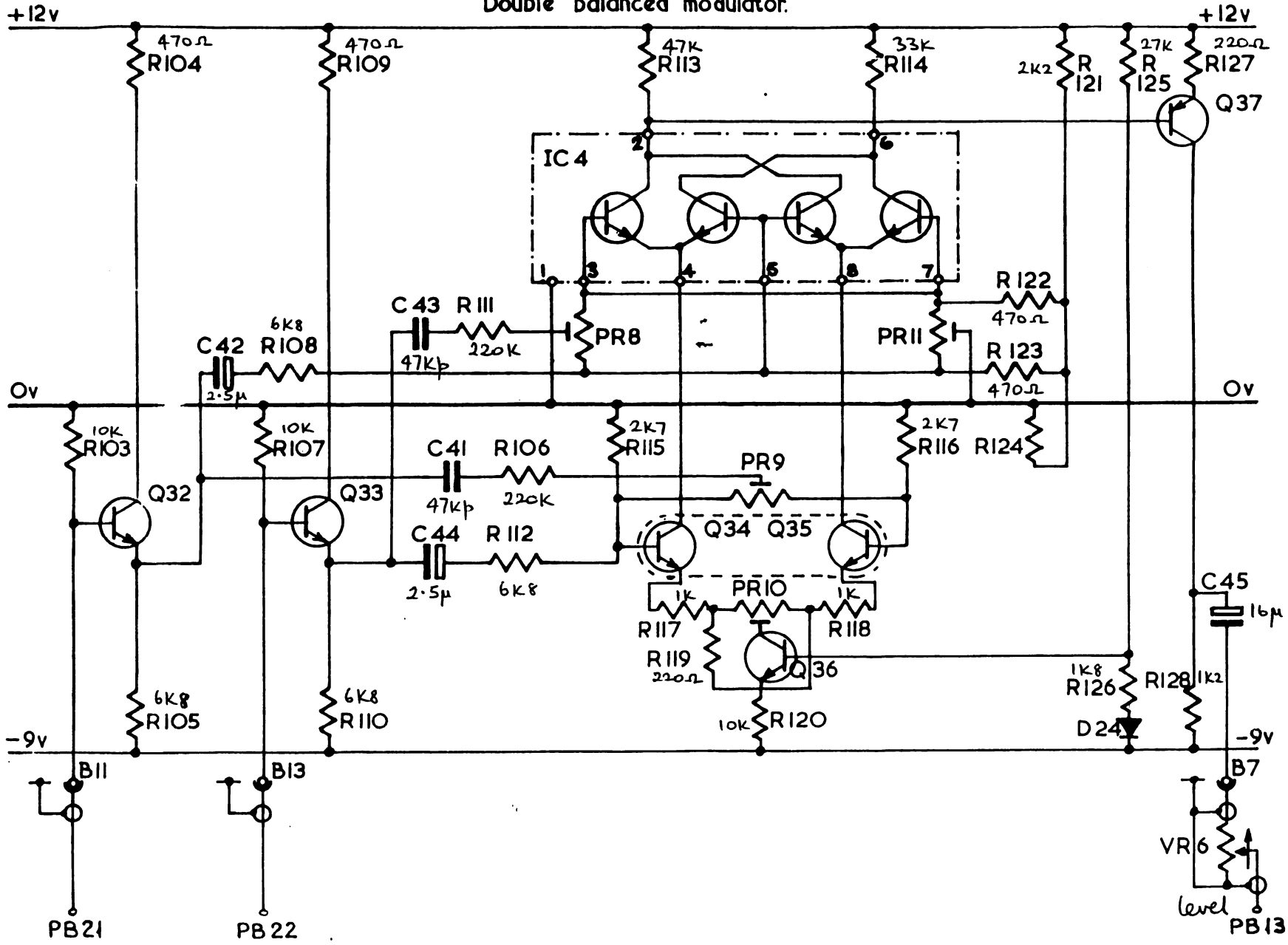

RING MODULATOR P.C. BOARD "B"

VCS3/ISS2/CCT 6

VCS 3/1553/CCT 5.

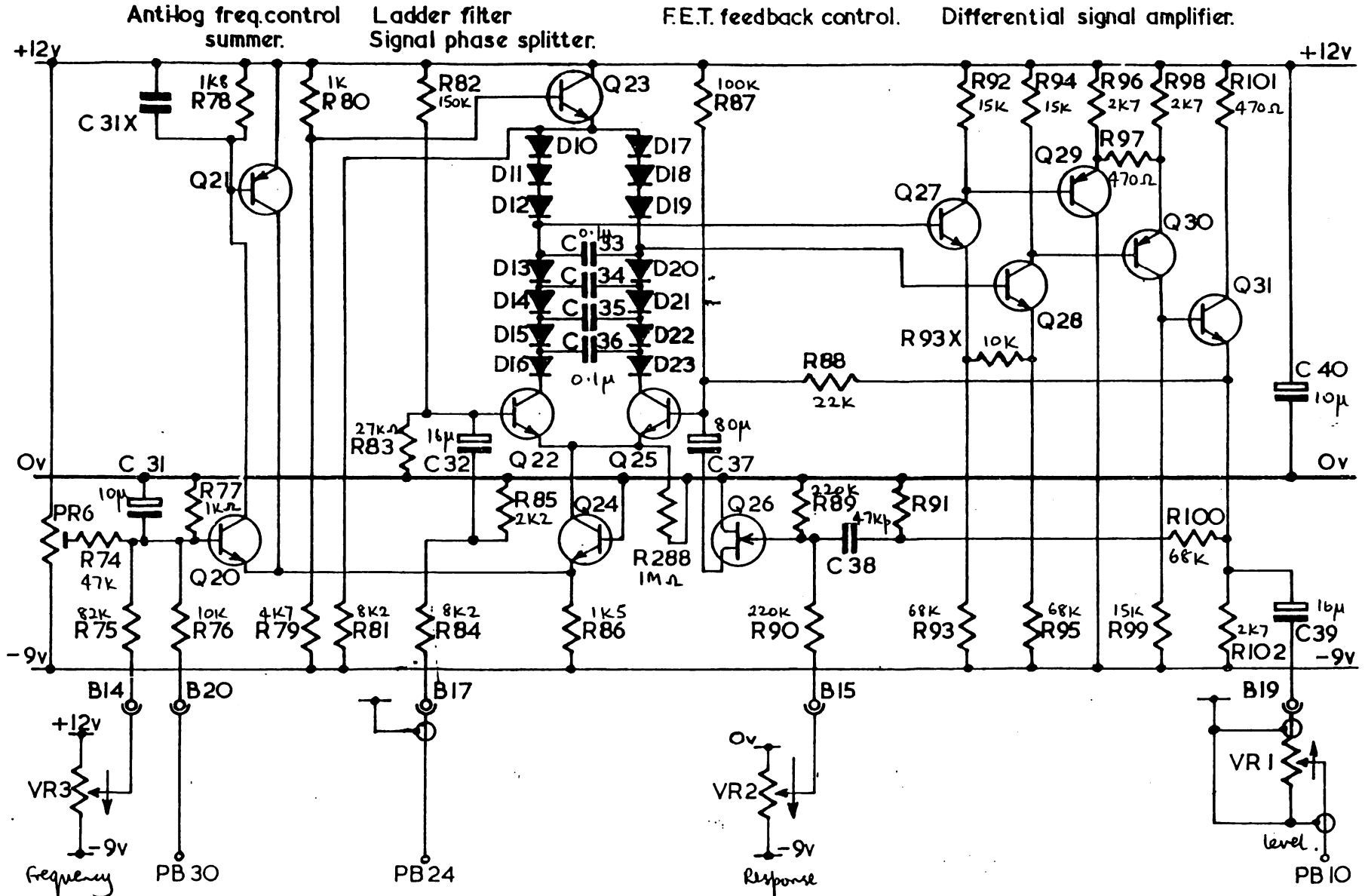

FILTER P.C. BOARD B

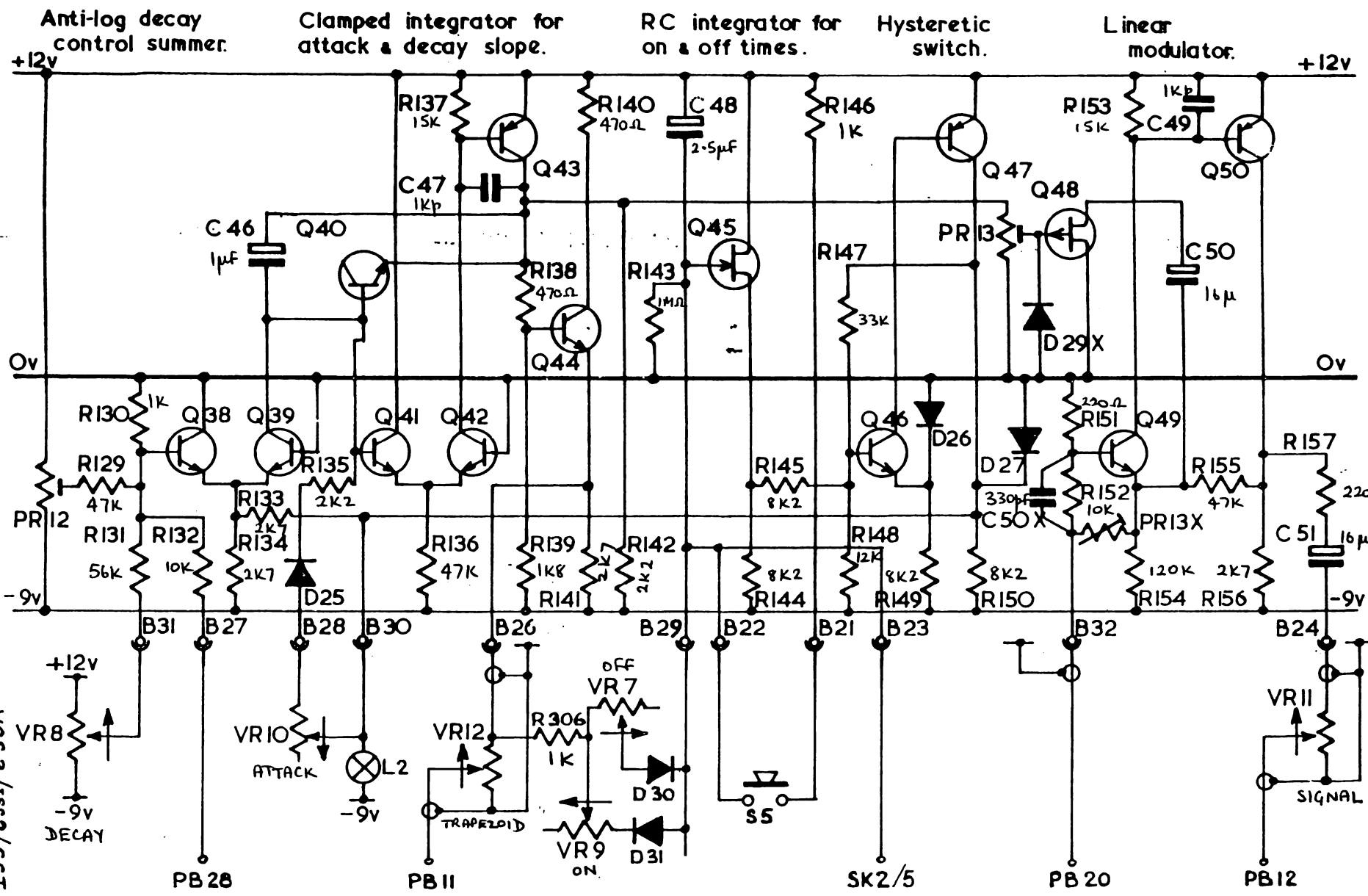

ENVELOPE SHAPER P.C. BOARD B

VCS 3/ISS2/CCT 4.

REVERBERATION

P.C. BOARD "A"

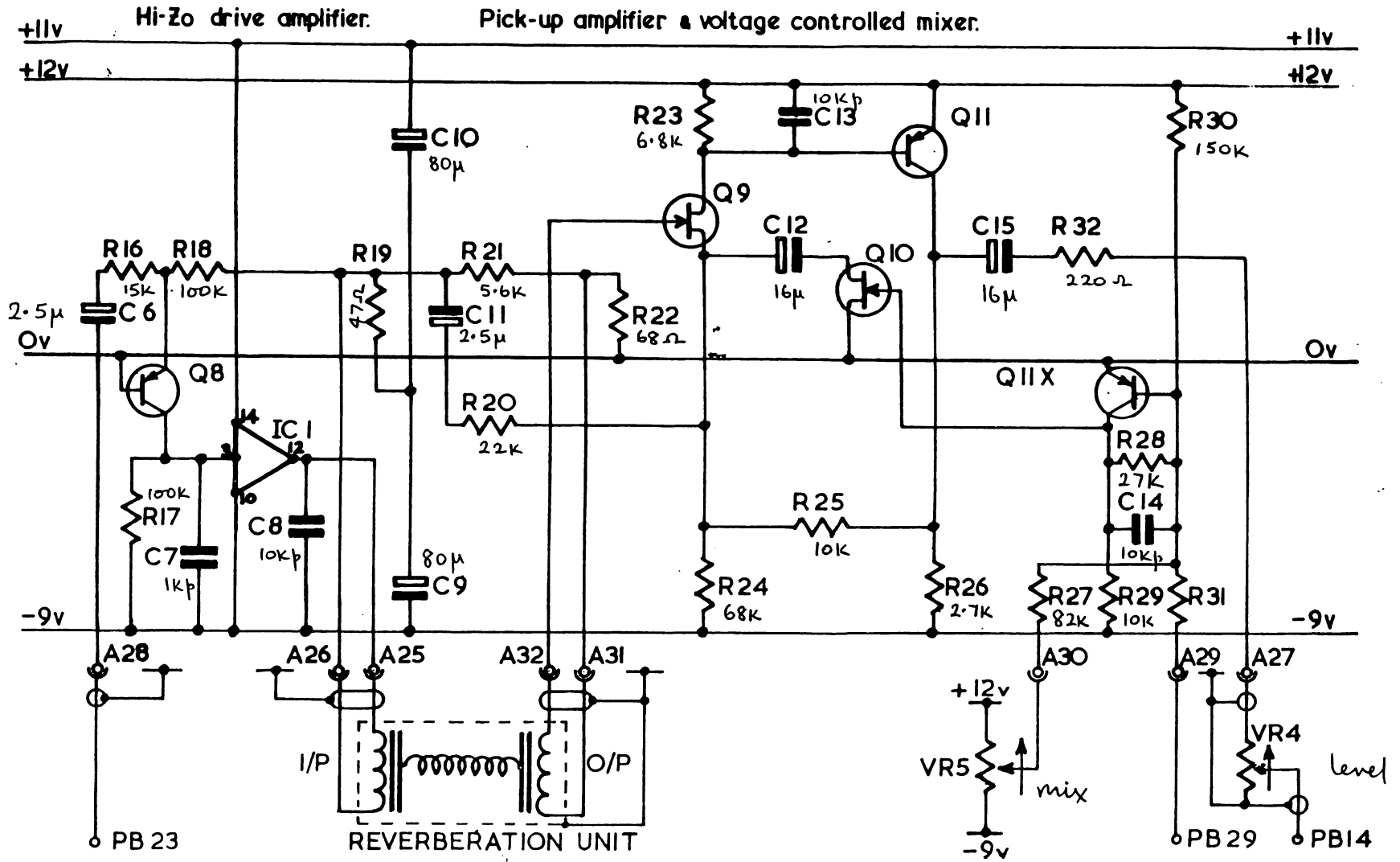

Ch. 1.

Ch. 2.

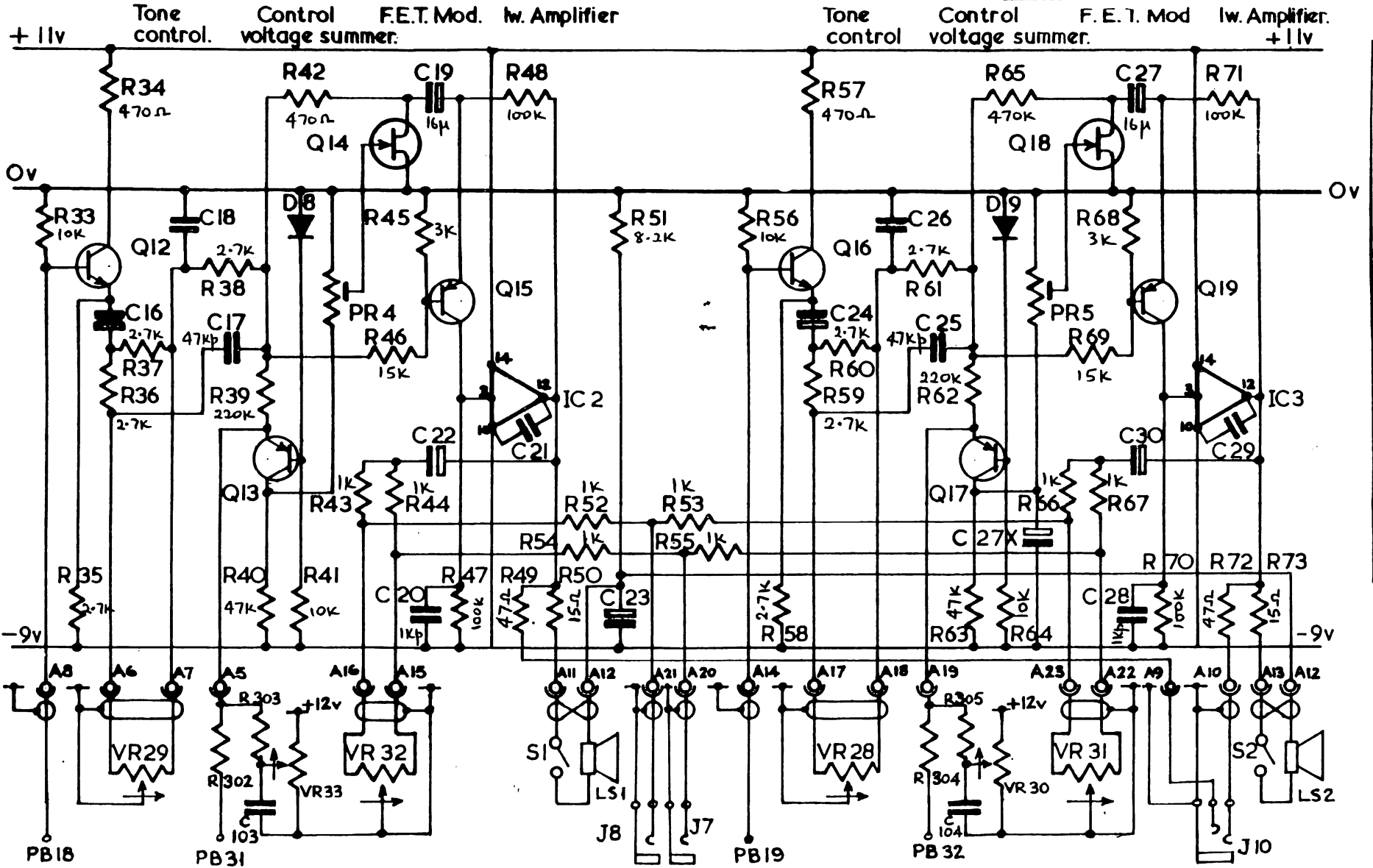

VC53 / ISS.2 / C.T.2.

OUTPUT CHANNEL AMPLIFIERS F. O. DONOVAN

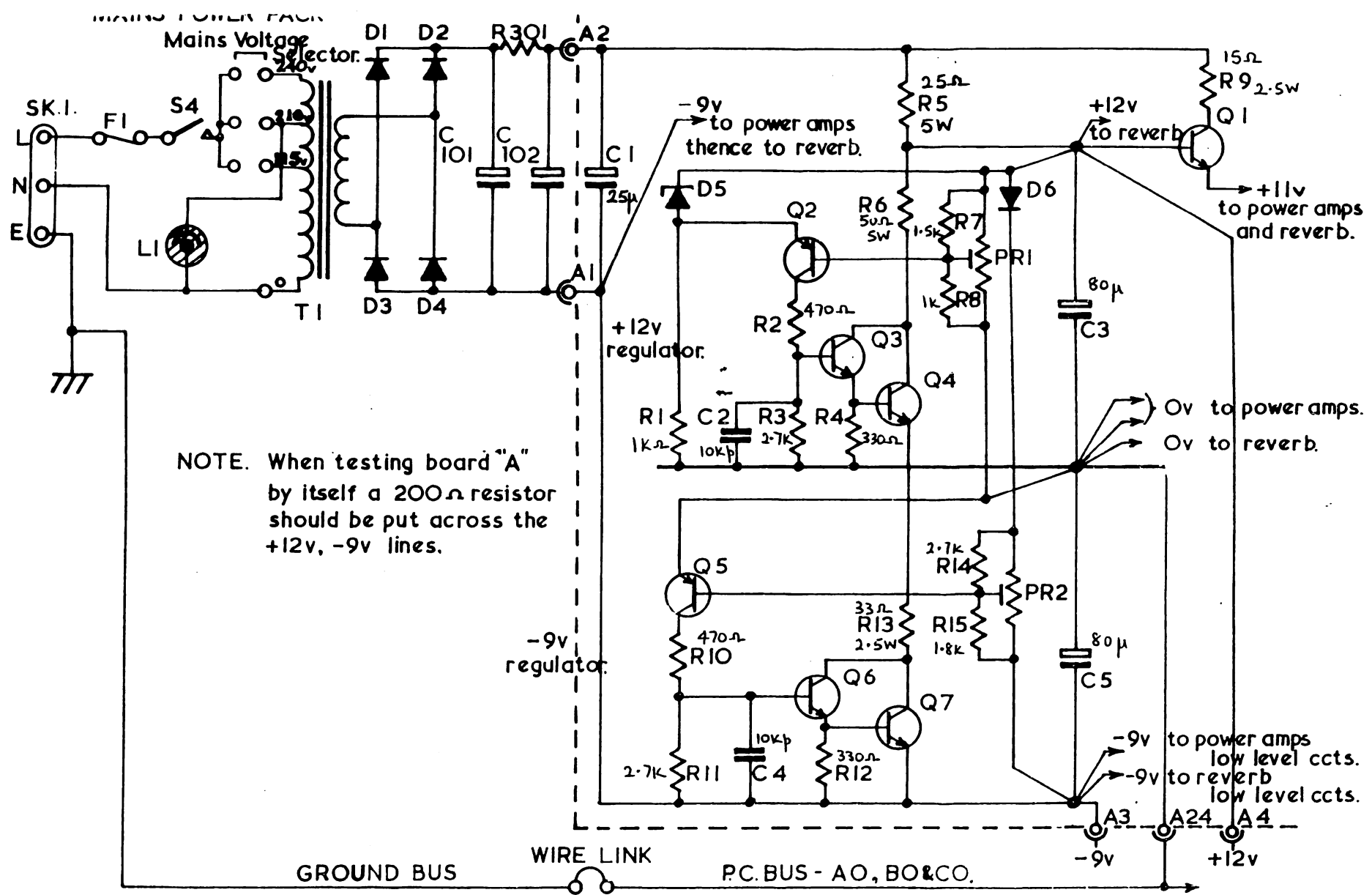

Dynamic Keyboard - Setting-up procedure

Set all knobs and presets halfway.

First set the keyboard zero volts at middle F sharp. Press middle F sharp with scope on Pin 13 of keyboard circuit. Adjust PR3 for 0 Volts \pm 50 mV.

Check that top C gives 1.5V \pm 200 mV

Check that bottom C gives -1.5V \pm 200 mV

Check drift rate when key is released. Should be less than 100 mV per minute.

If greater suspect Q12. This should have a Vp of 2.5 - 3.0.

Keyboard Oscillator

Press middle F sharp. With VR1 (Frequency) at 5 and VR3 clockwise put scope on live connection of jack socket 'Keyboard Modulator'. Adjust PR1 for 248 Hz at F sharp or 261 Hz for middle G.

If PR1 is off range clockwise then snip R9.

If PR1 is off range counterclockwise then reduce R9 value by half.

Hold down bottom C, and set VR2 (Tuning) to 5. Press C one octave higher.

Trim PR2 to get exactly an octave higher than bottom C.

If PR2 is off range clockwise then snip R11

If PR2 is off range counterclockwise suspect circuit fault.

With Frequency at 0 press lowest note. Should be lower than 30 Hz.

With Frequency at 10 press highest note. Should be higher than 8 kHz.

Dynamic Voltage

Short across C9 and trim PR4 for +3V at Pin 12 on keyboard circuit.

DO NOT PRESS A KEY WITH SHORT IN PLACE.

Check for drift, which should be less than 100mV in ten seconds.

Check that Dynamic Range has no effect on keyboard oscillator loudness when turned to zero. If so re-adjust PR4.

Contact Displacement

Each note has two sets of contacts. One pair, that is not connected to the resistors, must be adjusted to make about .03" after the other pair. With practice it is possible to do this by eye using a fine pair of tweezers. With VR1 and VR2 halfway, VR3 and VR4 fully clockwise and both switches up. Monitor the signal output on a scope. Strike each note with an even force. This should give about 10 dB less ($\frac{1}{2}$ as much) than hitting it hard. Maximum level should give about 2V p.p on the scope. Adjust the crooked member of the late pair where necessary. Closing the gap makes the note louder. If

Dynamic Keyboard - Contact displacement(continued)

visual alignment still gives performance inconsistencies this is almost certainly due to contacts being dirty. This is a frequent source of problems on the keyboard generally, giving swoops and dithering pitches at different places on the keyboard. Use cotton buds and Isopropyl alcohol to carefully wipe each surface of each contact. Extreme care must be taken not to disturb the contact displacement, but this will restore precision to the keys. Never use an abrasive substance on contacts since they are gold-plated. Blistered plating means new contacts must be fitted.

Setting up DK2 keyboard

DK2 keyboards are duophonic, so that Channel 1 pitch voltage comes from the lower note being played, with Channel 2 pitch voltage coming from the upper note. This second upper note voltage is derived from the lower note and PR6 needs to be adjusted to get the relationship right. Connect Channel 2 Voltage to control an oscillator with the Input Channel gain at maximum. Hold down the bottom key with sellotape and play the top note. If the oscillator pitch shifts adjust PR6 until there is no more movement. Some keyboards were modified from DK1 (monophonic) to DK2 by the addition of a small pc board under the main one. In these cases PR6 is the preset on the small board.

TOUCH KEYBOARD

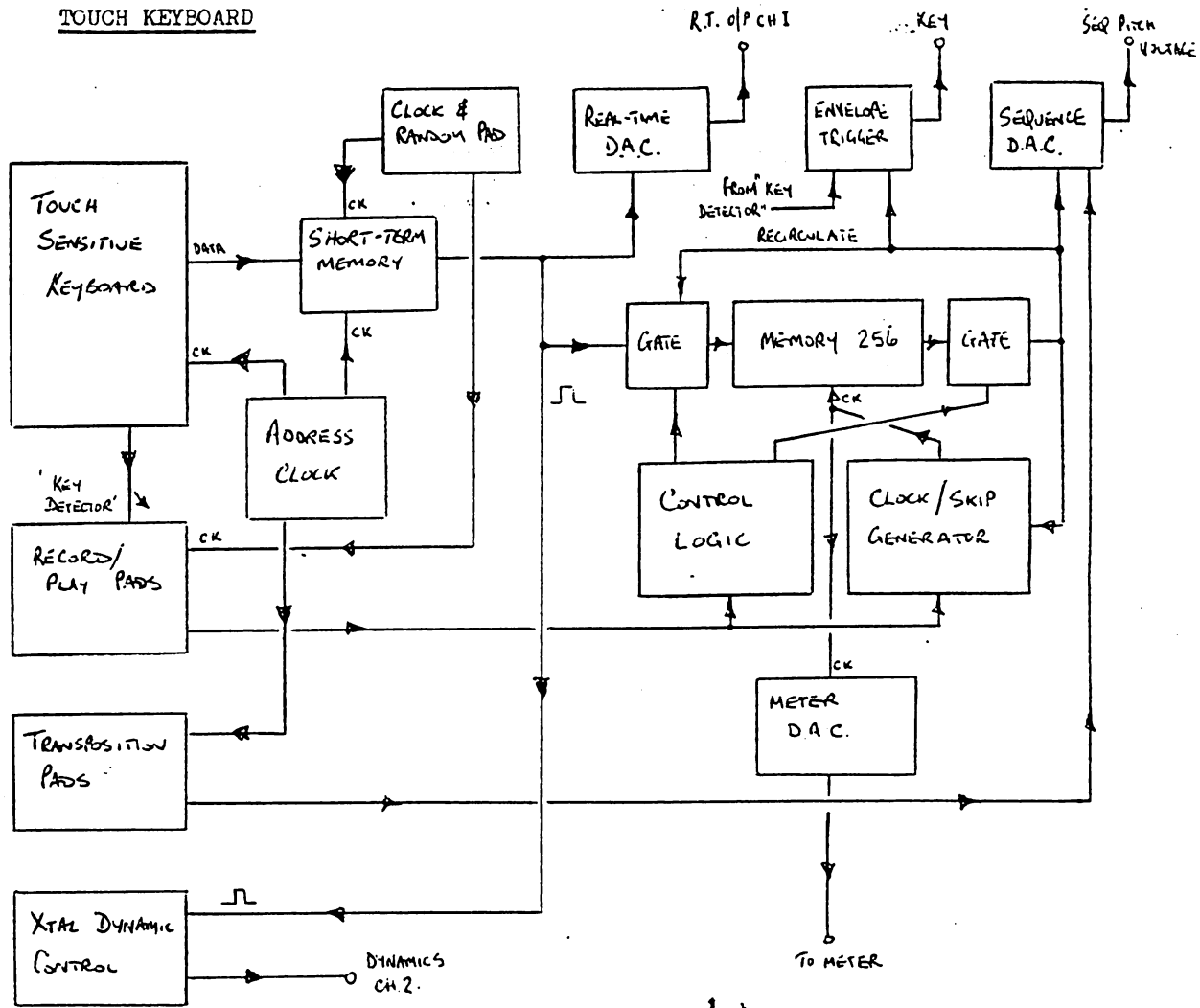

FIRSTLY. The Touch Keyboard and address clock.

The address clock is an oscillator, E28 (Pins 1,2,4,5,6), being a conventional schmitt trigger oscillator.

OPERATION Pin 6 is high; D38, 43 are off, C1 and C1X charged up by way of Pins 1,2,4,5 until upper threshold voltage (about +1.7v) is reached, the schmitt then fires, Pin 6 goes low, D38, 43 turn on and discharges C1 and C1X until the lower threshold voltage (about 0.9v) is reached. The schmitt then reverts back to its original state etc.etc.

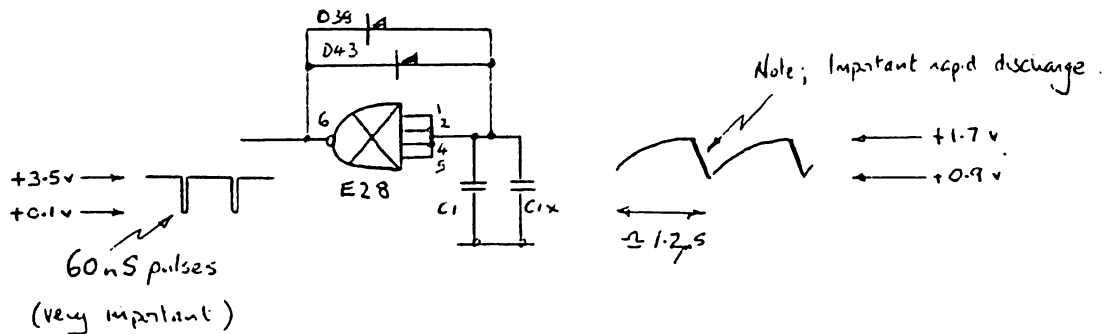

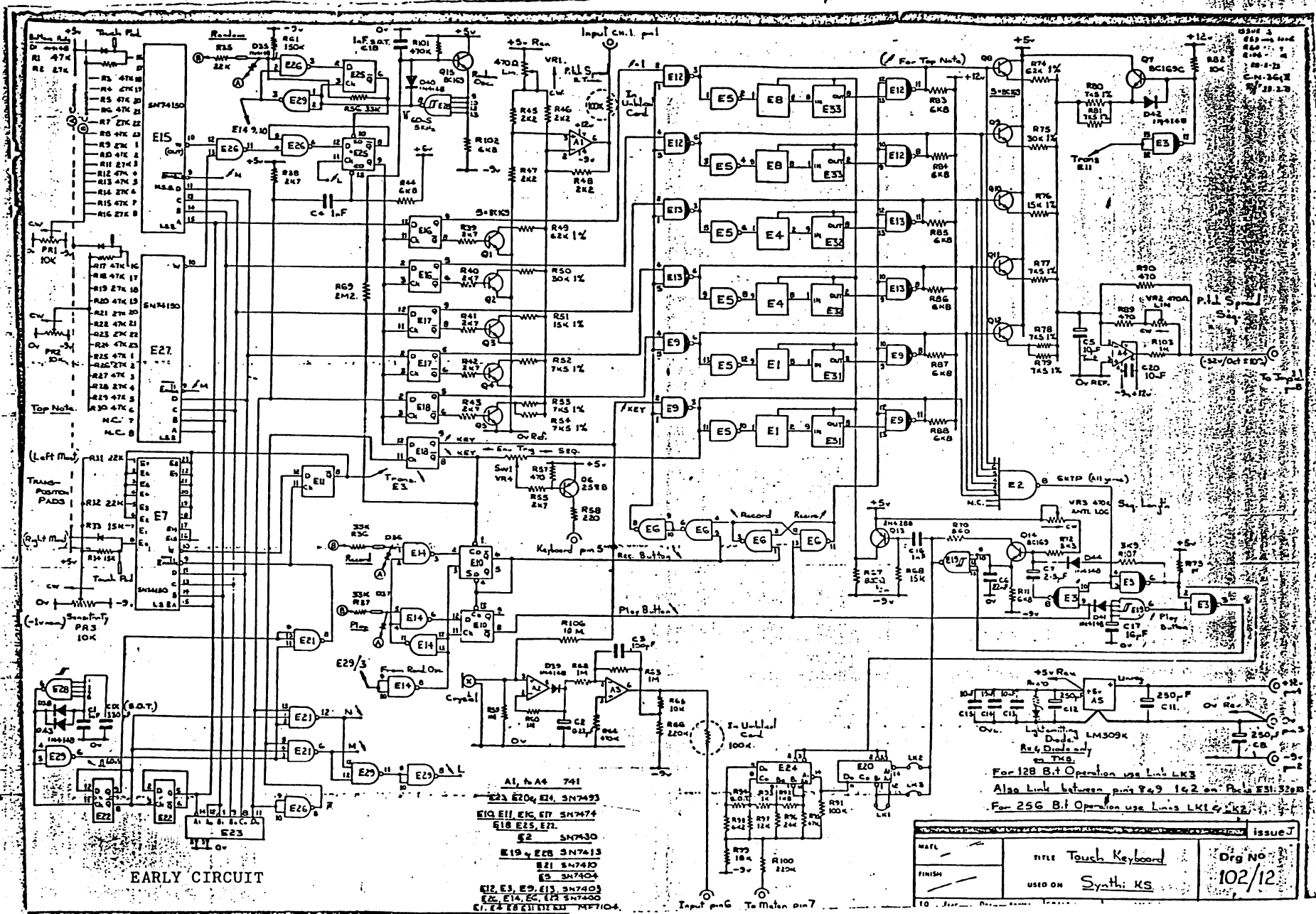

EARLY CIRCUIT

- A1, A4 741
- E23 E20, E4 SN7493
- E10, E11, E10, E17 SN7474
- E18 E25, E22
- E2 SN7430
- E19, E28 SN7413
- E21 SN7410
- E5 SN7404
- E12, E3, E9, E13, SN7403
- E20, E14, E2, E15 SN7400
- E1, E4, E6, E11, E22 - M7104

For 128 B.t. Operation use Link LK3
 Also Link between pins 9, 9 1, 2 on Pairs E31, E32
 For 256 B.t. Operation use Links LK1 & LK2

MATL	TITLE Touch Keyboard	Issue J
FINISH	USED ON Synth. KS	Org No 102/12

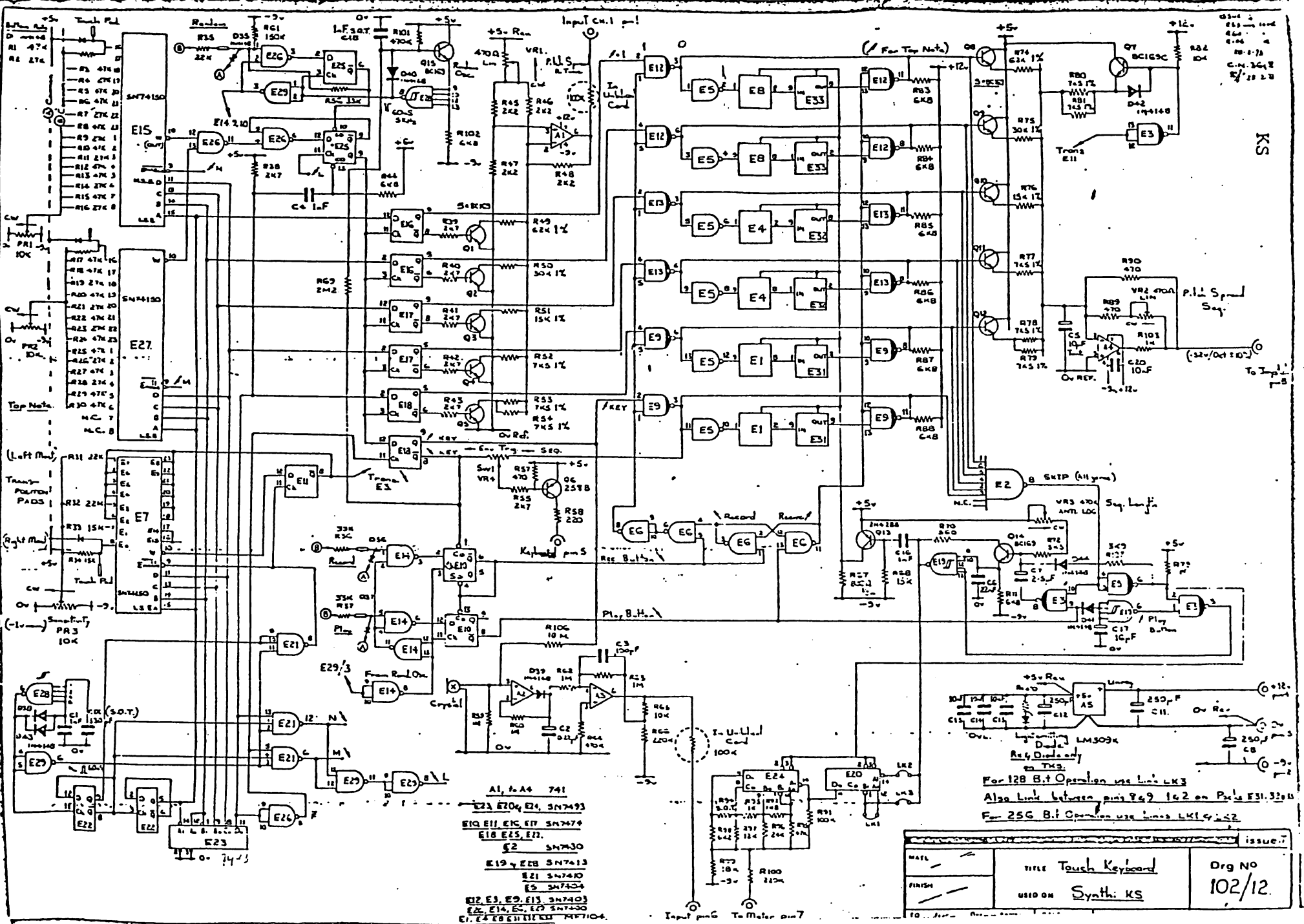

KS

03-11
03-12
03-13
03-14
03-15
03-16
03-17
03-18
03-19
03-20
03-21
03-22
03-23
03-24
03-25
03-26
03-27
03-28
03-29
03-30
03-31
04-01
04-02
04-03
04-04
04-05
04-06
04-07
04-08
04-09
04-10
04-11
04-12
04-13
04-14
04-15
04-16
04-17
04-18
04-19
04-20
04-21
04-22
04-23
04-24
04-25
04-26
04-27
04-28
04-29
04-30
04-31
05-01
05-02
05-03
05-04
05-05
05-06
05-07
05-08
05-09
05-10
05-11
05-12
05-13
05-14
05-15
05-16
05-17
05-18
05-19
05-20
05-21
05-22
05-23
05-24
05-25
05-26
05-27
05-28
05-29
05-30
05-31
06-01
06-02
06-03
06-04
06-05
06-06
06-07
06-08
06-09
06-10
06-11
06-12
06-13
06-14
06-15
06-16
06-17
06-18
06-19
06-20
06-21
06-22
06-23
06-24
06-25
06-26
06-27
06-28
06-29
06-30
06-31
07-01
07-02
07-03
07-04
07-05
07-06
07-07
07-08
07-09
07-10
07-11
07-12
07-13
07-14
07-15
07-16
07-17
07-18
07-19
07-20
07-21
07-22
07-23
07-24
07-25
07-26
07-27
07-28
07-29
07-30
07-31
08-01
08-02
08-03
08-04
08-05
08-06
08-07
08-08
08-09
08-10
08-11
08-12
08-13
08-14
08-15
08-16
08-17
08-18
08-19
08-20
08-21
08-22
08-23
08-24
08-25
08-26
08-27
08-28
08-29
08-30
08-31
09-01
09-02
09-03
09-04
09-05
09-06
09-07
09-08
09-09
09-10
09-11
09-12
09-13
09-14
09-15
09-16
09-17
09-18
09-19
09-20
09-21
09-22
09-23
09-24
09-25
09-26
09-27
09-28
09-29
09-30
09-31
10-01
10-02
10-03
10-04
10-05
10-06
10-07
10-08
10-09
10-10
10-11
10-12
10-13
10-14
10-15
10-16
10-17
10-18
10-19
10-20
10-21
10-22
10-23
10-24
10-25
10-26
10-27
10-28
10-29
10-30
10-31
11-01
11-02
11-03
11-04
11-05
11-06
11-07
11-08
11-09
11-10
11-11
11-12
11-13
11-14
11-15
11-16
11-17
11-18
11-19
11-20
11-21
11-22
11-23
11-24
11-25
11-26
11-27
11-28
11-29
11-30
11-31
12-01
12-02
12-03
12-04
12-05
12-06
12-07
12-08
12-09
12-10
12-11
12-12
12-13
12-14
12-15
12-16
12-17
12-18
12-19
12-20
12-21
12-22
12-23
12-24
12-25
12-26
12-27
12-28
12-29
12-30
12-31

- A1, A4 741
- E21 E20, E21, SN7493
- E1Q, E11, E1C, E17 SN7474
- E1B, E25, E27
- E2 SN7430
- E19, E2B SN7413
- E21 SN7410
- E3 SN7404
- E12, E3, E9, E13 SN7403
- E4, E14, E15, E17 SN7430
- E1, E4, E10, E11, E12, E13, E14, E15, E16, E17, E18, E19, E20, E21, E22, E23, E24, E25, E26, E27, E28, E29, E30, E31, E32, E33, E34, E35, E36, E37, E38, E39, E40, E41, E42, E43, E44, E45, E46, E47, E48, E49, E50, E51, E52, E53, E54, E55, E56, E57, E58, E59, E60, E61, E62, E63, E64, E65, E66, E67, E68, E69, E70, E71, E72, E73, E74, E75, E76, E77, E78, E79, E80, E81, E82, E83, E84, E85, E86, E87, E88, E89, E90, E91, E92, E93, E94, E95, E96, E97, E98, E99, E100

For 128 Bit Operation use Line LK3
Also Link between pins 9, 9, 16, 2 on Pkts E31, 32, 33
For 256 Bit Operation use Lines LK1, 2, 3, 4, 5, 6, 7, 8, 9, 10, 11, 12, 13, 14, 15, 16, 17, 18, 19, 20, 21, 22, 23, 24, 25, 26, 27, 28, 29, 30, 31, 32, 33, 34, 35, 36, 37, 38, 39, 40, 41, 42, 43, 44, 45, 46, 47, 48, 49, 50, 51, 52, 53, 54, 55, 56, 57, 58, 59, 60, 61, 62, 63, 64, 65, 66, 67, 68, 69, 70, 71, 72, 73, 74, 75, 76, 77, 78, 79, 80, 81, 82, 83, 84, 85, 86, 87, 88, 89, 90, 91, 92, 93, 94, 95, 96, 97, 98, 99, 100

DATE	TITLE Touch Keyboard	Org NO
FINISH	USED ON Synth. KS	102/12
Issue 7		

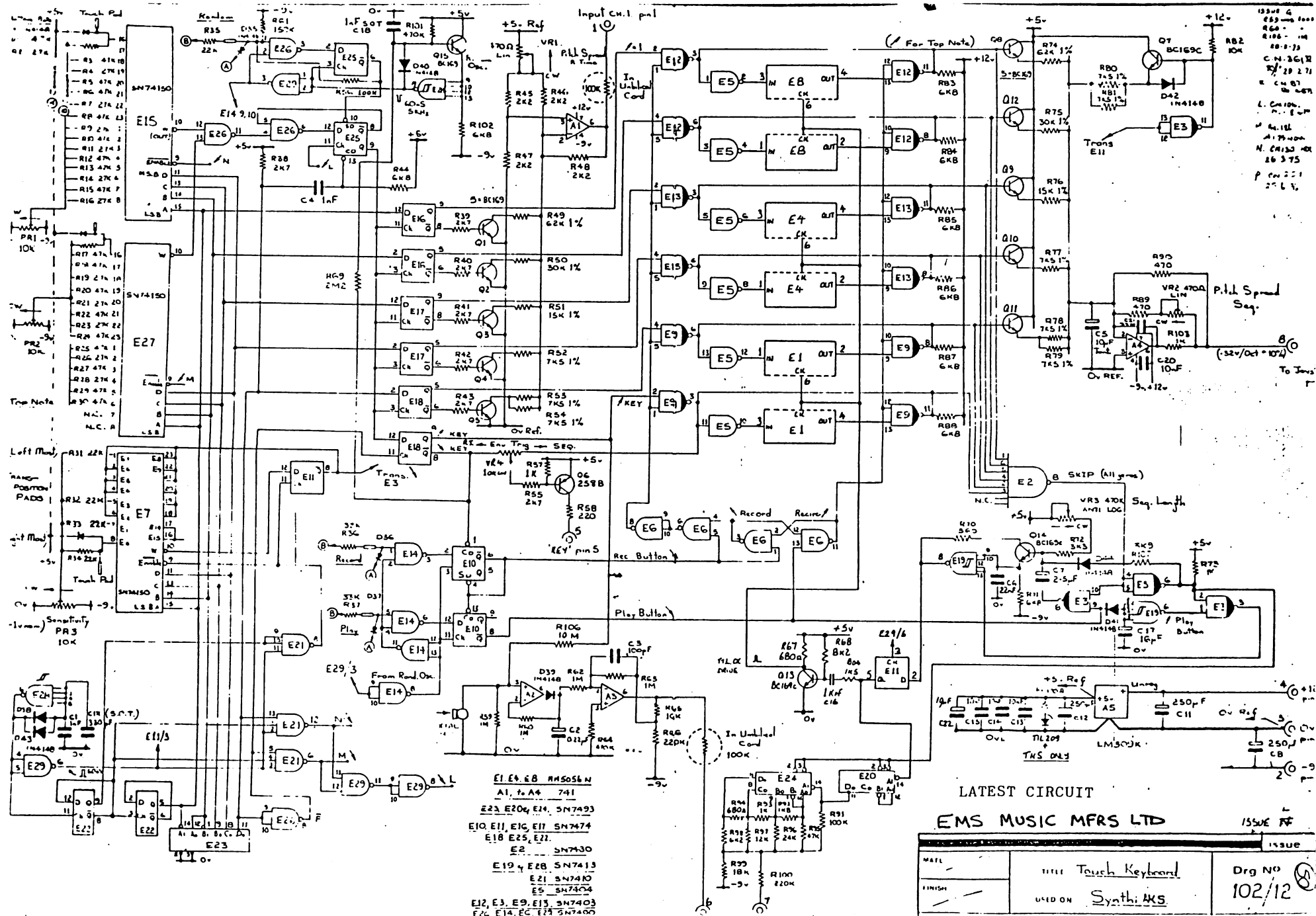

ISSUE 17
 1388 G
 1389 H
 1390 I
 1391 J
 1392 K
 1393 L
 1394 M
 1395 N
 1396 O
 1397 P
 1398 Q
 1399 R
 1400 S

- E1, E4, E8, A45056N
- A1, A4 741
- E23, E20, E14, SN7493
- E10, E11, E1C, E11, SN7474
- E18, E25, E21
- E2 SN7430
- E19, E28, SN7413
- E21, SN7410
- E5, SN7404
- E12, E3, E9, E13, SN7403
- E7, E14, E6, E24, SN7400

LATEST CIRCUIT

EMS MUSIC MFRS LTD

ISSUE 17

MATERIAL	11111 Touch Keyboard	Drg NO
FINISH	U-10 ON Synth. MKS	102/12

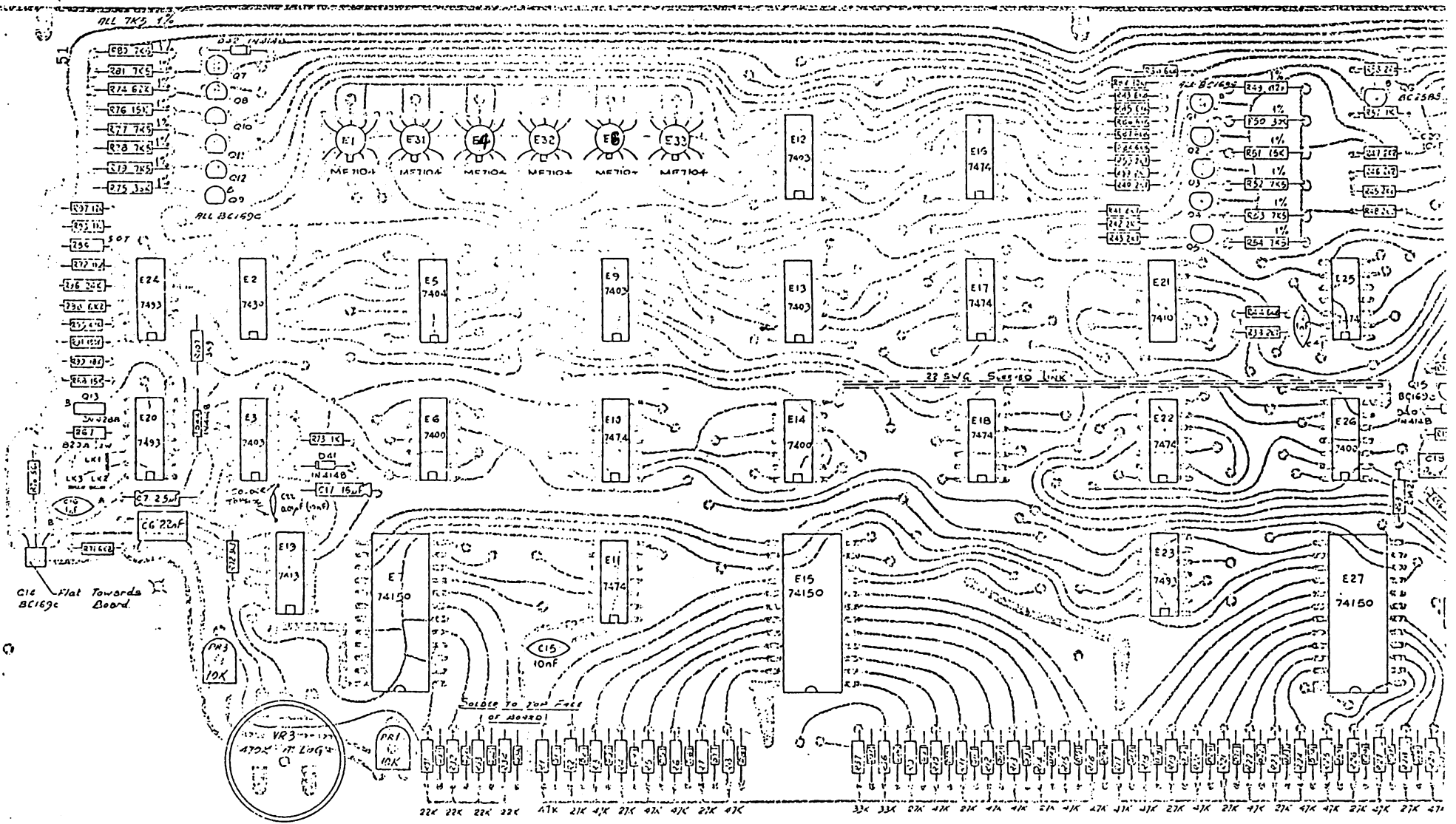

* INSERT LINK LK3 FOR 64 BIT STORAGE
INSERT LINK LK1, LK2 & PINS E31, E32 & E33 FOR 128 BIT STORAGE

UNLESS OTHERWISE STATED ALL DIODES 1N4148

NOTE WIRE LEADS SHOULD
AND THE WIRE LEADS
THE -4157AL 242...

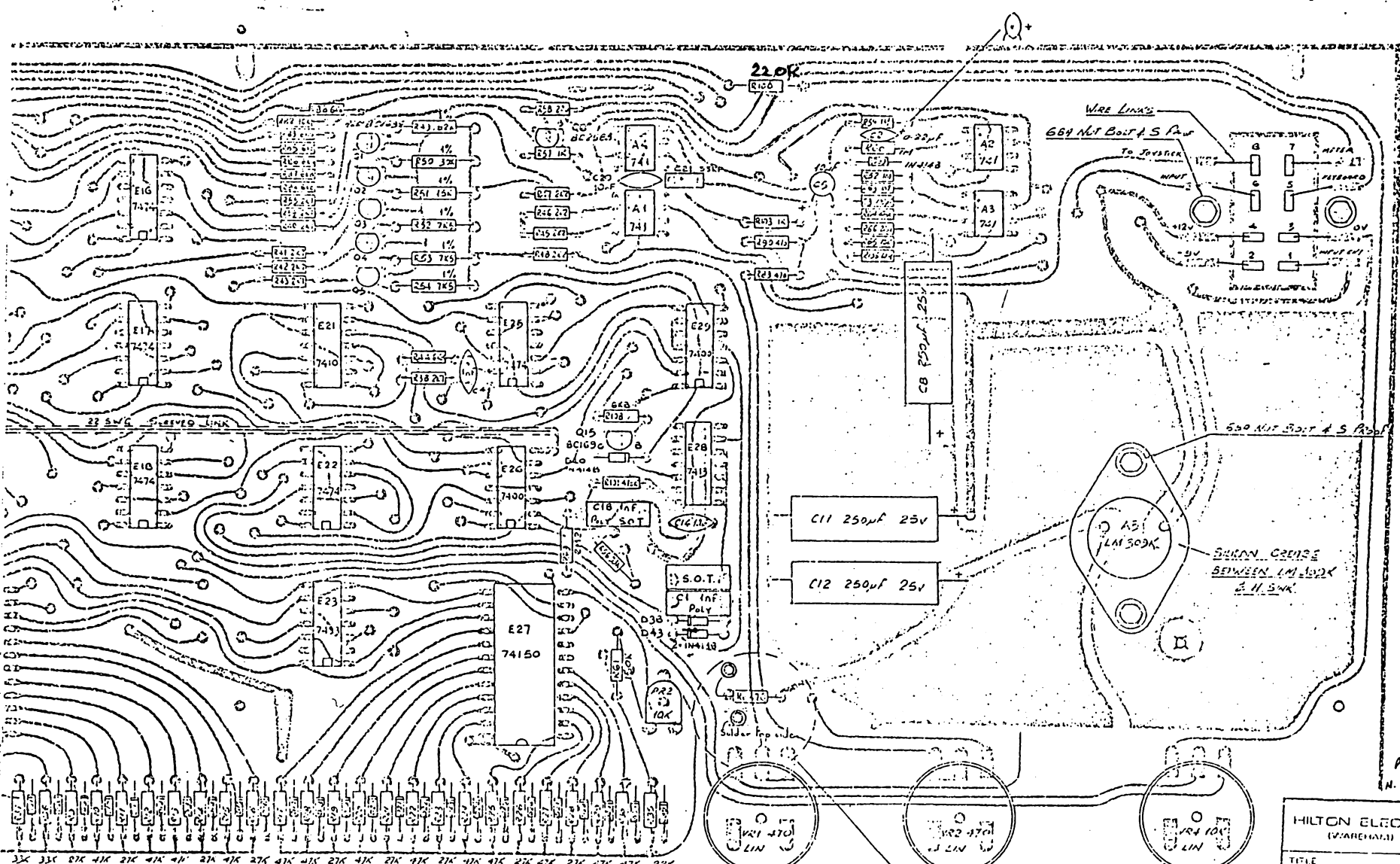

UNLESS OTHERWISE STATED ALL DIODES 1N4148

128 BIT STORAGE

NOTE Wire Leads should be soldered to the crystal leads and the wire leads are to be soldered into the AGC. The crystal should then be applied to the S-400

NOTE:
 PIN 14 : +5V } TYPES 7400, 7403, 7410, 7413, 7430, 7474.
 PIN 7 : 0V }
 PIN 5 : +5V }
 PIN 10 : 0V } TYPE 7453
 PIN 24 : +5V }
 PIN 12 : 0V } TYPE 7450

P. C. 1186
 N. S. L. 2-4-64

HILTON ELECTRONICS (WAREHOUSING) LTD			
TITLE TOUCH KEYBOARD ASSY. KKS.			
REV	DATE	BY	CHK
1	2-4-64		
DRAWN BY: [Signature]			
DRG NO 103/4			

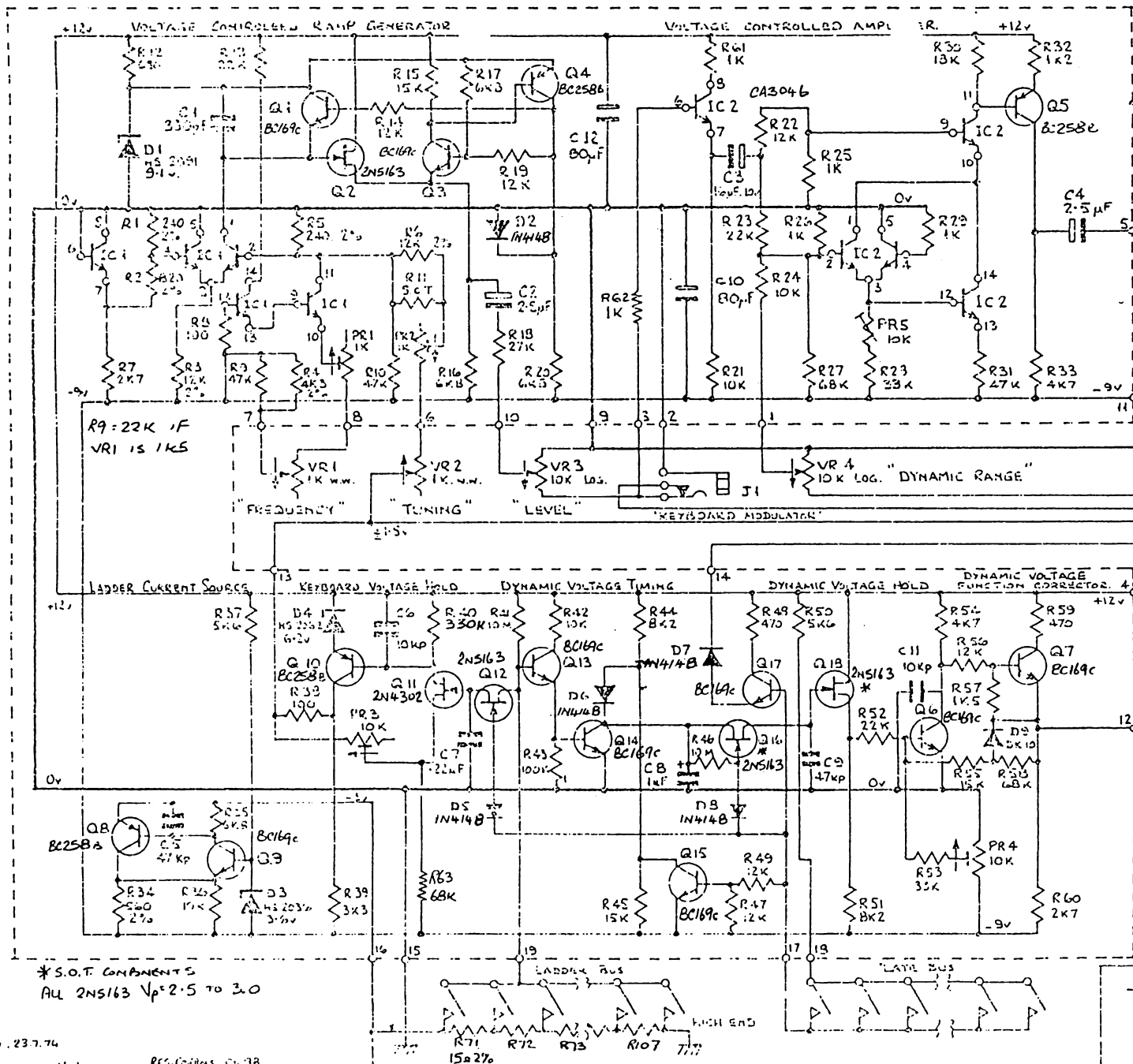

B C10 11 9 12
 add.
 20.7.71
 C. J. P. S. 10/5/71
 1/11 4-5-73
 W. CHANGES?
 MAIN P.C.B.
 PARTS LIST SHEETS 1-4
 D. 21.6.73
 E C.N. 46
 2/7/73
 F was OK!
 20/7/73.

TO VCS 3
 INPUT CH.1
 VIA 100K.
 TO VCS 3
 INPUT CH.2
 VIA 100K.
 VCS 3. -9v
 VCS 3. 0v
 TO VCS 3
 METER INPUT
 TO VCS 3
 ATTACK.
 VCS 3. +12v

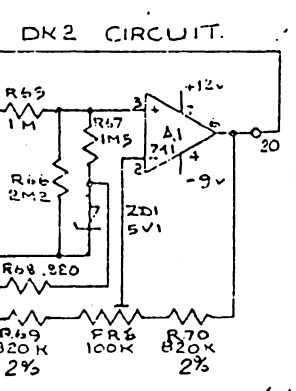

* S.O.T. COMPONENTS
 ALL 2N5163 Vp = 2.5 TO 3.0

C.N. 1/6 NOV. 23.7.74
 TRANSISTOR TYPE No's ADDED
 RESISTORS CH. 2R

ISSUE #H 4
 ELECTRONIC MUSIC STUDIOS
 DK2
 CIRCUIT DIAGRAM 22.0

DRG. No. 23/02

THIRD ANGLE PROJECTION

ISSUE	ALTERATIONS	DATE

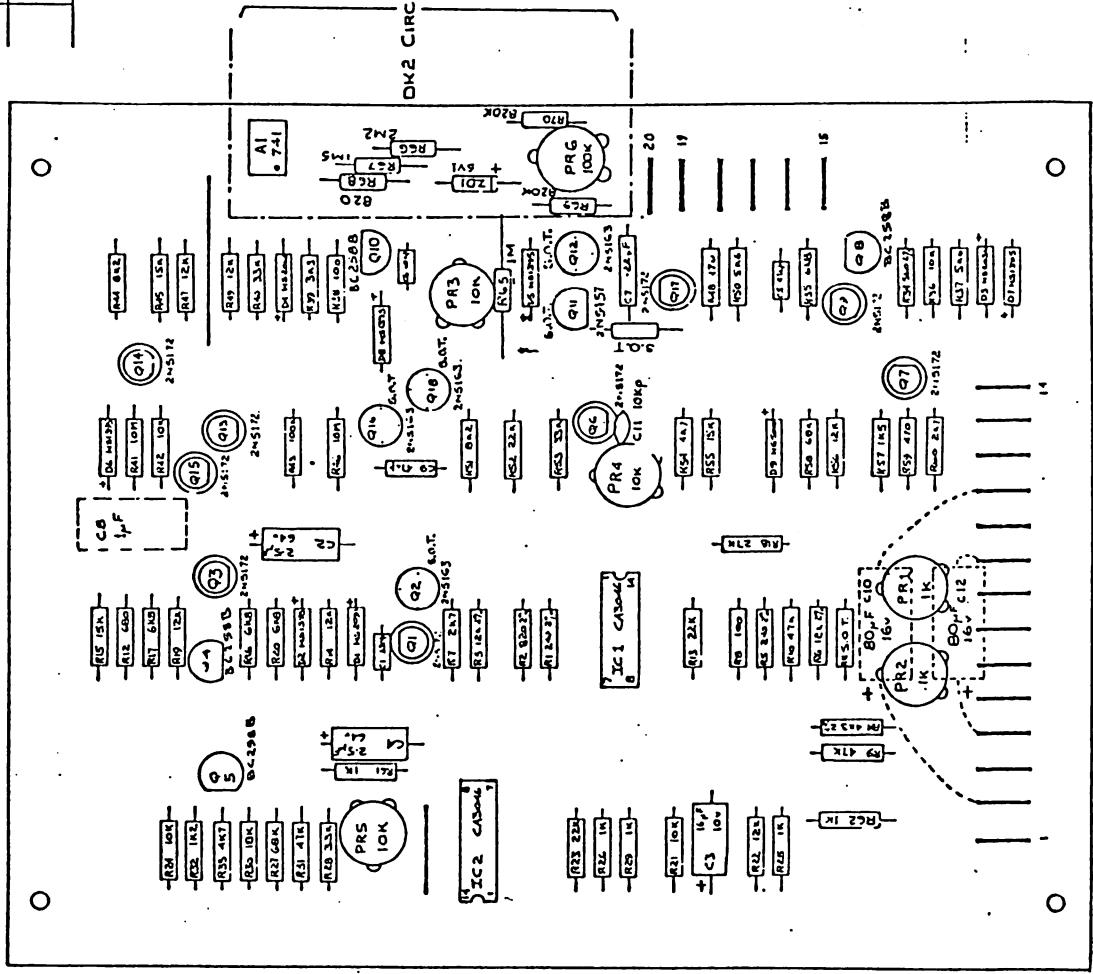

B Q14 Q15 R...
 C10, 11, 12 add.
 20 7. 7
 C Q1-Q10, D...
 on board with
 28.9.7
 9 units changed.
 8-4-73
 8. MOFF (09.00.00)
 now 62708
 was 24488
 30-4-73
 F AUXILIARY D.
 ADDED BY
 C N. G.
 2.6.73
 H was OK
 20.7.73
 J. S. T.

Q1	2N5112
Q2	2N5113
Q3	2N5112
Q4	2N5110
Q5	2N5112
Q6	2N5112
Q7	2N5112
Q8	2N5112
Q9	2N5112
Q10	2N5112
Q11	2N5112
Q12	2N5112
Q13	2N5112
Q14	2N5112
Q15	2N5112
Q16	2N5112
Q17	2N5112
Q18	2N5112
Q19	2N5112
Q20	2N5112

NOTES.
 1. C10 C11 C12 TO BE MOUNTED ON TRACK TABS
 2. Q3, 4, 5, 13, 14, 15 TO BE MOUNTED OUT ON P.4.B.

TOLERANCE	INCH	METRIC
3 FIGURE	H -005	H -1
	H -010	H -1

MATERIAL

TITLE

COMPONENT LAYOUT DK 2

USED ON

DRAWN	M.C.M	CHECKED
DATE	12-9-70	APPROVED
SCALE	2:1	TRACED

W

62

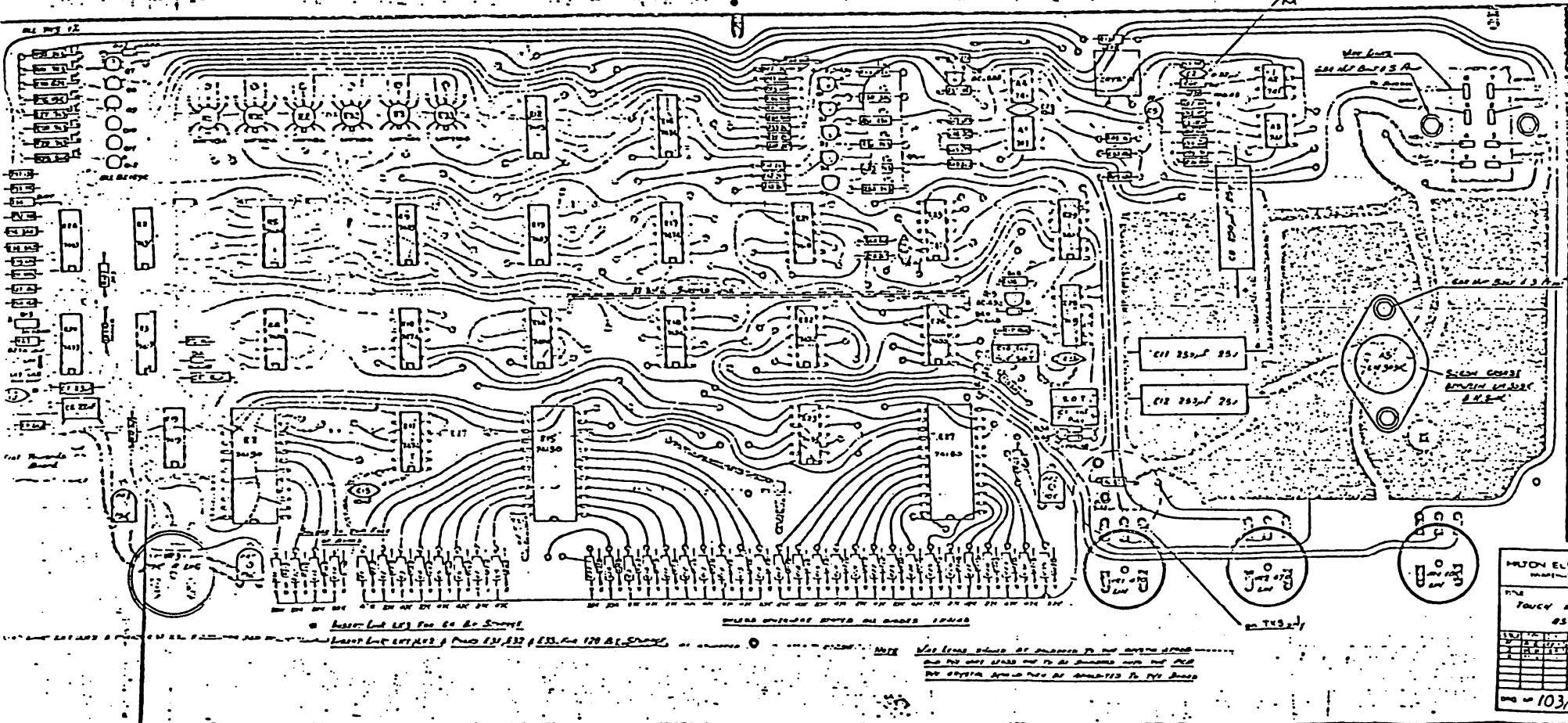

K.S.

MILTON ELECTRON
MARTIN 170

TYPE
TOUCH KEYBOARD
8537

REV	DATE	BY	CHKD

DRG NO 103/4

ASSEMBLY FOR 60 & 80 SERIES

WELDED WIREBOND BONDING ALL GRIDS. SPACES

NOTE: ALL LEADS SHOULD BE SOLDERED TO THE SYSTEM BOARD
AND THE UNIT SHOULD BE PLACED IN THE BOARD WITH THE
THE SYSTEM BOARD SHOULD BE SOLDERED TO THE BOARD