

## SPECIFICATIONS

- Memory Capacity** : 64 Rhythm Patterns (16 x 4 Group)  
**Track** : 4 (1 to 4; continuous Maximum measures=998)  
**Step** : 1 to 16 steps/measure  
**Tempo** :  $\text{♩}$  = 38 to 250  
  
**Rear Panel** : Master Out (L,R/MONO) [8Vp-p, 1K $\Omega$ ]  
**Trigger Out** : +5V, 20ms Pulse TR-707 . . . . . Rim Shot  
                   TR-727 . . . . . Hi Agogo  
**Sync In/Out (5P DIN)** : (1: Run/Stop, 2: GND, 3: Clock, 4: NC, 5: Continue)  
**Power Consumption** : 2.4 W  
**Dimensions** : 380 (W) x 73 (H) x 250 (D) mm  
                   14-15/16" (W) x 2-7/8" (H) x 9-13/16" (D) in  
**Weight** : 1.5 kg/13 lb. 5 oz.  
**Accessories** : 12V AC Adaptor  
                   Connection Cord PJ-1  
**Options** : Memory Cartridge M-64C  
                   Pedal Switch DP-2

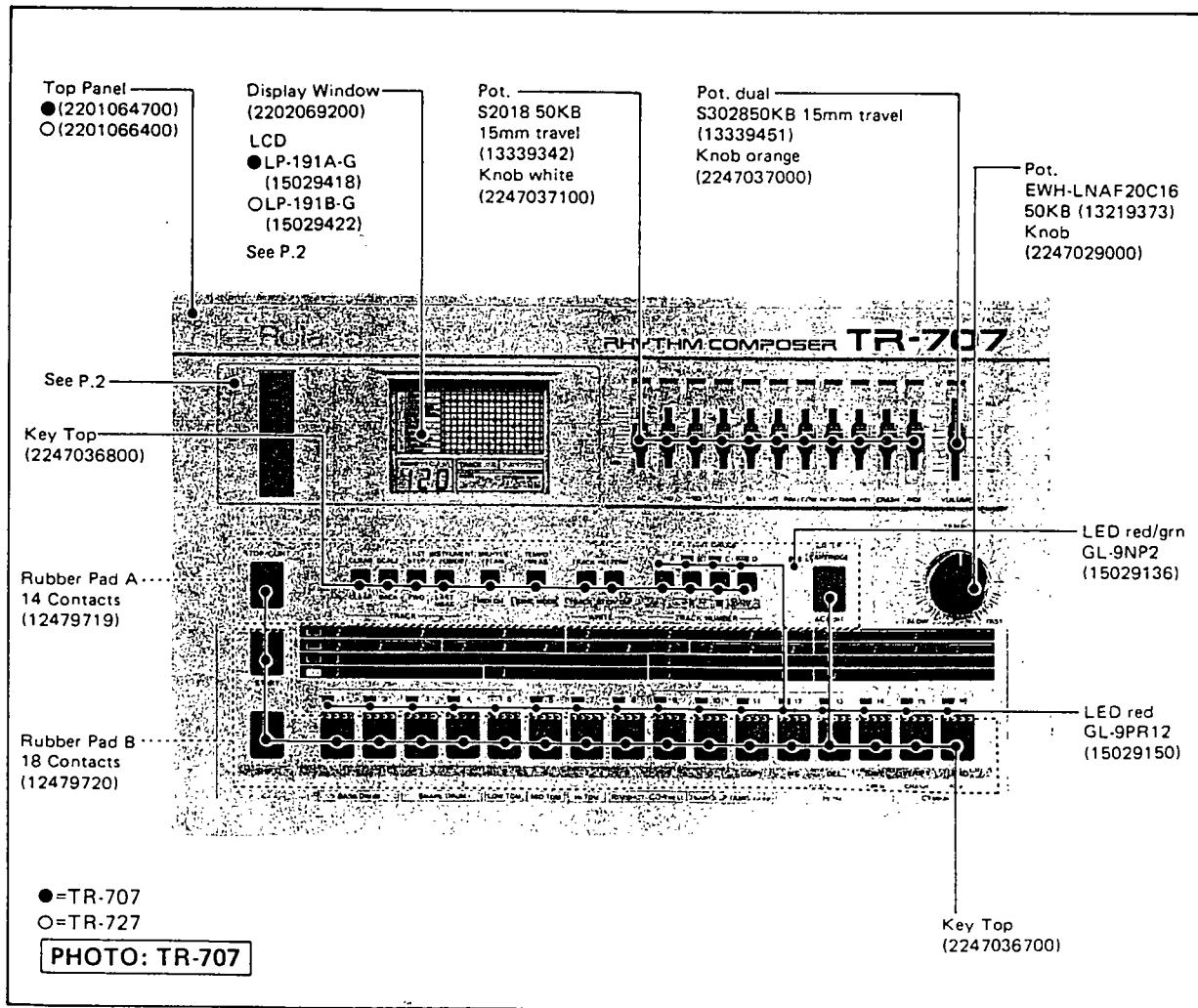

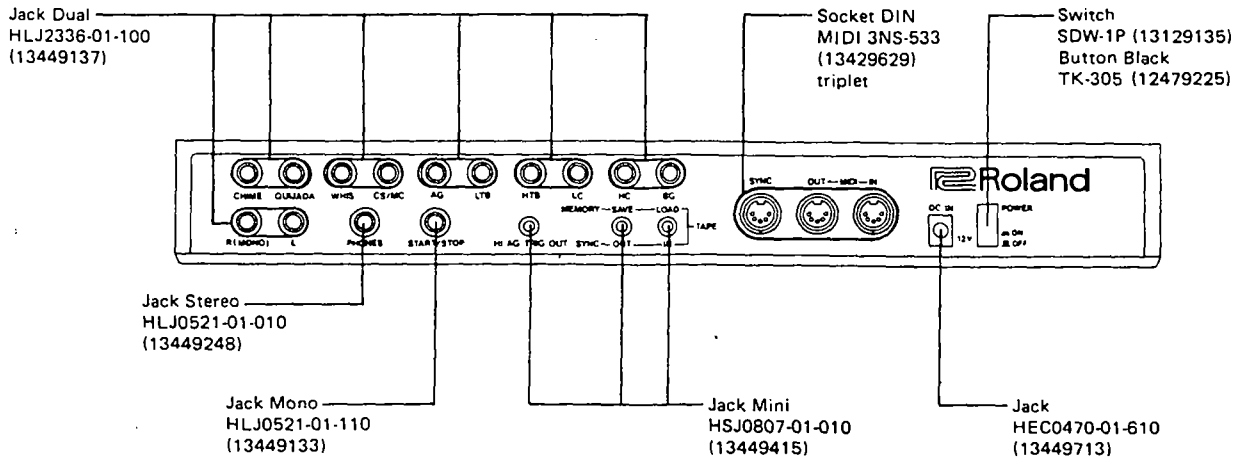

	TR-707	TR-727
<b>A</b>	Voicing Board (7313604000) (pcb 2291098102)	Voicing Board (7313804000) (pcb 2292018900)
<b>B</b>	Volume Board (7313605000) (pcb 2291098002)	Volume Board (7313805000) (pcb 2292019000)
<b>C</b>	Switch Board (7313606000) (pcb 2291097903)	
<b>D</b>	LCD Board (7313607000) (pcb 2291098203)	

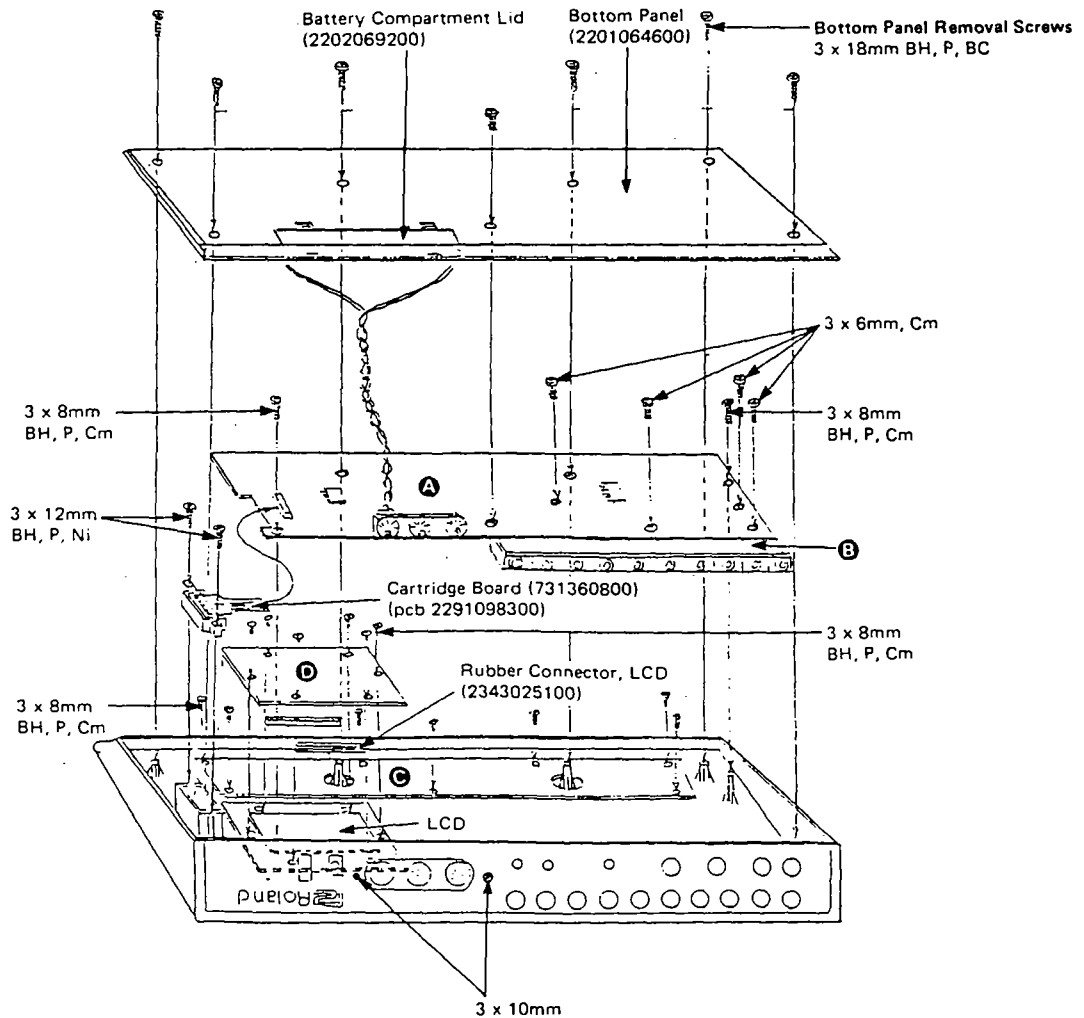

### LCD Driver HD61602

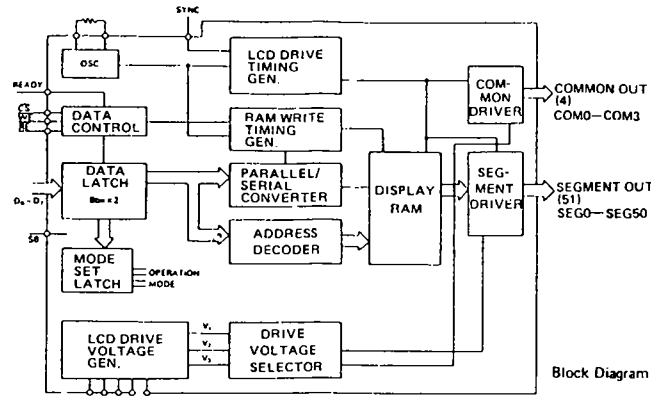

Block Diagram

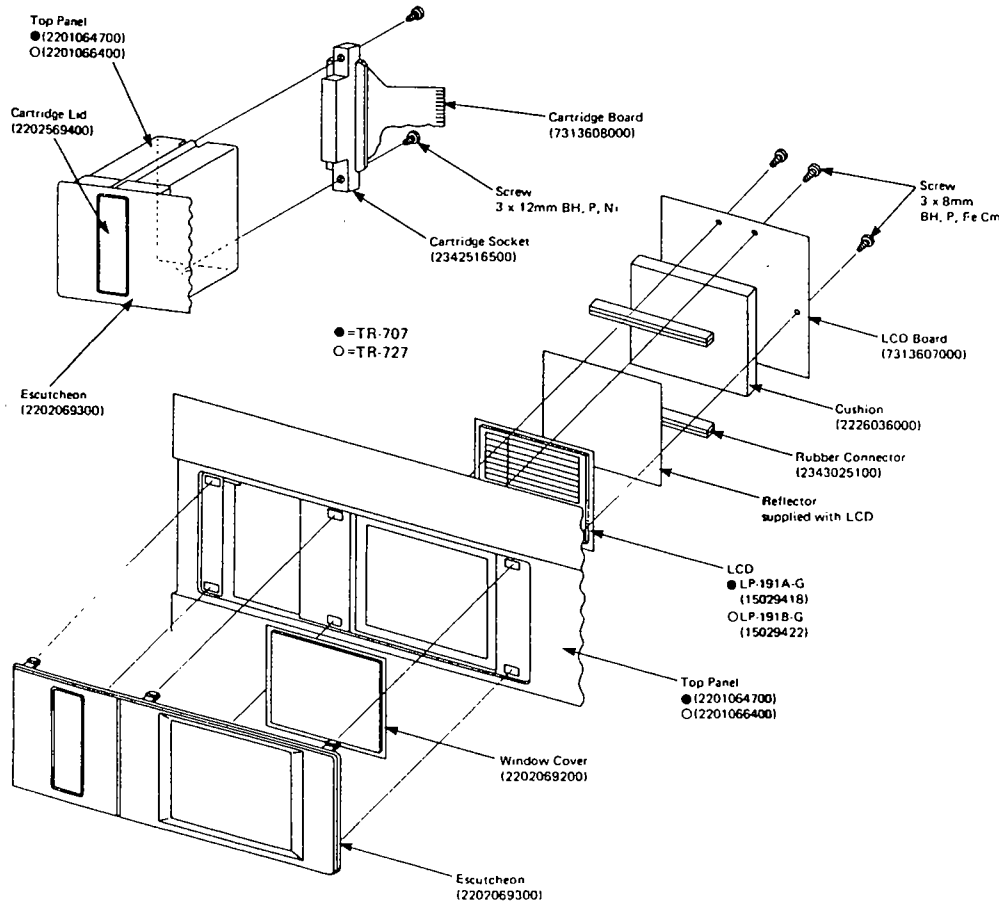

Pin configuration  
(Top View)

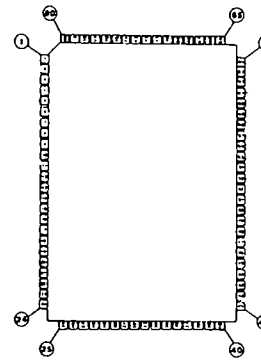

TERMINAL ASSIGNMENTS

Pin no.	Pin name	Pin no.	Pin name	Pin no.	Pin name
1	Vdd	26	SEC27	55	SEC27
2	READY	29	SEC18	56	SEC21
3	CS	30	SEC17	57	SEC26
4	FE	31	SEC16	58	SEC19
5	FE	32	SEC15	59	SEC18
6	SB	33	SEC14	60	SEC17
7	B7	34	SEC13	61	SEC16
8	B6	35	SEC12	62	SEC15
9	D5	36	SEC11	63	SEC14
10	D4	37	SEC10	64	SEC13
11	Vdd	38	SEC9	65	SEC12
12	D3	39	SEC8	66	SEC11
13	D2	40	SEC7	67	SEC10
14	D1	41	SEC6	68	SEC9
15	D0	42	SEC5	69	SEC8
16	Vref1	43	SEC4	70	SEC7
17	Vref2	44	SEC3	71	SEC6
18	VCP	45	SEC2	72	SEC5
19	VCI	46	SEC1	73	SEC4
20	V1	47	SEC0	74	SEC3
21	V2	48	SEC29	75	SEC2
22	V3	49	SEC28	76	SEC1
23	COM0	50	SEC27	77	SEC0
24	COM1	51	SEC16	78	SYNC
25	COM2	52	SEC25	79	OSC1
26	COM3	53	SEC24	80	OSC1
27	SEC50	54	SEC23		

### PARTS LIST EXCLUSIVE PARTS

#### TR-707

##### CASING

2201064700 Top Panel

##### PCB

7313604000 Voicing Board (pcb 2291098102)  
7313605000 Volume Board (pcb 2291098002)

##### LCD

15029418 LCD LP-191A-G

##### IC

##### Program ROM

15179720 HN4827128G-25 NMOS EPROM  
(Ver.0 SN460100-504399)  
(Ver.1 SN504400-519599)

or

15179660 HN613128PE95 CMOS MASK ROM  
(Ver.1 SN519600-533099)

or

15179692 HN613128PC24 CMOS MASK ROM  
(Ver.2 SN533100-up)

##### UPWARD COMPATIBILITY

Ver.0

In Pattern PLAY mode -- Selecting a pattern from different scale while repeating STOP and START or CONTINUE sometimes leads to Power-ON initialization. ROMs of Ver. 1 always run the new pattern at the beginning of a measure.

Ver.1

When the unit is used as a Master -- Repetitions of STOP and CONTINUE more than 30 times would cause generation of a redundant MIDI clock \$F8. When the unit is used as a Slave -- Will miss a MIDI IN clock when STOP signal follows the Clock within 1ms.

MASK ROM of Ver.2 cures this problem.

For a replacement Ver.2 or up is recommendable.

上記コンパチブルで補修用としてはバージョン番号の大きいPROMの使用が望ましい。

##### Sound ROM

15179661 HN61256PC-71 CMOS MASK ROM  
BD1/2, SD1/2, LT, MT  
15179662 HN61256PC-72 CMOS MASK ROM  
HT, Open/Closed H.H, Rim, Cow  
HCP, Tambourine  
15179663 HN61256PC-73 CMOS MASK ROM  
Crash Cymbal  
15179664 HN61256PC-74 CMOS MASK ROM  
Ride Cymbal

#### TR-727

##### CASING

2201066400 Top Panel

##### PCB

7313804000 Voicing Board (pcb 2292018900)  
7313805000 Volume Board (pcb 2292019000)

##### LCD

15029422 LCD LP-191B-G

##### IC

##### Program ROM

15179719 HN4827128G-25 NMOS EPROM

##### Sound ROM

15179694 HN61256PC-79 CMOS MASK ROM  
HI/LOW BONGO, HI CONGA  
LOW CONGA, HI TIMBALE

15179695	HN61256PC-80	CMOS mask ROM LOW TIMBALE, AGOGO, CABASA MARACAS, WHISTLE
15179696	HN61256PC-81	CMOS mask ROM QULJADA
15179697	HN61256PC-82	CMOS mask ROM STAR CHIME

**COMMON PARTS**

**CASING**

2201064600	Bottom Case
2202069100	Battery Cover
2202069200	Display Window
2202069300	LCD Escutcheon
2202569400	Cartridge Lid

**KNOB, BUTTON, KEY TOP**

2247029000	Knob	gray	TEMPO
2247036700	Key Top (large)	gray	Main Key 1-16, ENTER, START, SHIFT, STOP/CONT
2247036800	Key Top (small)	gray	
2247037100	Knob	white	BD, SD, LT, MT, HT, OCH, RS/CB, HCP/TAMB, RIDE, CRASH
2247037000	Knob	orange	VOLUME
12479225	TK-305	black	POWER

**PCB ASSY**

7313606000	Switch Board	(pcb 2291097903)
7313607000	LCD Board	(pcb 2291098203)
7313608000	Cartridge Board	(pcb 2291098300)

**COIL, TRANSFORMER**

2244025000	S097744	Transformer	DC/DC convertor
12449229	FKOB160MH15	Coil	line filter

**SOCKET**

13429629	MIDI 3-NS-533	DIN
13449713	HEC0470-01-610	AC adapter
13449415	HSJ0807-01-010	mini
13449248	HLJ0521-01-010	stereo
13449133	HLJ0521-01-110	monoral
13449137	HLJ2336-01-100	dual
2342516500	PBRS-28U-T01-S	cartridge

**SWITCH**

12479719	Rubber switch (Pad) A	14 contact upper row
12479720	Rubber switch (Pad) B	18 contact lower row
13129135	SDW-1P	POWER

**POTENTIOMETER**

13339342	S2018 50KB	slide 15mm travel
13339451	S3028 50KB	dual slide 15mm travel
13219373	EWL-LNAF20C16 50KB	TEMPO
13299136	RVF8P01-503 50KB	trimmer
13299141	RVF8P01-204 200KB	trimmer

**XTAL, CERAMIC RESONATOR**

12389736	HC-18/U	4.0MHz Xtal
12389735	CSA 1.6MK	1.6MHZ ceramic resonator

**IC**

15229825	RD63H114PF	gate array
15179200	HD6303XF	CPU
15179340	HM6116LP-4	CMOS S RAM
15219148	HD61602	LCD driver
15159503	TC40H000P	H CMOS
15159504	quad 2-input NAND gate TC40H002P	H CMOS
	quad 2-input NOR gate	

15159505	TC40H004P	H CMOS
	hex inverter	
15159517	TC40H010P	H CMOS
	triple 3-input NAND gate	
15159506	TC40H138P	H CMOS
	3-to-8 line decoder/demultiplexer	
15159535	TC40H151P	H CMOS
	1-of-8 data selector/multiplexer	
15159511	TC40H174P	H CMOS
	hex D-type flip flop	
15159524	TC40H245P	H CMOS
	octal bidirectional bus buffer	
15159507	TC40H273P	H CMOS
	octal D-type flip flop	
15159530	TC40H367P	H CMOS
	hex bus buffer	
15159104	TC4011BP	CMOS
	quad 2-input NAND gate	
15159105	TC4013BP	CMOS
	dual D-type flip flop	
15159141	HD14040BP	CMOS
	12-stage binary counter	
15159113	HD14051BP	CMOS
	single 8-channel multiplexer/demultiplexer	
15159301	TC4520BP	CMOS
	dual binary up counter	
15159303	HD4584BP	CMOS
	hex schmitt trigger	
15189136	M5218L	Op amp
15189154	TL064	FET Op amp
15219147	UPC624C	D/A convertor
15199108F0	UA78M05UC	voltage regulator +5V
15229712	PC900	photo coupler
15149118	M54517P	transistor array

**TRANSISTOR**

15129612	2SD1469-R	NPN
15129137	2SC2603-F	NPN
15129412	2SC1384-Q	NPN
15119125	2SA1115-F	PNP
15139101	2SK30ATM-Y	FET

**DIODE**

15019126	1SS113T-77	diode
15019209T0	S-5500G	rectifier
15019667	RD-12EB1-T	12V zener
15029136	GL-9NP2	LED red/grn
15029150	GL-9PR12	LED red

**RESISTOR ARRAY**

13919133	RKM7LM502	D/A convertor
13919103	RGSD8X103J	10K x 8
13919113	RGSD4X103J	10K x 4
13910107	RSD8X332J	3.3K x 8

**CONNECTOR**

13439256	5089-11A	11P (Switch pcb)
13439255	5089-13A	13P (Switch pcb)
13439253	5494-9C	9P (Voicing pcb)
13439252	5494-10C	10P (Voicing pcb)
13439254	5597-28APB	28P (Voicing pcb) cartridge
2343025100		rubber connector LCD

**WIRING ASS'Y**

2341048000	13P	(LCD pcb)
2341047900	11P	(Voicing pcb)
2347015200	9P flat cable	(Volume pcb)
2347015300	10P flat cable	(Volume pcb)

**MISCELLANEOUS**

2217515300	Spring	RAM cartridge
2214531300	Shaft	RAM cartridge
2345014600	Plate	battery
12469117	Heat Sink MT-25-BS	
2219049900	LED Holder	(switch pcb)
13529117	Ceramic Capacitor	D55Y5V1H334Z21 0.33µF (LCD pcb)
12559708	Fusing Resistor	FRNB 1/4W2.7Ω
2225022801	Shield Cover	top panel
2225022400	Shield	(Voicing pcb-Volume pcb)

**COMMERCIALLY AVAILABLE ACCESSORIES**

12569105	Dry cell SUM-3S	1.5V
12449538	12V AC adapter	(100V)
12449539	12V AC adapter	(117V)
12449540	12V AC adapter	(220V)
12449541	12V AC adapter	(240VA)
2343067500	Connection Cable LP-25	Australian

### TR-707/TR-727 BLOCK DIAGRAM

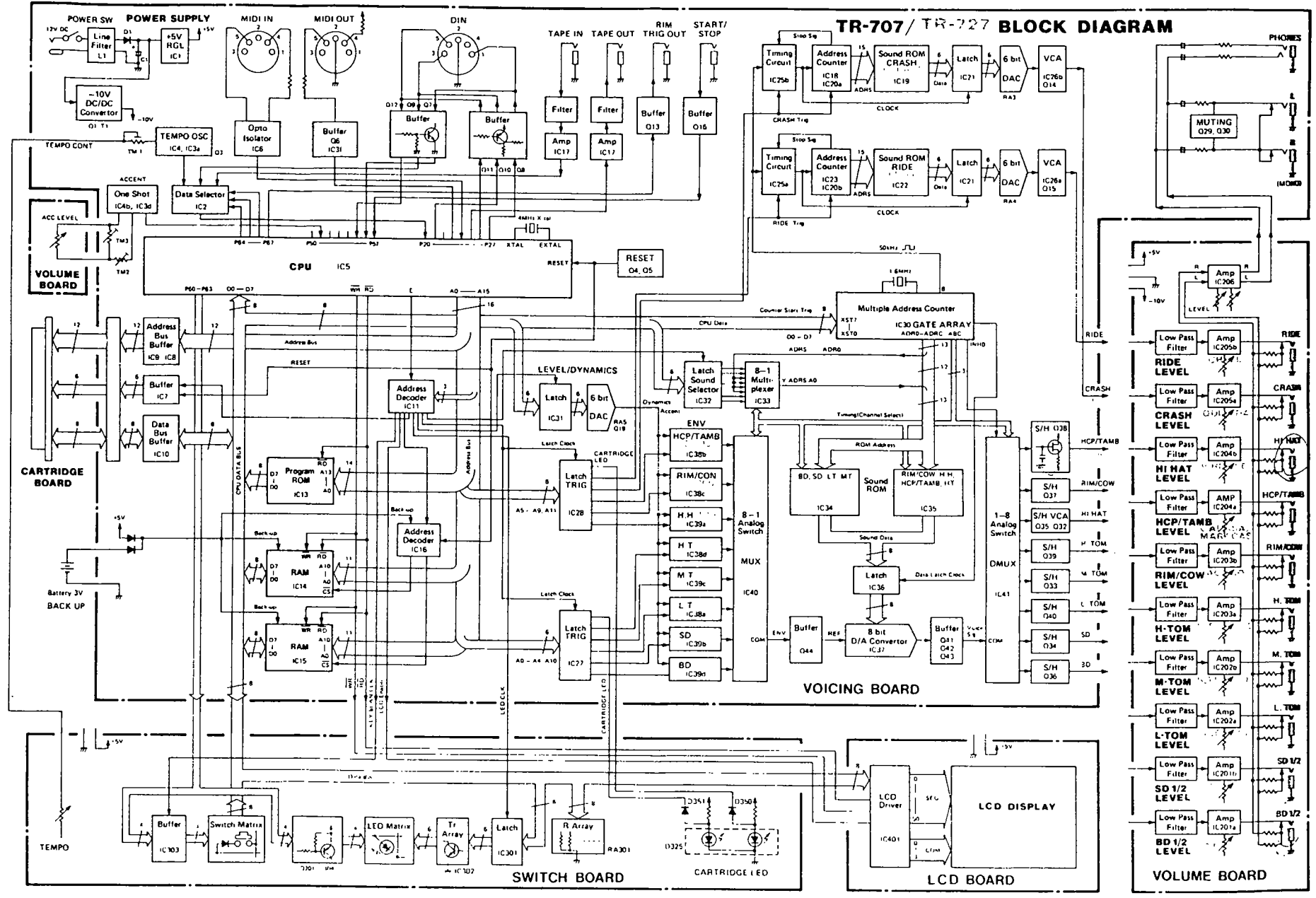

## CIRCUIT DESCRIPTIONS

TR-707 and TR-727 are designed based on the same circuit configuration, having more in common with each other. The differences between two models are sound data, component values in several audio stages and a couple of pin connections at IC30 of Voice board.

Both models derive all rhythm sounds from PCM-encoded samples of real sounds stored in ROM. Each waveform is stored either independently (e.g. CYMBAL) or together with another waveform as shown in Tables 1 and 2. Accordingly, sound reproducing circuits are classified into two: multiplex and single. The following description focuses on PCM sound reproduction system, taking TR-707 circuits as a representative.

## 回路解説

TR-707/727はROMにメモリされているPCM波形(サウンドデータ)を音源として利用しています。楽器の種類が異なる為一部に回路や定数の違いがあるものの、全体の回路構成は両機種に共通です。以下TR-707を例として説明します。

表1及び2から判る様に、IC34、IC35には複数音源のデータが、IC19、IC22ICには単一音源がメモリされています。従って、これら音源データの読み出しから再生までの過程もシングル方式とマルチの二種類があります。

## MULTIPLEX SOUND PROCESSING

### MULTIPLE ADDRESS COUNTERS

IC30 RD63H114 on Voicing Board is a custom-LSI(called Gate Array) designed for use in PCM-sound multi-rhythm systems. The LSI assumes the key role in the TR 707 sound system. It incorporates a master clock generator, timing generator and 8 13-bit address counters. The timing generator, not only supplies clocks to these counters for generating address bits, but also feeds peripheral circuits with various timing clocks to sync the entire system operation. Of these timing clocks, A, B and C together make a channel-select code for signaling the ROMs (ICs 34, 35), MUX IC40 and DMUX IC41 which voice is being addressed by an address counter in IC30.

## マルチ音源

### マルチアドレスカウンタ

多音源データをメモリしているROM(IC34,35)からのデータ読み出し、D/A変換、S/Hおよびその他の関連回路は、IC30 RD63H114をマスターとして動作します。RD63H114はマルチ音源機器用に開発されたカスタムLSIであって、内蔵のクロックおよびタイミング発生回路によりこれら外付回路を同期させるクロック信号を出力します。同期クロックのうちA、B、Cはボイス・チャンネルのセレクトコードを形成しますので特に重要です。IC30はROM(IC34,35)内の各音源データのアドレスを次々と出力して行きますが、A、B、Cは今日の音源アドレス(アドレス・カウンタのチャンネル番号)が出力されているかを、ROM以外のMUX IC40、DMUX IC41にも知らせます。(例SDの場合A=1、B=0、C=0。次頁のタイミングチャート参照)

MULTIPLEX SOUND SYSTEM BLOCK DIAGRAM

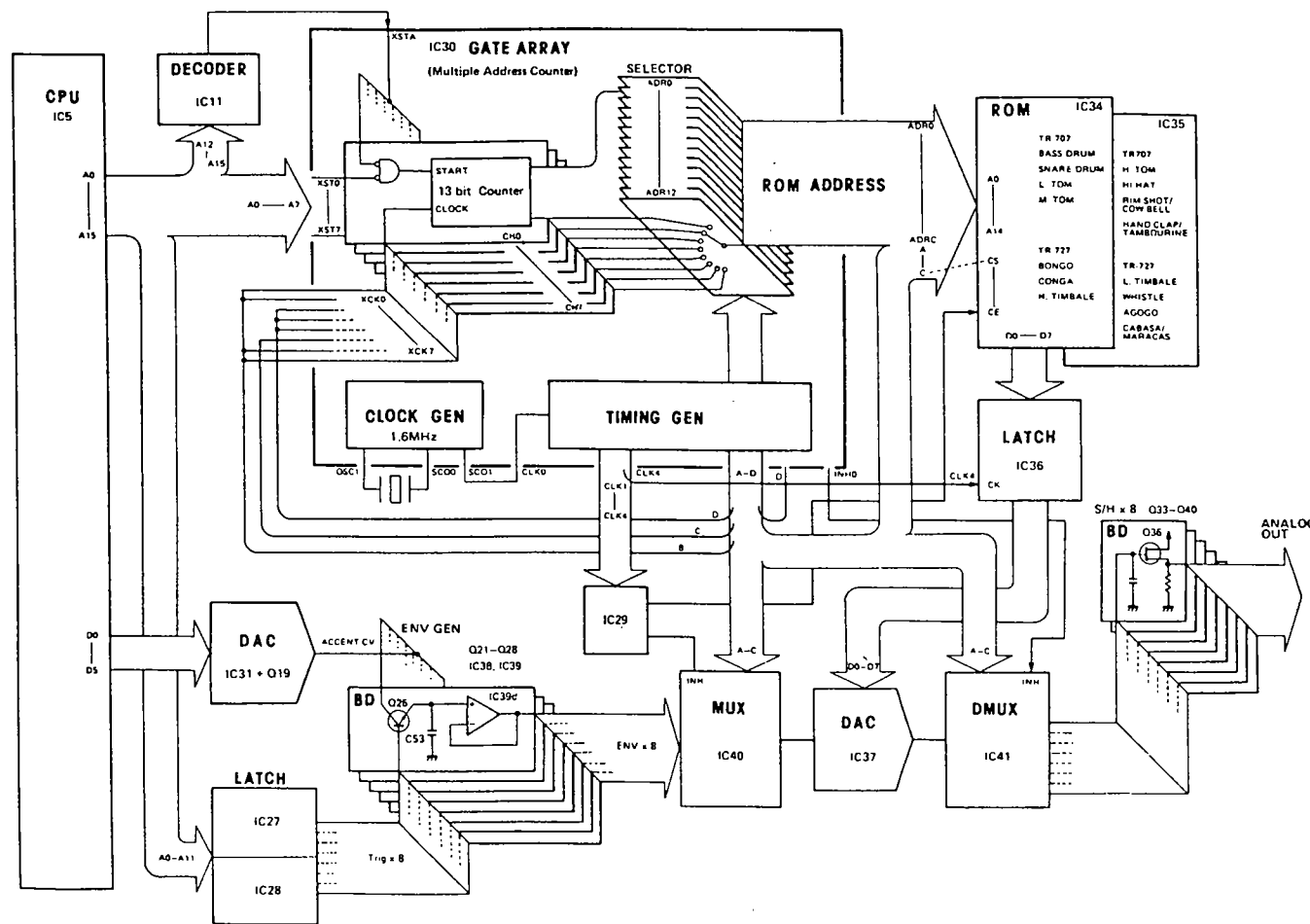

Now suppose that TR-707 is to run with BASS DRUM 1(BD-1) being selected, the CPU IC5 puts XST0 (CH0 start) and XSTA (XST0-XST7 enable) low, resetting counter 0, presetting it to the clock pulse 0000H and allowing it to count the clock pulse XCK0 from pin B in discrete steps. The counter continues counting until it increments up to 1FFFFH and tops there until the next trigger pulse is received. While counting, the contents (a group of 13 clock pulses) of the counter is transferred to address selector where it is read every 40μs and is presented along ports ADRO through ADRC--13 lower address bits.

ROM: MEMORY READING

IC34 and IC35, 32,768 word by 8 bit ROM, require 15 address bits to access their memory locations. Clocks A and B from IC30 serve as MSBs while C indicates which one of two ROMs is to be selected--Chip Select.

On the contrary, LSB ADRO is defeated when particular voice is selected: BD-1 and BD-2 share the same memory area with even addresses allocated to BD-1 and odd ones to BD-2 as shown in Table 1. With BD-1, data selector IC33 blocks ADRO and passes "0" data from IC32 onto AD of ROM IC35. With BD-2, IC33 selects "1". With Low Tom, Mid Tom, Hi Tom or Hi Hat, ADRO is allowed to reach A0.

Each 8-bit memory location (PCM waveform data) in ROM is loaded into latch IC36 on the rising edge of CLK4. This 8 bit data is, if converted to analog equivalent by D/A converter IC37 as it is, not restored to its original amplitude. A certain technic is involved during PCM to improve S/N ratio, to have higher resolution, etc. A signal coming from Envelope Generator into (+) REF pin gives right tone contour to a continual PCM waveforms being decoded and converted to an analog sound.

今 BASS DRUM1 (BD-1)が選択された状態で、リズムが走ったとすると、IC30にXST0(チャンネル0スタート)とXSTA(XST0-7イネーブル)が加わり、カウンタCH0は0000Hにリセットされた後XCK0に追加されて来るクロックBをカウントして行きます。この13ビット・アドレスカウンタのカウント値は40μs毎にアドレス・セレクタによりADRO-ADRC端子に出力されて行きます。(次にもう一度XST0が加わらない場合、カウンタは最大値1FFFFHに達するとストップしたままとなります。)

サウンド・データの読み出し

256KビットROM IC34, IC35のメモリ・ロケーションにアクセスするには、15ビットのアドレスが必要です。残りのMSB2ビットにはIC30のA、Bクロックが当てられます。クロックCは、どちらのROMにアクセスするかを選ぶチップ・セレクタです。一方LSB ADROは、音源によってはROMアドレスとして使用されません。例えば、BD-1とBD-2は同じROMのメモリ・エリアを共有しており、BD-1には偶数のアドレスがBD-2には奇数アドレスが割当てられています。(表1参照)。この為、BD-1の場合、ROMのA0には常に"0"がIC32, IC33を通じて加えられます(BD-2の場合は"1")。

ROMから読み出されたサウンド・データは、IC37(ラダー・ネットワーク内蔵)でアナログ電圧に変換されリズム音波形の一部(サンプリング波形)を再現しますが、振幅値は原音の値とは必ずしも一致しません。これはPCMの過程においてS/N比や分解能向上の処理が含まれている為です。再生音のエンベロープは、IC37の(+)REFに流れ込むENV GENからの信号によって左右されます。

TR-727 Sound Data ROM					
IC NO.	ROM	CE	CS	VOICE	MEMORY
IC34	8061256PC71 (15179694)	H	L	HI BONGO	2H ADRES 4k byte
				LOW BONGO	2H + 1 ADRES 4k byte
				MUFF HI CONCA	2H ADRES 4k byte
				OPEN HI CONCA	2H + 1 ADRES 4k byte
				LOW CONCA	2H ADRES 4k byte
				HI TIMBALE	2H ADRES 4k byte
IC35	8061256PC80 (15179695)	H	H	LOW TIMBALE	2H ADRES 4k byte
				WHISTLE	2H ADRES 4k byte
				MI AGOGO	2H ADRES 4k byte
				FINM AGOGO	2H + 1 ADRES 4k byte
				CABASA	2H ADRES 4k byte
				MARACAS	2H + 1 ADRES 4k byte

TR-707 Sound Data ROM					
IC NO.	ROM	CE	CS	VOICE	MEMORY
IC34	8061256PC71 (15179691)	H	L	BASS DRUM 1	2H ADRES 4k byte
				BASS DRUM 2	2H + 1 ADRES 4k byte
				SHARE DRUM 1	2H ADRES 4k byte
				SHARE DRUM 2	2H + 1 ADRES 4k byte
				LOW TOM	2H ADRES 4k byte
				MID TOM	2H ADRES 4k byte
				HI TOM	2H ADRES 4k byte
				HI HAT	2H ADRES 4k byte
IC35	8061256PC72 (15179692)	H	H	RIM SHOT	2H ADRES 4k byte
				CON BELL	2H + 1 ADRES 4k byte
				HAND CLAP	2H ADRES 4k byte
				TAMBOURINE	2H + 1 ADRES 4k byte

Table 1 表1

TIMING CHART タイミング・チャート

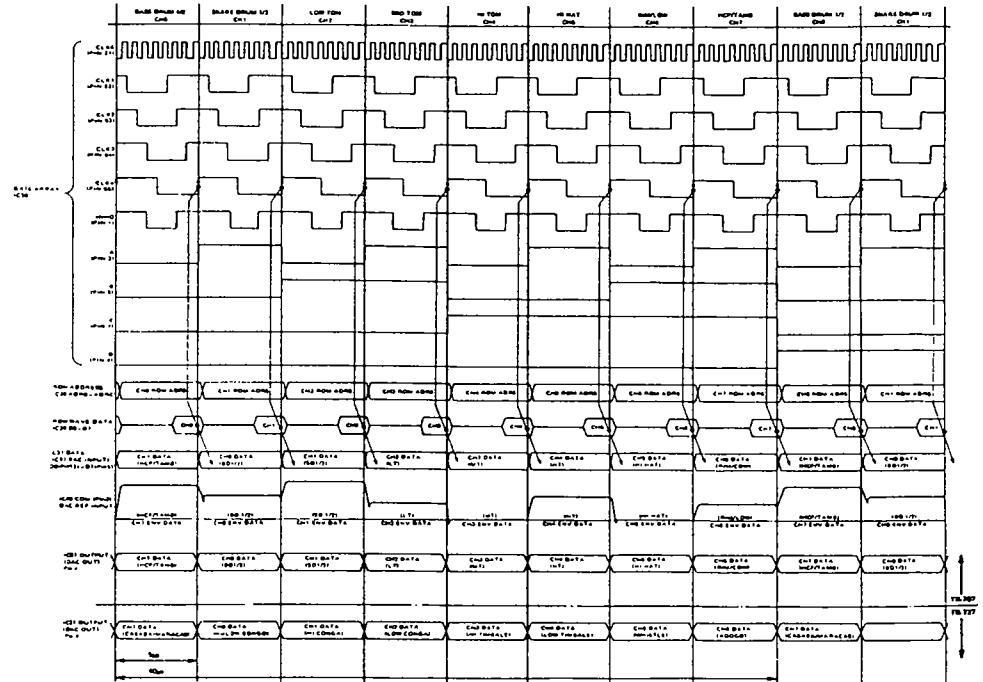

ENVELOPE GENERATOR

Data coming to latch IC31 is a combination of LEVEL and DYNAMICS (ACCENT). The value of LEVEL is always constant regardless of voice selected, while DYNAMICS varies with MIDI Velocity or ACCENT amount setting.

Although LEVEL/DYNAMICS is connected to all 8 ENV GENERATORS it is allowed to enter only the transistor whose base-emitter junction, for example Q26, is being forward biased by a TRIG from latch IC27 or IC28 at XSTA rate. Q26 output is then connected by IC40 to (+) REF pin of IC37 every 40μs with its level decaying according to C53xR59 time constant as the successive BD-1 data are converted to analog voltages, giving a bass drum contour to the voice.

The DAC output is boosted at Q41 and Q42 conjunction and is channeled into the S/H which is designated by A B C code placed at IC41 select pins.

As can be seen from the timing chart, the timing of enveloping and D/A converting lag one slit behind the memory addressing. That is, BD-1 sound read from ROM with channel No. ABC=000 becomes an audible sound when channel No. is represented by ABC=100. This is because the data accessed on a positive going CLK4 with ABC=000 is latched into IC36 on the next CLK4 with ABC=100. Consequently, TRIG data to ICs 27 and 28, and LEVEL/DYNAMICS data to IC31 are made to delay one CLK4 cycle to keep pace with D/A conversion at IC37.

エンベロープ・アクセント

XSTA (XST0-7イネーブル)はIC30のアドレスカウンタに加えられると同時に、ラッチIC27, 28のCLKにも加えられ、BD-1が選択されている時には、ENV GENのQ26がTRIGパルスによって導通し、LEVELとDYNAMICS(ACCENT)の混合された電圧がC53に充電されます。なお、LEVELの値はどの音源の場合でも常に一定です。また、LEVEL/DYNAMICS CVは8本全てのトランジスタに印加されますが、TRIGパルスが現在加わっているトランジスタのみに流入します。Q26の出力はIC39dを通り、IC40により時分割でD/AコンバータのREF端子へ送られて行きますが、振幅はC53xR96の時定数に応じて減衰して行きます。時定数はBDのサウンド・データ全部がROMから読み出される時間より長くなる様に設定されています。

注 IC30のアドレス・カウンタのチャンネル番号とIC40/41のチャンネル番号が異なっています。これはROMのサウンド・データが、アクセスされた時よりCLK4の1サイクル分遅れてIC36にラッチされD/A変換される為です。したがってTRIGおよびLEVEL/DYNAMICSデータもその分遅れて出力されます。

**HI HAT**

Output from Q35 has no distinction between closed hi hat and open hi hat and is given a particular waveshape (decay) at VCA Q22 and IC42 as OPEN/CLOSED select signal is applied on the base of Q21.

**SINGLE SOUND PROCESSING**

Each of CYMBAL voices (RIDE and CRASH) has dedicated sound ROM, address counter, D/A converter and envelope generator. The difference from Multiplex processing in circuit configuration is that envelope control is accomplished after the wave data becomes analog form. LEVEL/DYNAMICS (ACCENT CV) routed to Q18 emitter (CRASH) is charged into envelope capacitor C50 on a TRIG, giving a contour to CRASH sound passing through Q14.

TR-707 Sound ROM

IC NO.	ROM	CE	CS	VOICE	MEMORY
IC19	HN61256PC73 (15179663)	H	L	CRASH CYMBAL	32k byte
IC22	HN61256PC74 (15179664)	H	L	RIDE CYMBAL	32k byte

Hi Hat に対しては、もう一度エンベロープ回路(VCA-IC42a, Q32)が追加されており、クローズかオープンかによりディケイタイムを切替えています。

**シングル音源**

RIDE CYMBAL および CRASH CYMBAL は、それぞれ専用のアドレス・カウンタ、ROM および D/A コンバータを持っていますが動作原理はマルチ音源の場合と変わりません。ただし、エンベロープがD/A変換後VCAに加えられる点の違いがあります。

TR-727 Sound ROM

IC NO.	ROM	CE	CS	VOICE	MEMORY
IC19	HN61256PC81 (15179696)	H	L	QUIJADA	32k byte
IC22	HN61256PC82 (15179697)	H	L	STAR CHIME	32k byte

Table 2 表2

**TESTING AND ADJUSTING**

The built-in test program executes the following test and adjusting routines while in Test Mode.

**RUNNING TEST PROGRAM**

While holding down CLEAR and INSTRUMENT, switch the power ON. The unit is now in the test mode and the test program initiates test routines with TEST 1.

**TEST 1. LED SEQUENTIAL LIGHTING**

Upon entering test mode the program lights up LEDs, starting with MAIN KEY 1 through SCALE INDICATOR, PATTERN GROUP and CARTRIDGE (red and green alternately) and repeats.

Leave the LEDs lighting and go to TEST 2.

**TEST 2. ALL LEDs AND LCD DOTS LIGHTING**

Press ENTER and verify lighting of all LEDs and LCD dots.

Leave them lit and go to TEST 3.

**TEST 3. SWITCHES AND ACCENT AMOUNT READING**

Press ENTER. All LCD display will be cleared OFF. Referring to the illustration below, push numbered buttons 1-32 one by one and check for the lighting of corresponding dot on either Bass Drum (BonGo) or Snare Drum (Hi Conga) row on the display window.

Slide up or down ACCENT and verify that TEMPO MEASURE window reads 1 and 16 at the extremities of travel.

**テストおよび調整**

TR-707, TR-727 には回路機能チェックおよび調整のプログラムが内蔵されています。このプログラムを走らせるにはテストモードに入る必要があります。

**テストモード**

CLEAR と INSTRUMENT ボタンを同時に押しながら電源をオンするとテストモードとなり、テスト 1 が自動的に実行されます。

**テスト 1 LED 順次点灯**

テストモードに入ると、メインキーの 1 から順次 LED が点灯して行きます。CARTRIDGE の LED は赤と緑が交互に点灯します。

LED の点灯はくり返されますが、そのままの状態でもテスト 2 へ進んで下さい。

**テスト 2 LED および LCD 全点灯**

ENTER を押します。全ての LED および LCD 上の全ドットが点灯する筈です。

そのままの状態でもテスト 3 へ進んで下さい。

**テスト 3 スイッチおよびアクセントレベル読み込み**

ENTER を押すと LCD のドットが消えます。パネル上のスイッチを押すと、右図に示す様に、対応した番号のドットが LCD の上に表示されます。



If not verified, go to ACCENT AMOUNT ADJUSTMENT below without exiting the test mode.

When all tests are satisfactory, turned the power off and on again to return to the normal operation mode (if necessary).

### ACCENT AMOUNT ADJUSTMENT

This test must be carried out in the test mode and follow the tests above.

1. Set ACCENT at MIN and adjust TM2 of VOICING board for a transition point of "1" to/from "2" of TEMPO MEASURE display reading.
2. Set ACCENT at MAX and adjust TM3 for a transition point of "15" to/from "16" of TEMPO MEASURE display reading.

The unit will remain in the test mode until the power is turned OFF.

### TEMPO CLOCK RATE ADJUSTMENT

This adjustment must be done in the normal operation mode.

1. Set TEMPO at FAST and adjust TM1 of VOICING board for 250 reading on TEMPO MEASURE window.

次に、アクセント（AC）つまみを上下させるとLCDのTEMPO/MEASURE部に数字が表示されます。MINの位置で"1"、MAXで"16"とならない場合は、次のアクセントレベル調整へ進んで下さい。

調整が不要で、通常モードに戻るには一旦電源をオフして下さい。

### アクセントレベル調整

本調整はテストモードで行ないます。上記のテストの後で行なって下さい。

1. アクセント（AC）をMINにセットし、TM2（ボイスンク基板）でTEMPO/MEASUREの表示が"1"か"2"になる臨界点に調整します。
2. ACをMAXにセットし、TM3で表示が"15"か"16"になる臨界点に調整します。

### テンポ調整

本調整は通常モードで行ないます。テストモードになっている場合は、一度電源をオフして下さい。

TEMPOをFASTにセットし、TM1（ボイスンク基板）でTEMPO/MEASUREの表示が250になる様調整します。

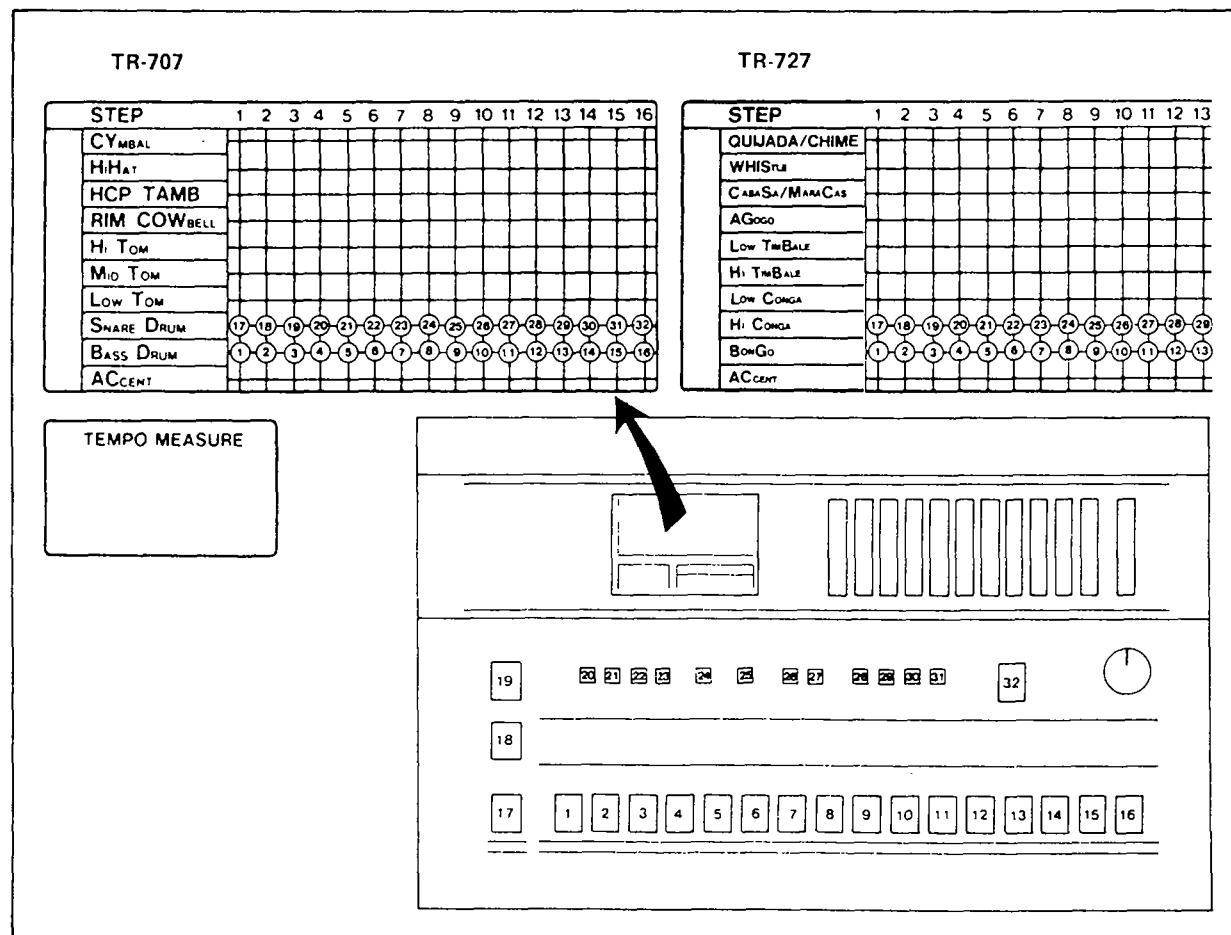

2 3 4 5 6 7 8 9 10 11 12 13 14 15 16 17 18 19 20 21 22 23 24 25 26 27 28 29 30 31 32 33 34 35 36 37 38 39

# TR-707/TR-727 GENERAL CIRCUIT DIAGRAM

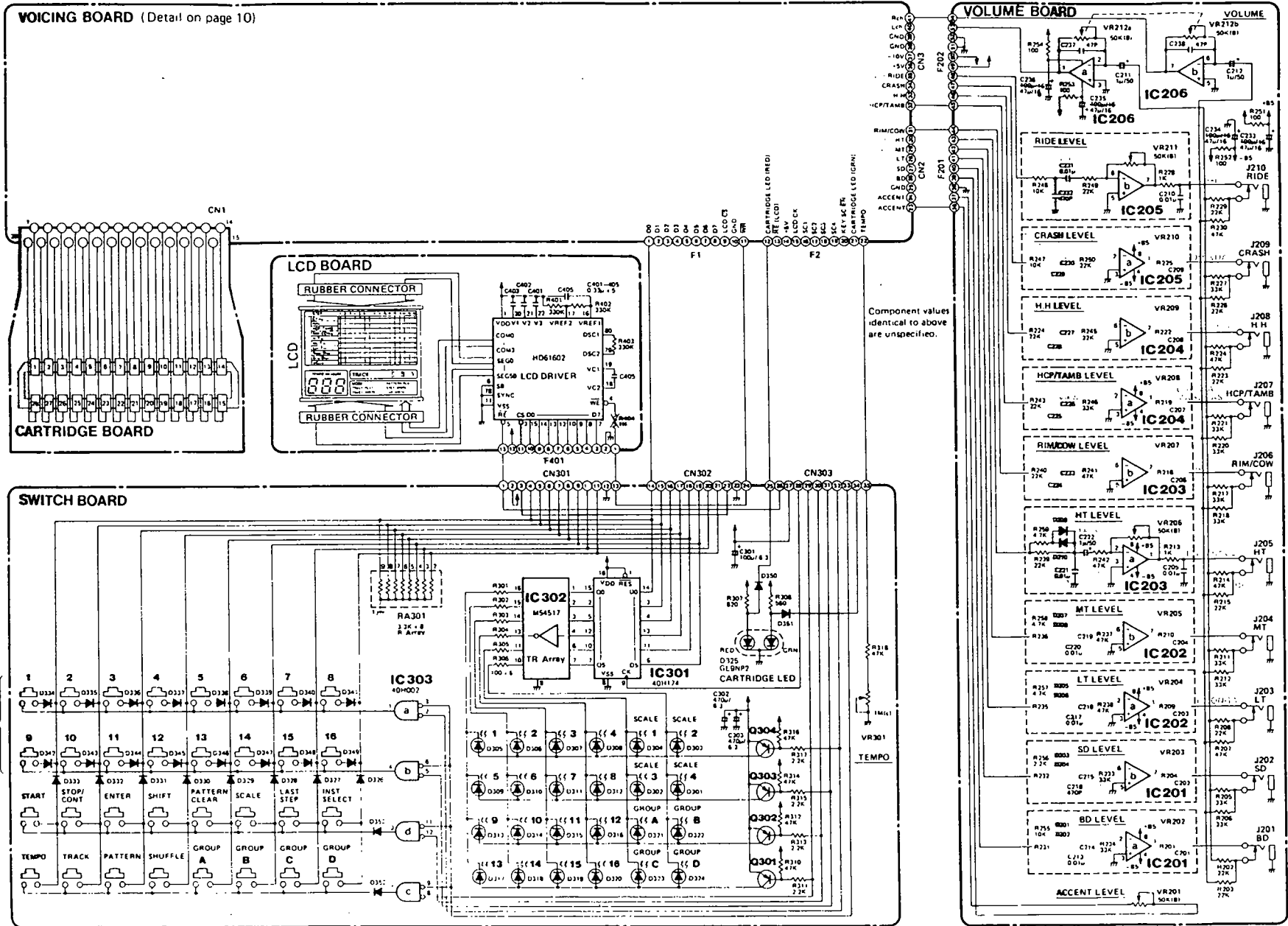

### VOLUME BOARD

TR-707 7313605000 (pcb 2291098002)

TR-727 7313805000 (pcb 2292019000)

View from foil side

### BELOW PCB LAYOUT For TR-707

TR-727's: identical to TR-707's except for those represented in red in the circuit diagram left.

下の基板図はTR-707用です。

TR-727の場合は回路図の赤線表示に従って相違点を確認して下さい。

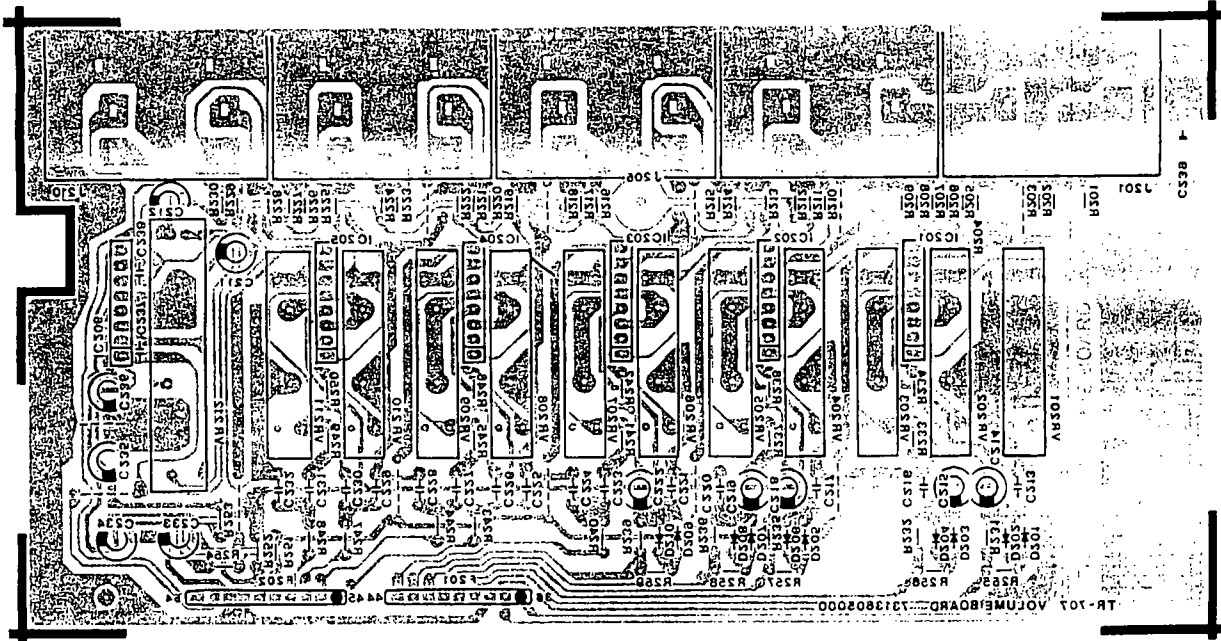

### SWITCH BOARD

7313606000 (pcb 2291097903)

View from foil side

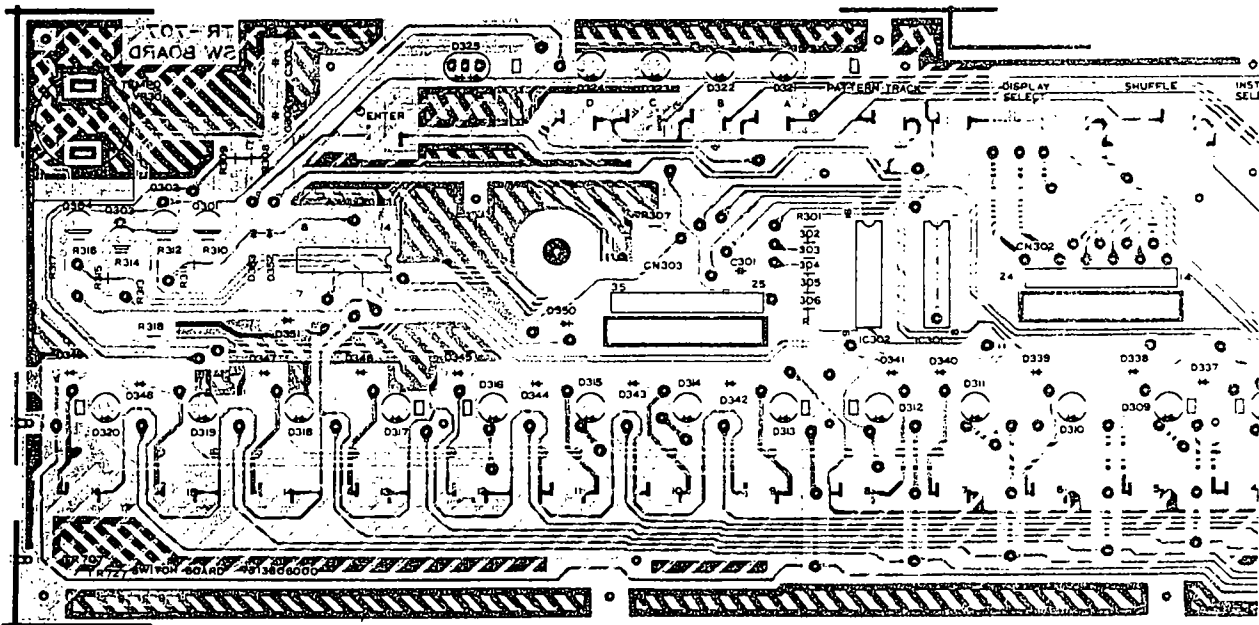

UT For TR-707

R-707's except for those represented in red  
diagram left

緑表示に従って相違点を確認して下さい。

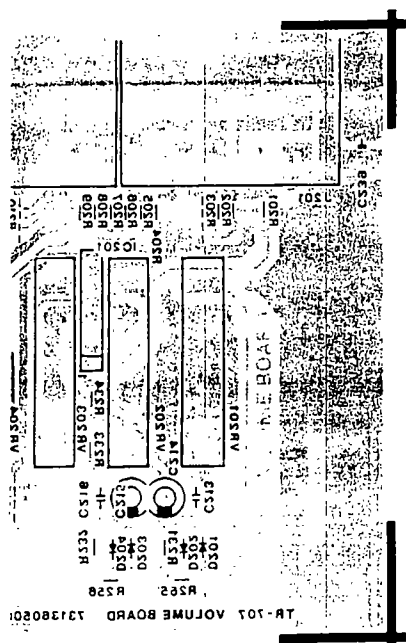

## LCD BOARD

7313607000

(pcb 2291098203)

View from foil side

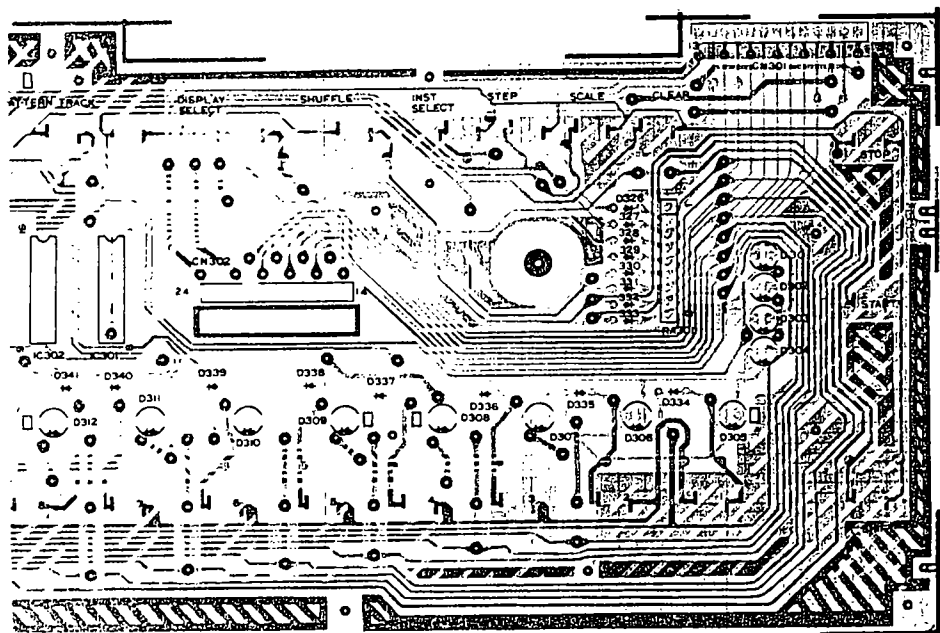
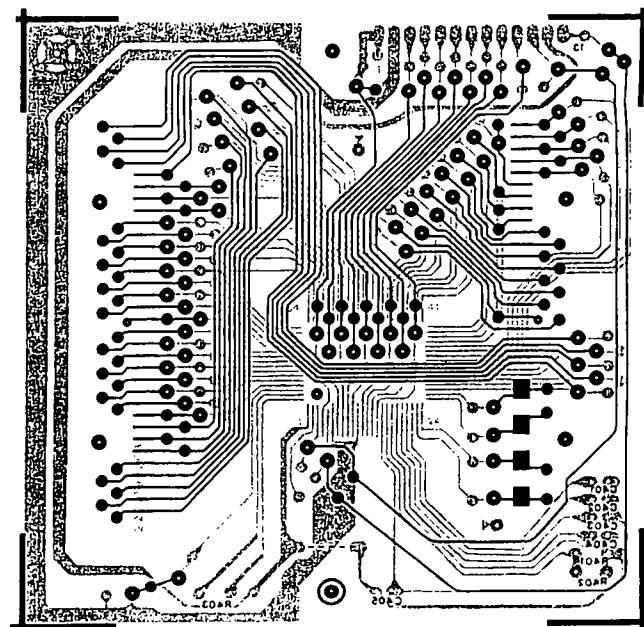

1 2 3 4 5 6 7 8 9 10 11 12 13 14 15 16

A  
B  
C  
D  
E  
F  
G  
H  
I  
J  
K  
L  
M  
N  
O  
P  
Q  
R  
S

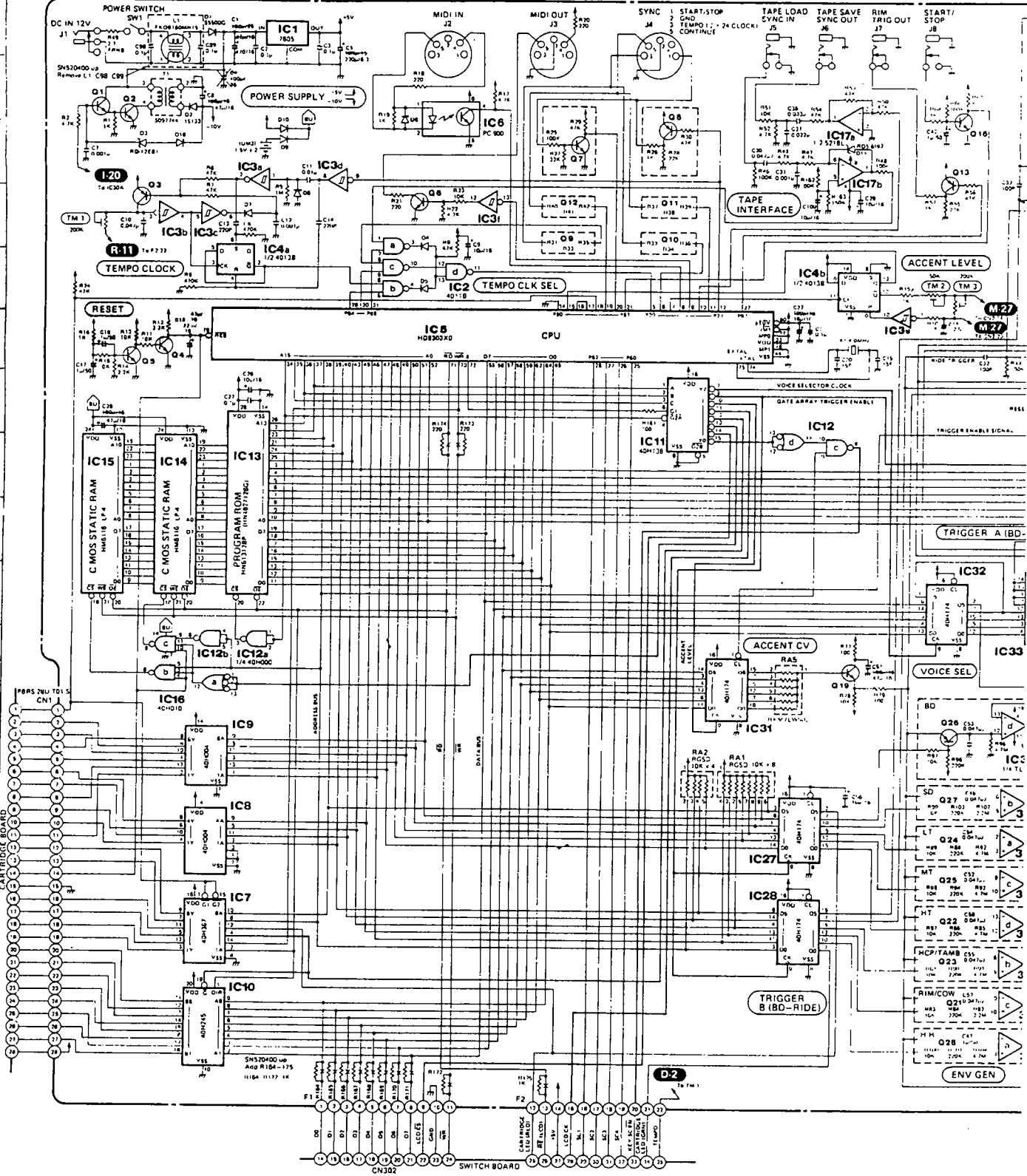

12 13 14 15 16 17 18 19 20 21 22 23 24 26 27 28

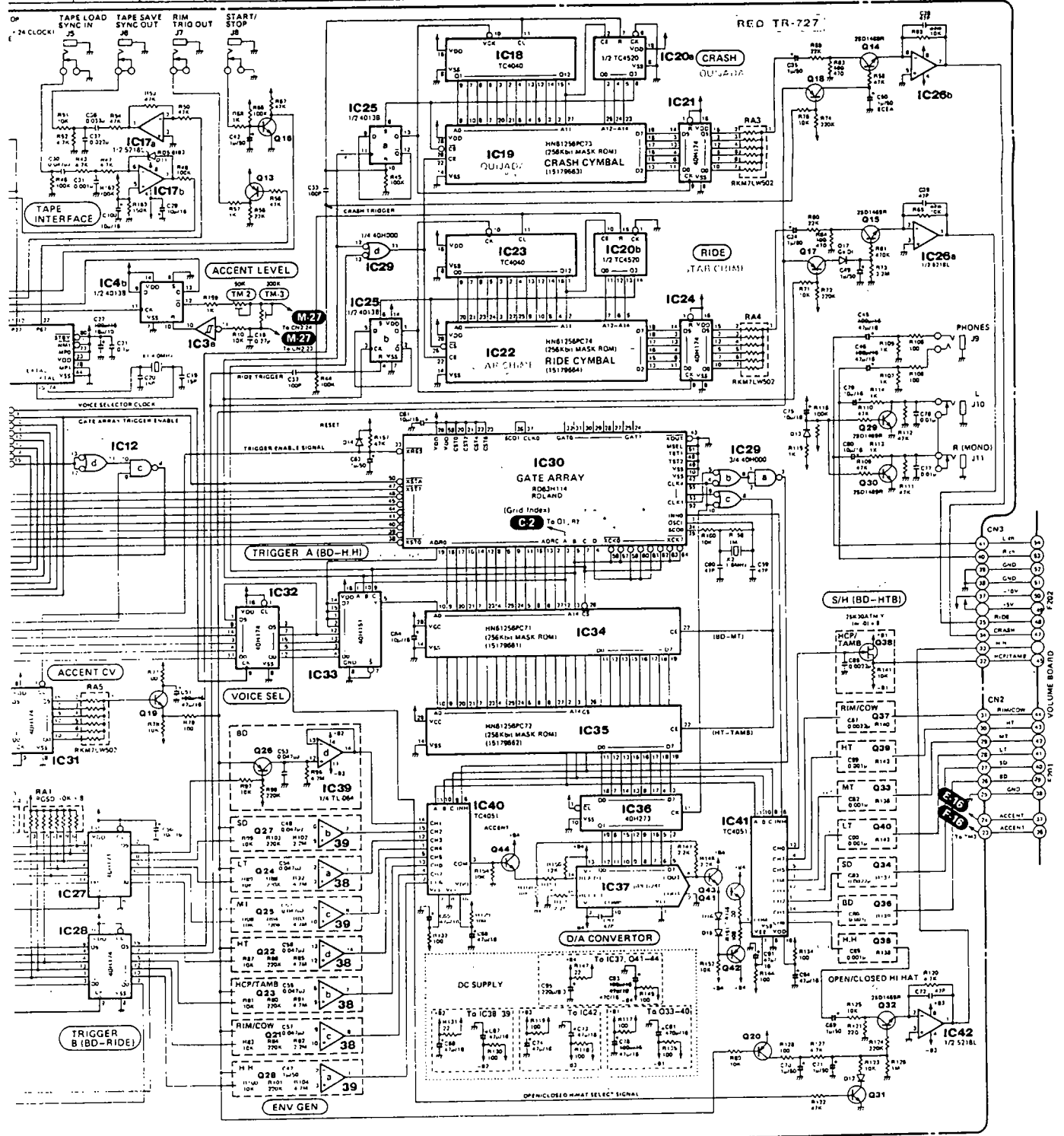

# VOICING BOARD

**TR-707** 7313604000 (pcb 2291098102)  
**TR-727** 7313804000 (pcb 2292018900)

BELOW PCB LAYOUT For TR-707  
TR-727's: identical to TR-707's except for those represented in red  
in the circuit diagram left.

下の基板図はTR-707用です。  
TR-727の場合は回路図の赤線表示に従って相違点を確認して下さい。

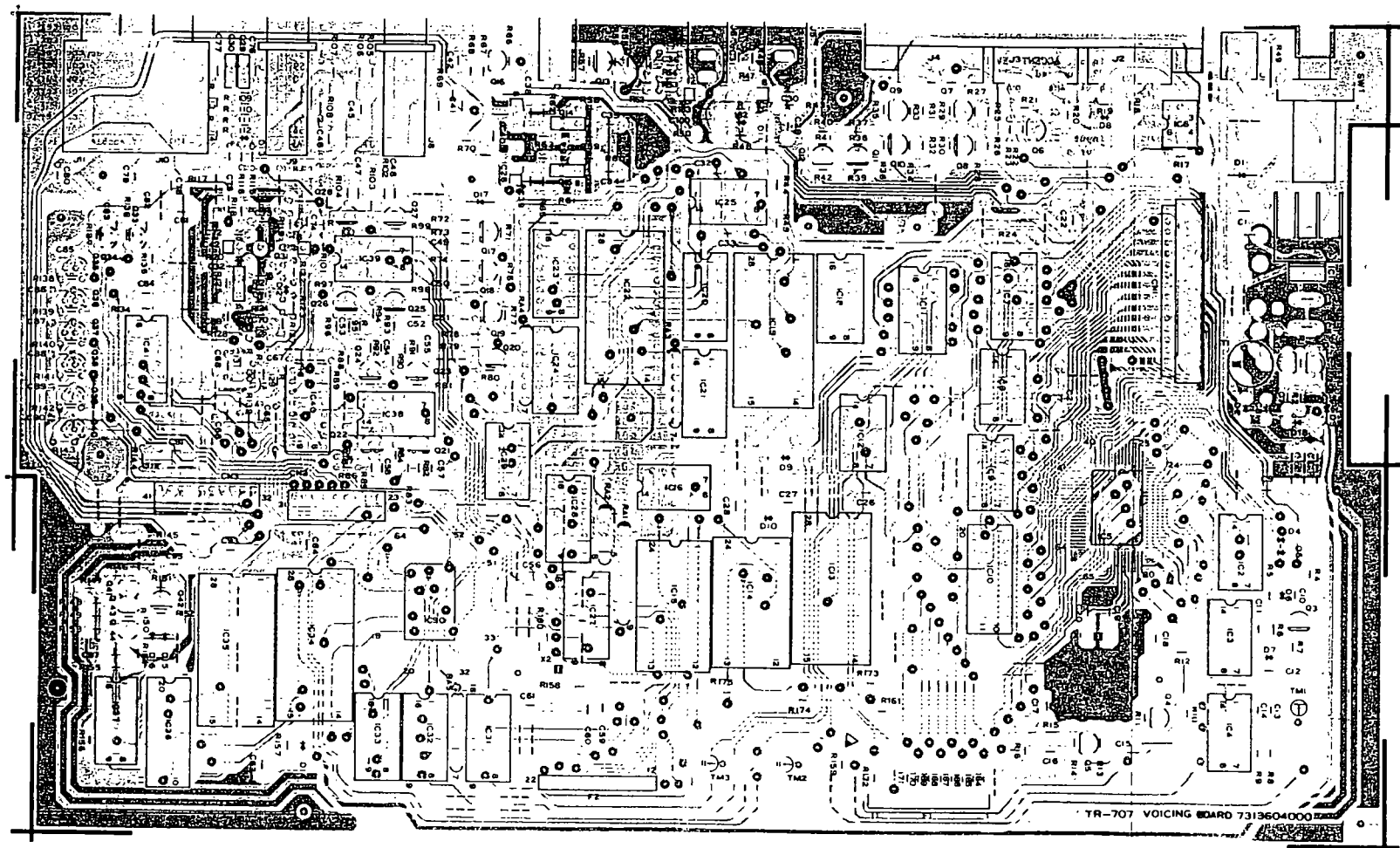

View from foil side

IC DATA

**CPU HD6303X**

Pin Configuration (Top View)

Port Assignment

PIN NO.	PORT NAME	DESCRIPTION
1	NMI	Unused, pulled up +5V
2-4	NC	Unused, open
5	P20	input, TEMPO CLOCK
6	P21	output, TEMPO CLOCK (DIN)
7	P22	output, ACCENT LEVEL input trigger for internal ADC
8	P23	input, MIDI IN
9	P24	output, MIDI OUT
10	P25	output, TAPE SYNC
11	P26	output, CONT START (DIN)
12	P27	output, START/STOP (DIN)
13	NC	unused, open
14	P50	IRQ1 unused, pulled down
15	P51	IRQ2
16	P52	input, ACCENT LEVEL
17	P53	MR unused, pulled up +5V
18	P54	HALT unused, pulled up +5V
19	P54	RAM cartridge control
20	P55	input, CONT START (DIN IN)
21	P56	input, START/STOP (DIN IN)
22-24	NC	unused, open
25-28	P60-P63	output, scanning signal to LED and KEY
29	P64	output, internal TEMPO CLOCK
30	P65	output, DIN SYNC TEMPO CLOCK
31	P66	output, TAPE SYNC TEMPO CLOCK
32	P67	output, Trigger (RIM SHOT:TR-707)(HL AGOCO:TR-727)
33	Vcc	input, +5V power supply
34-40	A15-A9	output, address A15---A9
41-42	NC	unused, open
43	AB	output, address A8
44	Vss	GND
45-52	A7-A0	output, address A7---A0
53-54	NC	unused, open
55-59	D7-D3	data bus D7---D3
60-61	NC	unused, open
62	D2	data bus D2
63	NC	unused, open
64-65	D1-D0	data bus D1---D0
66	BA	output, unused
67	LTR	output, unused
68	NC	unused, open
69	R/W	output
70	WB	output
71	RD	output
72	E	output, system clock 1MHz
73	Vss	GND
74	XTAL	terminal, Xtal
75	EXTAL	terminal, Xtal or external system clock in
76	NC	unused, open
77	MPO	input, MCU mode setting pulled up +5V
78	MPI	input, MCU mode setting pulled down GND
79	RES	input, MCU reset (active low)
80	STBY	unused, pulled up +5V (active low)

**μPC624C**

Pin Configuration (Top View)

Block Diagram

**GATE ARRAY RD63H114**

Pin Configuration (Top View)

Multiple Address Counters

DESIGNATION	PIN	DESCRIPTION	I/O	
CST	0	20		
	2	21	pulled up (+5V)	
	4	22		
	6	23		
XST	A	30	XST0-XST7 enable, active low	
	0	38		counter 0
	1	39		counter 1
	2	40		counter 2
	3	41		counter 3
	4	44		counter 4
	5	45		counter 5
	6	46	counter 6	
	7	47	counter 7	
ICK	0	56	counter 0	
	1	57	counter 1	
	2	59	counter 2	
	3	60	counter 3	
	4	61	counter 4	
	5	62	counter 5	
	6	63	counter 6	
	7	64	counter 7	
XOUT	43		address(ADRO-ADRC) out enable, active low; high-HI z	
ADR	0	19	ROM ADDRESS	
	1	18		
	2	17		
	3	15		
	4	14		
	5	12		
	6	8		
	7	6		
	8	9		
	9	11		
A	3		MUX, DMUX channel select	
B	5			100kHz system clock
C	7			50kHz for #
D	4			25kHz counters
INHO	1		12.5kHz	
DMUX inhibit				
OSCI	34		internal clock	
SCCO	35		clock generator	
SCOI	36		master clock out 1.6MHz	
CLK	0	37	system clock in 1.6MHz	
	1	52		100kHz
	2	53		
	3	54		nc
	4	55		latch clock
XRES	33		reset pulse, active low	
MSEL	51		counter 12/13 bit select	
TST1	48		IC test	
TST2	49			
Vss	10		GND	
Vcc	42		power supply +5V	
VDD	26			
GAT	0	32	counter gate output low=counter tuning	
	1	31		
	2	30		
	3	30		
	4	29		
	5	28		
	6	25		
	7	26		



# TR-707/TR-727 MIDI IMPLEMENTATION

## 1. TRANSMITTED DATA

Status	Second	Third	Description
1001 xxxx	0xxx xxxx	0000 0000	Note ON xxxxxxxx - 15:51 51:51 60-74 (TR 727 only)
1002 xxxx	0xxx xxxx	0xxx xxxx	Note ON xxxxxxxx - 15:51 51:51 60-74 (TR 727 only)
1111 0010	0xxx xxxx	0xxx xxxx	Note Off xxxxxxxx - 15:51 51:51 60-74 (TR 727 only)
1112 0011	0xxx xxxx	0xxx xxxx	Note Off xxxxxxxx - 15:51 51:51 60-74 (TR 727 only)
1113 0000	0xxx xxxx	0xxx xxxx	Note Off xxxxxxxx - 15:51 51:51 60-74 (TR 727 only)
1114 1000	0xxx xxxx	0xxx xxxx	Note Off xxxxxxxx - 15:51 51:51 60-74 (TR 727 only)
1115 1001	0xxx xxxx	0xxx xxxx	Note Off xxxxxxxx - 15:51 51:51 60-74 (TR 727 only)
1116 1000	0xxx xxxx	0xxx xxxx	Note Off xxxxxxxx - 15:51 51:51 60-74 (TR 727 only)
1117 0000	0100 0001	0xxx xxxx	Tempo Mode xxxxxxxx - 15:51 51:51 60-74 (TR 727 only)

Notes: #1 Transmitted channel B can be changed to 1 - 16 from the front panel. When the panel is applied, the lowest channel B set error to the 1281 panel OFF remains unchanged.  
#2 When the message number is set.  
#3 When the track B is set.

track #	sssssss
1	sssssss
2	sssssss
3	sssssss
4	sssssss

Tempo Mode	Some Synchronized with
INTEREST	INTERNAL tempo clock
MIDI mode	received timing 1/16s
Disk mode	position edge of the Disk itself

#4 Note numbers are received as follows:  
Setting A: Normal  
Setting B: When the MIDI CH. BANK LAST STEP buttons are pressed while the "SHIFT" button is being pressed.

TR-727	Key Name	Setting A kkkkkkk	Setting B kkkkkkk
	No Range	58	59
	Low Range	61	36
	Mini M. Conga	62	38
	Open M. Conga	63	38
	Low Conga	64	41
	M. Timbale	65	41
	Low Timbale	66	48
	M. Agogo	67	37
	Low Agogo	68	56
	Cabasa	69	39
	Maracas	70	54
	Short Whistle	71	42
	Long Whistle	72	46
	Quilaja	73	49
	Star Chime	74	51

TR-707	Key Name	Setting A kkkkkkk	Setting B kkkkkkk
	Bass Drum 1	35	36
	Bass Drum 2	36	31
	Hi Hat	37	43
	Snare Drum 1	38	38
	Hand Stop	39	35
	Snare Drum 2	40	39
	Low Tom	41	41
	Closed Hi-Hat	42	41
	Mid Tom	43	41
	Open Hi-Hat	44	48
	High Tom	45	47
	Crash Cymbal	46	49
	Ride Cymbal	47	50
	Tamboourine	48	42
	Cowbell	49	46

## 2. RECOGNIZED RECEIVE DATA

Status	Second	Third	Description
1001 xxxx	0xxx xxxx	0xxx xxxx	Note ON xxxxxxxx - 15:51 51:51 60-74 (TR 727) #1 xxxxxxxx - 15:51 51:51 60-74 (TR 707) #2
1011 8xxx	0111 1100	0000 0000	Note OFF
1011 8xxx	0111 1101	0000 0000	Note OFF
1111 0010	0xxx xxxx	0xxx xxxx	Note Off xxxxxxxx - 15:51 51:51 60-74 (TR 707) #2
1112 0011	0xxx xxxx	0xxx xxxx	Note Off xxxxxxxx - 15:51 51:51 60-74 (TR 707) #2
1113 1000	0xxx xxxx	0xxx xxxx	Note Off xxxxxxxx - 15:51 51:51 60-74 (TR 707) #2
1114 1001	0xxx xxxx	0xxx xxxx	Note Off xxxxxxxx - 15:51 51:51 60-74 (TR 707) #2
1115 1000	0xxx xxxx	0xxx xxxx	Note Off xxxxxxxx - 15:51 51:51 60-74 (TR 707) #2
1116 0000	0100 0001	0100 0010	Tempo Mode xxxxxxxx - 15:51 51:51 60-74 (TR 707) #2

Notes: #1 Received channel B can be changed to 1 - 16 from the front panel. When the panel is applied, the lowest channel B set error to the 1281 panel OFF remains unchanged.  
#2 Recognized while in the Track Play mode. Any of the key numbers (35 - 58) was assigned to each instrument from panel selection, and will be kept assigned even after the panel is turned OFF. Received note numbers are assigned at the factory as follows:

TR-727	kkkkkkk	Instrument
	58	No Range
	59	Low Range
	60	Mini M. Conga
	61	Open M. Conga
	62	Low Conga
	63	M. Timbale
	64	Low Timbale
	65	M. Agogo
	66	Low Agogo
	67	Cabasa
	68	Maracas
	69	Short Whistle
	70	Long Whistle
	71	Quilaja
	72	Star Chime

TR-707	kkkkkkk	Instrument
	35	Bass Drum 1
	36	Bass Drum 2
	37	Hi Hat
	38	Snare Drum 1
	39	Hand Stop
	40	Snare Drum 2
	41,42	Low Tom
	42,43	Closed Hi-Hat
	44,45	Mid Tom
	46	Open Hi-Hat
	47,48	High Tom
	49	Crash Cymbal
	50	Ride Cymbal
	51	Tamboourine
	52	Cowbell

All the note OFF messages are ignored.  
#3 Recognized while the unit STOPS in the Track Play mode.  
#4 When the STC mode is ON.  
While in the Tape Interface mode, all MIDI messages are ignored.

## 3. HANDSHAKING COMMUNICATION

### 3.1 Message Type

3 1 1	Want to send a File (MSF)
Byte	Description
1 1111 0000	Exclusive status
1 0100 0001	Return ID #
1 0101 0000	Operation code
1 1111 0111	End of System Exclusive
3 1 2	Request a File (RDF)
Byte	Description
1 1111 0000	Exclusive status
1 0100 0001	Return ID #
1 0101 0000	Operation code
1 1111 0111	End of System Exclusive
3 1 3	Data (DAT)
Byte	Description
1 1111 0000	Exclusive status
1 0100 0001	Return ID #
1 0101 0010	Operation code
1 0000 0010	Format type
1 0100 nnnn	Block # (0 - 127)
1 0000 xxxx	0000 xxxx
0000 yyyy	512 data bytes (256 bytes of command)
0xxx zzzz	Check sum (for preceding 512 data bytes)
1 1111 0111	End of System Exclusive
3 1 4	Acknowledge (PAS)
Byte	Description
1 1111 0000	Exclusive status
1 0100 0001	Return ID #
1 0101 0011	Operation code
1 1111 0111	End of System Exclusive
3 1 5	Continue (CVS)
Byte	Description
1 1111 0000	Exclusive status
1 0100 0001	Return ID #
1 0101 0100	Operation code
1 1111 0111	End of System Exclusive
3 1 6	End of File (EOF)
Byte	Description
1 1111 0000	Exclusive status
1 0100 0001	Return ID #
1 0101 0011	Operation code
1 1111 0111	End of System Exclusive
3 1 7	Communication error (ERR)
Byte	Description
1 1111 0000	Exclusive status
1 0100 0001	Return ID #
1 0101 0011	Operation code
1 1111 0111	End of System Exclusive
3 1 8	Rejection (RJC)
Byte	Description
1 1111 0000	Exclusive status
1 0100 0001	Return ID #
1 0111 0010	Operation code
1 1111 0111	End of System Exclusive
3 2 1	When the RDF is recognized
1 RDF	Request a File (received)
1 DAT	Data (transmitted)
1 CAT	Continue (transmitted)
1 PAS	Acknowledge (received)
1 DAT	Data (16 times)
1 EOF	End of File (transmitted)
1 PAS	Acknowledge (received)
3 2 2	When the RDF is recognized
1 MSF	Want to send a file (received)
1 RDF	Request a file (transmitted)
1 DAT	Data (received)
1 CVS	Continue (received)
1 PAS	Acknowledge (transmitted)
1 DAT	Data (16 times)
1 EOF	End of file (received)
1 PAS	Acknowledge (transmitted)
3 2 3	When the VSF is received with error
1 VSF	Want to send a file (received)
1 RJC	Rejection (transmitted) (The sequence will abort then return to normal operation.)
3 2 4	When the EOF is received with error
1 RDF	Request a file (received)
1 RJC	Rejection (transmitted) (The sequence will abort then return to normal operation.)
3 2 5	When the ERR is recognized
DAT	Data (transmitted)
CAT	Continue (transmitted)
ERR	Communication error (received)
CAT	Continue (transmitted)
3 2 6	When DAT or others is received with errors
CAT	Data (received)
ERR	Communication error (transmitted)

The unit will expect to receive the previous DAT.